

# **Further Development of Aquaculture Techniques for the Production of WA Dhufish (*Glaucosoma hebraicum*)**

**FRDC Project 1999/322**

Incorporating

Development of Aquaculture Techniques  
for the Production of WA Dhufish  
(*Glaucosoma hebraicum*)  
FRDC Project 1996/308

**Dr Jennifer Cleary and Mr Greg Jenkins**

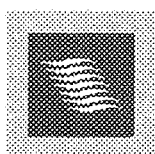

**WAMaritime**  
Training Centre  
Fremantle

CHALLENGER TAPE



Department of Fisheries  
Government of Western Australia



F I S H E R I E S  
R E S E A R C H &  
D E V E L O P M E N T  
C O R P O R A T I O N

## ***TITLE***

# ***Further Development of Aquaculture Techniques for the Production of WA Dhufish (*Glaucosoma hebraicum*) (FRDC Project 1999/322)***

## ***Incorporating***

# ***Development of Aquaculture Techniques for the Production of WA Dhufish (*Glaucosoma hebraicum*) (FRDC Project 1996/308)***

## ***Authors***

**Dr Jennifer Cleary and Mr Greg I Jenkins  
WA Maritime Training Centre, Fremantle  
Challenger TAFE  
1 Fleet Street, Fremantle, WA, 6160**

**February 2003**

## **Copyright**

© Fisheries Research and Development Corporation and the Aquaculture Development Unit, WA Maritime Training Centre, Challenger TAFE, Fremantle. 2003

This work is copyright. Except as permitted under the Copyright Act 1968 (Cth), no part of this publication may be reproduced by any process, electronic or otherwise, without the specific written permission of the copyright owners. Neither may information be stored electronically in any form whatsoever without such permission.

## **Disclaimer**

The authors do not warrant that the information in this book is free from errors or omissions. The authors do not accept any form of liability, be it contractual, tortious or otherwise, for the contents of this book or for any consequences arising from its use or any reliance placed upon it.

The importation, purchase and use of chemicals to treat animals (including fish) in Australia is controlled through the National Registration Authority for Agriculture and Veterinary Chemicals. Information on chemicals and dosage rates are provided in this document, based on published data, for specific life stages of individual species under laboratory conditions. The provision of the chemical and dose rate information in this document does not infer that the chemicals may be legally used for aquaculture in Australia. Some of the stated products in this text are unregistered, or not registered for the particular use. This should not be interpreted as a recommendation for use and the authors of this publication take no responsibility for losses should these chemicals or dosages be used in aquaculture. It is an offence to import and supply unregistered chemicals and the supply must be authorised by either a veterinary prescription or permit. Farmers should check the current registration status of chemicals with the National Registration Authority (02) 6272 5158, or <http://www.nra.gov.au>

**ISBN 0-9750577-0-7**

## Acknowledgments

All of the staff at the Aquaculture Development Unit of the Western Australian Maritime Training Centre, Challenger TAFE have contributed in various ways to the production of this hatchery manual. In particular we would like to thank Françoise Pironet for her commitment and substantial contribution in the early years of this research and Anthony Aris and Andrew Hughes for their contributions while serving as technicians on the dhufish culture project. Also special thanks to François Bosc for his time on the project and Tahryn Mackrill and Stuart Thrum for their many hours of enthusiastic voluntary assistance.

We are also grateful to all the staff at the ADU, including Ken Frankish (Hatchery Manager), Gavin Partridge (Biologist), Bruce Ginbey (Assistant Hatchery Manager), Sam Boarder, Dean Kennerly, Craig Poller, and Arron Strawbridge. Particular thanks also to our WA Department of Fisheries collaborators over the years of this project, Noel Morrissey, Brian Jones, Sagiv Kolkovski and Brett Glencross.

We also gratefully acknowledge the assistance and support given to us by the community. In particular we would like to thank Ron Lopresti, Ian McFarlane, Gary Ward, Bob Morris and Franz Van Der Poll for their assistance in catching broodstock.

We are grateful too for the contributions made by those from other research organisations: Fran Stephens, Shane Raidal and others from the School of Veterinary Studies, Murdoch University; Michael Payne, School of Environmental Biology, Curtin University; Alex Hesp, School of Biological Sciences and Biotechnology, Murdoch University and Julia Shand, Department of Zoology, University of Western Australia.

Funding for this project is provided by Challenger TAFE, Fisheries Research and Development Corporation and Fisheries Western Australia. We are grateful for their support.

## Table of Contents

<b>Acknowledgements</b> .....	<b>ii</b>
<b>List of Tables</b> .....	<b>v</b>
<b>List of Figures</b> .....	<b>vii</b>
<b>Chapter 1: Non-technical Summary</b> .....	<b>1</b>
<b>Chapter 2: Introduction</b> .....	<b>3</b>
2.1 Background .....	3
2.2 Potential of WA dhufish as an aquaculture species .....	4
2.3 Need .....	4
2.4 Benefits .....	5
2.5 Objectives .....	6
<b>Chapter 3: Biology of the Dhufish</b> .....	<b>7</b>
<b>Chapter 4: Broodstock</b> .....	<b>9</b>
4.1 Collection .....	9
4.2 Quarantine .....	11
4.3 Tank design.....	11
4.4 Husbandry.....	12
4.5 Feeding and nutrition.....	14
4.6 Handling.....	15
<b>Chapter 5: Reproduction</b> .....	<b>20</b>
5.1 Overview.....	20
5.2 Hormones.....	20
5.3 Egg production .....	22
5.4 Sperm collection, storage and quality assessment .....	25
5.5 Stripping and fertilisation.....	29
5.6 Rinsing and counting of eggs.....	30
5.7 Egg quality .....	31
5.8 Incubation, larval harvesting and counting .....	32
<b>Chapter 6: Larviculture</b> .....	<b>34</b>
6.1 Overview.....	34
6.2 Evolution of a suitable larval rearing system for dhufish .....	35
6.3 General larviculture principles.....	38
6.4 Summary of developmental stages .....	40
6.5 Weaning to a pellet.....	41
6.6 Harvest and survival estimates .....	41
<b>Chapter 7: Nursery and Grow-out</b> .....	<b>43</b>
7.1 Husbandry.....	43
7.2 Grading .....	43
7.3 Feeding and nutrition.....	44
7.4 Growth rates.....	45
<b>Chapter 8: Health and Disease Management</b> .....	<b>47</b>

8.1	Disease recognition .....	47
8.2	Disease diagnosis.....	48
8.3	Identified diseases and their treatments .....	49
8.4	FRDC Final Report:98/328 Non-Technical Summary .....	54
<b>Chapter 9: References.....</b>		<b>55</b>
<b>Appendices .....</b>		<b>A1</b>
Appendix A:	Decompression sickness in Western Australian dhufish ( <i>Glaucosoma hebraicum</i> ).....	A1
Appendix B:	Suitability of bore salt-water and ocean water for rearing dhufish.....	A30
Appendix C:	Specifications for vitamin and mineral premix.....	A32
Appendix D:	Recipe for moist pellet.....	A33
Appendix E:	Technique for making and administering an LHRHa slow-release cholesterol pellet.....	A34
Appendix F:	Stimulating in-tank spawning in acclimated dhufish .....	A37
Appendix G:	The response of acclimated female dhufish to implant with an LHRHa slow-release pellet.....	A41
Appendix H:	Stimulating ovulation from dhufish caught from the wild during the spawning season .....	A45
Appendix I:	Determining the window of post-ovulatory viability .....	A54
Appendix J:	The effect of LHRHa slow-release pellet on acclimated males.....	A57
Appendix K:	Collection of sperm from different sources.....	A60
Appendix L:	Cryopreservation of dhufish spermatozoa .....	A62
Appendix M:	Hormone-induced spawning and development of artificially reared larvae of the West Australian dhufish, <i>Glaucosoma hebraicum</i> .....	A87
Appendix N:	WA Dhufish Larval Rearing - 1999/2000 End of Year Report.....	A97
Appendix O:	Cultured copepods as food for West Australian dhufish ( <i>Glaucosoma hebraicum</i> ) larvae .....	A120
Appendix P:	Developing a weaning technique for dhufish larvae .....	A147
Appendix Q:	Evaluation of feed ingredient utilisation and native tissue composition as a precursor to diet development for the West Australian dhufish ( <i>Glaucosoma hebraicum</i> ) .....	A156
Appendix R:	Treatments for ectoparasites and diseases in captive Western Australian dhufish .....	A171
Appendix S:	Intellectual Property .....	A182
Appendix T:	Staff involvement in this FRDC project .....	A182

## List of Tables

Table 1:	Summary of larviculture trials for dhufish at the ADU .....	37
Table A1:	Solubility coefficients for nitrogen gas in biological fluids at 37°C .....	A7
Table A2:	Mean damage scores and standard errors for gross bubble formation in WA dhufish upon capture from 2 depth categories .....	A13
Table A3:	Mean damage scores and standard errors for gross haemorrhaging in WA dhufish upon capture from two depth categories .....	A13
Table A4:	Mean swimbladder inflation scores and presence of exophthalmia in WA dhufish upon capture from two depth categories .....	A14
Table A5:	Mean damage scores + SE for heart histopathology in WA dhufish upon capture from two depth categories .....	A14
Table A6:	Mean damage scores + SE for liver histopathology in WA dhufish upon capture from two depth categories .....	A15
Table A7:	Mean damage scores + SE for kidney histopathology in WA dhufish upon capture from two depth categories .....	A16
Table A8:	Mean damage scores + SE for spleen histopathology in WA dhufish upon capture from two depth categories .....	A16
Table A9:	Specifications for vitamin/mineral premix .....	A32
Table A10:	Ingredients for moist pellet .....	A33
Table A11:	Schedule for oral administration of LHRHa to captive female dhufish .....	A38
Table A12:	Length-weight-dose conversion used at sea to determine correct hormone dose for injection .....	A46
Table A13:	Capture rate of sexually mature dhufish caught from the wild in shallow water .....	A48
Table A14:	The initial oocyte diameter, number of ovulations, and the number of viable eggs from individual female dhufish caught from the wild and treated with hormones at capture .....	A49
Table A15:	Composition of the two diluents used for diluting semen samples prior to cryopreservation .....	A67

Table A16: Composition of the marine teleost ringers used in both diluents .....	A68
Table A17: Summary of the varying techniques for collecting, preparing, cryopreserving and thawing semen samples for dhufish, black bream and snapper trials .....	A72
Table A18: The range of post-freeze activities for dhufish trial 1 .....	A74
Table A19: Hormone treatments in male and female <i>Glaucosoma hebraicum</i> (Table 1, Pironet and Neira, 1998) .....	A88
Table A20: Diameter ( $\mu\text{m}$ ) of eggs of <i>Glaucosoma hebraicum</i> spawned naturally and after hormone treatment (Table 2, Pironet and Neira, 1998) .....	A89
Table A21: Body Length, age and body proportions of larval stages of <i>Glaucosoma hebraicum</i> reared in the laboratory (Table 3, Pironet and Neira, 1998).....	A89
Table A22: Final (day 12) densities of nauplii, copepodids and adult copepods in <i>Nannochloropsis</i> greenwater treatments (mean $\pm$ sd) (Table 2-1.).....	A127
Table A23: Production outputs from three intensive copepod cultures operated in 1000 l tanks at ADU (Table 6-1) .....	A141
Table A24: Composition of microbound diet used in experiment 1 and 2 .....	A150
Table A25: Formulation, proximate and digestibility specifications of the basal diet .....	A167
Table A26: Proximate composition of the ingredients used in the test diets .....	A168
Table A27: Digestible nutrient contributions of specific ingredients .....	A169
Table A28: Digestible nutrient contributions from compounded ingredient diets .....	A169
Table A29: Amino acid compositions of native dhufish flesh .....	A170
Table A30: Treatments used, their duration and survival rate of dhufish in captivity at Fremantle .....	A174

## List of Figures

Figure 1:	Dhufish from the captive breeding program at the ADU .....	7
Figure 2:	Mean monthly gonadosomatic indices for female and male dhufish caught in offshore waters between Geraldton and Perth between May 1996 and April 1998.....	8
Figure 3:	Diagram showing location of swimbladder and point of insertion to deflate the swimbladder .....	10
Figure 4:	Dhufish broodstock being implanted with a PIT tag using a commercial applicator.....	11
Figure 5:	Floating egg collector.....	12
Figure 6:	Crowding dhufish broodstock using a circular floating crowd.....	15
Figure 7:	Dhufish in a foam restraint .....	18
Figure 8:	Cradle for weighing and measuring dhufish.....	19
Figure 9:	The action of LHRHa and hCG on the reproduction in marine fish .....	21
Figure 10:	Stripping male dhufish.....	26
Figure 11:	Stripping female dhufish.....	29
Figure 12:	Egg counting cone .....	30
Figure 13:	Permanent siphon.....	30
Figure 14:	Floating incubation cone .....	32
Figure 15:	5000L larval rearing tank.....	38
Figure 16:	Surface skimmer.....	39
Figure 17:	Dhufish eggs undergoing organogenesis.....	40
Figure 18:	Newly hatched dhufish larvae.....	40
Figure 19:	Fully metamorphosed juvenile dhufish.....	40
Figure 20:	Juvenile dhufish being stocked onto a new tank following grading .....	43



Figure 21: Growth of hatchery-reared dhufish .....	45
Figure A1: The effects on the volume of a balloon as pressure increases with depth (according to Boyle's Law).....	A5
Figure A2: To maintain a constant volume in the balloon, gas has to be pumped into it as pressure increases with dhufish .....	A5
Figure A3: The Westralian dhufish .....	A20
Figure A4: The formation of bubbles in the residue blood in the gut cavity .....	A20
Figure A5: Shallow water fish with minor haemorrhage in the liver.....	A21
Figure A6: Deep water fish with moderate to severe haemorrhage in liver .....	A21
Figure A7: Slight haemorrhaging in the capillaries on the inside of the swim bladder of a shallow water fish .....	A22
Figure A8: Severe haemorrhaging in the capillaries on the inside of the swim bladder of a deep water fish .....	A22
Figure A9: Heavy inflation of the swim bladder in a shallow water fish .....	A23
Figure A10: Exophthalmia (protrusion of the eyes) in a deep water fish .....	A23
Figure A11: (4x) Large bubbles in the tissue of the heart of a deep water fish.....	A24
Figure A12: (10x) Heavy clotting in the heart tissue of a deep water fish .....	A24
Figure A13: Bubbles and clotting occluding a blood vessel in the liver of a deep water fish .....	A25
Figure A14: Large bubbles in the pancreatic tissue (purple tissue) surrounding a blood vessel in the liver.....	A25
Figure A15: (4x) Severe haemorrhaging in the liver of a shallow water fish.....	A26
Figure A16: (4x) Empty blood vessels with large spaces between the vessel and the liver.....	A26
Figure A17: (10x) Haemorrhaging with large bubble formation in the tissue of the kidney .....	A27
Figure A18: (10x) Heavy clotting in the spleen of a deep water fish (pink area in centre with white blood cell accumulation .....	A27

Figure A19: Implanting a slow-release cholesterol pellet into a sexually mature female held in a foam restraint. ....	A36
Figure A20: Change in mean oocyte diameter with time in acclimated female dhufish following treatment with an LHRHa slow-release cholesterol pellet.....	A42
Figure A21: The number, percent viability, percent fertilisation and percent hatch of eggs stripped from acclimated female dhufish following treatment with an LHRHa pellet slow release cholesterol pellet. ....	A43
Figure A22: Change in oocyte diameter with time from treatment of individual female dhufish caught from the wild and treated at capture with hormones.....	A50
Figure A23: The mean number, percent viability, percent fertilisation, and percent hatch of eggs stripped from female dhufish caught from the wild and treated with hormones.....	A51
Figure A24: The percentage of a) round, clear and buoyant eggs and b) percent fertilisation of eggs stripped from ovulating dhufish at 0, 3, 6, and 9h after ovulation. ....	A55
Figure A25: The proportion of dhufish males spermiating 0, 72 and 168h following treatment with a slow release cholesterol pellet. ....	A57
Figure A26: Volume of sperm stripped from dhufish males at 0, 72 and 168h following treatment with a slow release cholesterol pellet. ....	A58
Figure A27: Activity of sperm stripped from dhufish males at 0, 72 and 168h following treatment with a slow release cholesterol pellet. ....	A58
Figure A28: Activity of sperm collected from a variety of sources.....	A61
Figure A29: Apparatus for a slow freeze in liquid nitrogen vapour.....	A69
Figure A30: Apparatus for a rapid freeze in liquid nitrogen vapour.....	A70
Figure A31: Thawing of vials and straws for dhufish trials 2 and 3, all black bream trials, and snapper trial.....	A71
Figure A32: Comparison of means for initial, pre-freeze and post-freeze activities for dhufish, black bream and snapper.....	A75

Figure A33: Mean initial, pre-freeze and post-freeze activities of sperm cells for each treatment for dhufish trial 1 .....	A76
Figure A34: Mean initial, pre-freeze and post-freeze activities of the sperm cells for each treatment for dhufish trials 2 and 3.....	A77
Figure A35: Mean initial, pre-freeze and post-freeze activities of the sperm cells for each treatment for black bream trial .....	A79
Figure A36: Mean initial, pre-freeze and post-freeze activities of the sperm cells for each treatment for snapper trial.....	A80
Figure A37: Body length v. age of reared larvae <i>Glaucosoma hebraicum</i> (Fig. 1. Pironet and Neira, 1998) .....	A89
Figure A38: Larvae of <i>Glaucosoma hebraicum</i> reared in the laboratory (Fig. 2, Pironet and Neira, 1998) .....	A92
Figure A39: 31.0mm BL reared juveniles of <i>Glaucosoma hebraicum</i> (Fig 3, Pironet and Neira, 1998) .....	A94
Figure A40: Nauplius density in greenwater tanks comprising <i>Dunaliella</i> (A) and <i>Nannochloropsis</i> (B). Adult copepods were stocked at two different densities, 100/l and 200/l. Data represented as mean $\pm$ sd (Fig 2-1A and B).....	A126
Figure A41: Growth (A) and survival (B) of larval dhufish in greenwater systems with different live food treatments. (Fig. 3.1) .....	A129
Figure A42: Growth of dhufish reared in two 5000 l greenwater larviculture vessels (Fig 4-1).....	A132
Figure A43: Changes in the proportion of different prey in the gut of larval dhufish over time, with separate data for batch DF00-04 (A) and batch DF00-05 (B). (Fig 4-2) .....	A134
Figure A44: Prey densities in greenwater larviculture tanks. Separate data for DF00-04 (A) and DF00-05 (B) are provided (Fig 4-3).....	A135
Figure A45: Schematic diagram of a 1000 l copepod culture system (Fig. 6-1) .....	A140
Figure A46: Survival of adult <i>G. imparipes</i> fed excess diets of T-Iso and a heterotrophic haptophyte collected from 1000 l T-Iso cultures which it had invaded. (Fig 6-2.) .....	A141

Figure A47: Cumulative maturation (logit transformed) over time of female copepods fed *Heterocapsa*, T-Iso and a combination of both at 20°C (Fig 7-1).....A144

Figure A48: Survival of dhufish larvae during weaning experiment 1 and 2.....A151

Figure A49: Wet weight of dhufish larvae at 20 and 35 days during weaning experiment 1 and 2 .....A152

Figure A50: Strike rate of dhufish larvae on various trial weaning diets.....A153

## Chapter 1: NON-TECHNICAL SUMMARY

**1999/322 Further Development of Aquaculture Techniques for the Production of WA Dhufish (*Glaucosoma hebraicum*)**

**1996/308 Development of Aquaculture Techniques for the Production of WA Dhufish (*Glaucosoma hebraicum*)**

**PRINCIPAL INVESTIGATOR:** Dr J Cleary  
**ADDRESS:** WA Maritime Training Centre - Fremantle  
Challenger TAFE  
1 Fleet Street, Fremantle, WA, 6160  
Telephone: 08 9239 8030 Fax: 08 9239 8081

### **OBJECTIVES:**

#### **1996/308**

1. Reliable production of fertilised eggs
2. Successful production of larvae
3. Successful production of fingerlings
4. Development of production procedures for commercial production of fingerlings
5. Development of pelletised grow-out diet
6. Production of market-sized fish in one year
7. Increased knowledge of the species

#### **1999/322**

1. To increase knowledge of the species, in particular reproduction, larval rearing and weaning.
2. To improve techniques for hormonal induction of ovulation
3. To achieve in-tank spawning of F1 fish
4. To achieve out-of-season spawning of F1 fish
5. To assess capacity of cryopreserved sperm to fertilise eggs
6. To reliably produce fertilised eggs
7. To refine larval rearing techniques
8. To successfully wean larvae
9. To develop a suitable grow-out diet
10. To produce F2 fish
11. To produce a hatchery manual on dhufish culture

## Non-Technical Summary

One of the tasks carried out by the Aquaculture Development Unit (ADU) of Challenger TAFE is to investigate the potential for culture of a number of marine aquaculture species of interest to the pre-emergent industry in Western Australia. As this industry struggles to emerge in WA, a number of small companies have attempted to culture a range of marine fish species, including the WA dhufish, generally with poor results. Numerous other companies and individuals constantly enquire about 'the best fish to grow' and the WA dhufish has historically always been number one on this list in Western Australia.

As a result of the previous, unsuccessful culture attempts for this species by industry, and the numerous and on-going further enquiries, the ADU undertook a preliminary, one year investigation with the support of the FRDC (Project 95-095). Within this preliminary, 12 month project, ADU staff captured and maintained broodstock in the Fremantle hatchery, successfully obtained 31,000 fertilised eggs of the captive fish through hormonal inducement and stripping, and cultured 24 fish to 6 months of age (see FRDC Final Report 95-095). This initial encouraging result led to the two further FRDC supported programs reported here.

In the subsequent projects reported on here, many of the objectives were achieved. However, there were no easy methods for the culture of the fish and every step of the way was difficult. The broodstock, including first generation fish, would not spawn naturally in captivity and continued hormonal inducement and stripping of eggs were required. The larvae were difficult to grow and required feeding with copepods in addition to the standard live feeds for marine fish species of rotifers and *Artemia*. Fish health concerns were always evident, with the species susceptible to exophthalmia (pop-eye), nutritional deficiencies and a range of other ailments. Growth rates were variable, suspected to be due to the health concerns.

In 1997, as a result of the ongoing concerns for the health problems with the WA dhufish, the ADU approached Dr Shane Raidal of the Murdoch University Division of Veterinary and Biomedical Sciences for fish health assistance. Murdoch University was subsequently funded by the FRDC in 1998 to investigate the health problems of the WA dhufish (FRDC Project 98-328). Dr Fran Stephens of Murdoch University undertook this work.

The WA dhufish health project identified numerous parasites and disease causing organisms for the species and also identified treatments (See FRDC Final Report 98-328). However, during the course of the Murdoch University investigations, it was determined that the WA dhufish has but a single type of haemoglobin in their blood, whereas most fish tested have 4 or five different types of haemoglobin. Multiple haemoglobin types is believed to allow fish species to be flexible in their adaptation to their environment, accommodating various environmental conditions such as temperatures and low oxygen concentrations.

The WA dhufish lives in a region where the environment is relatively constant, and so has not required to be environmentally 'flexible' Aquaculture species however, do require flexibility, as they require to be cultured at high densities and under varying conditions. The single haemoglobin of the WA dhufish may be part of the reason why the culture of this species is so difficult.

This final report details the findings of over 5 years of aquaculture research on the WA dhufish. The authors of this report consider that the WA dhufish is not currently, or will be in the short to medium future, a viable species for commercial aquaculture due to the wide range of difficulties in their culture. Despite this result, the authors believe that the results of this project are of great benefit to the emerging WA industry. In addition to the documentation of a range of procedures and trials of great interest to the marine aquaculturist, this report will save the industry considerable time and funds as they seek 'the right fish to grow'.

The results of FRDC Projects 96-302 and 1999-322 are set out in the ADU 'Hatchery Manual' style for easy reading and comprehension. Numerous scientific publications are also available for the further perusal of scientists.

**Keywords:** dhufish, *Glaucosoma hebraicum*, aquaculture, health.

## Chapter 2: Introduction

### 2.1 Background

The Western Australian Maritime Training Centre (WAMTC) is a Fremantle campus of Challenger TAFE, which is managed by the Western Australian Department of Training (WADT). During 1992, the Chief Executive Officer of WADT began implementing a policy of associating TAFE colleges closer to industry. This included the provision of facilities to encourage industry groups to participate in applied research projects and joint ventures. In 1993 funding was allocated to formally establish an Aquaculture Development Unit (ADU) at WAMTC. The principal objective of the ADU is to assist with the development of the marine aquaculture industry in Western Australia.

The emphasis of the ADU to date has been on the development of cost-effective production techniques suitable for marine finfish culture. Target species have included snapper (*Pagrus auratus*), black bream (*Acanthopagrus butcheri*), WA dhufish (*Glaucosoma hebraicum*), estuary cod (*Epinephelus coioides*), King George whiting (*Sillaginodes punctata*) and the yellow-tail kingfish (*Seriola lalandi*). In addition, investigations are being carried out to develop aquaculture techniques for various species of molluscs, particularly Roe's abalone (*Haliotis roei*) and staircase abalone (*Haliotis scalaris*).

The ADU have been conducting research into the development of aquaculture techniques for dhufish since 1995. This research has been funded by Challenger TAFE and the Fisheries Research and Development Corporation (FRDC) with supplementary funding provided by Fisheries WA and Recfishwest. There have been three successive FRDC projects on the culture of dhufish: Project 95/095 (1 year); Project 96/302 (3 years) and 1999/322 (1 year). This document reports on Projects 96/302 and 1999/322. There are five main foci for research to develop culture techniques for WA dhufish: general husbandry, reproduction, larval rearing and weaning, grow-out (including nutrition), and health.

Other related projects include:

- Visual development in the WA dhufish (FRDC Project 98/329)
- Intensive cultivation of a calanoid copepod for live food in fish culture (FRDC Project 96/398)
- Use of cultured copepods as food for WA dhufish (Aquaculture Development Council of WA)
- Health problems in Western Australian dhufish (FRDC Project 98/328).
- Determination of the biological parameters required for managing the fishery of Western Australian Dhufish (FRDC Project 96/103)

## *2.2 Potential of WA dhufish as an aquaculture species*

Dhufish is a premium quality table fish, with a firm white flesh. It is highly priced compared with other local species, with a beachfront price of around \$10.00 per kg for whole fish (1999). While there is a firmly established local market, there is also potential for expansion of new markets as fish with similar flesh quality are in high demand in both domestic and export markets. These factors, combined with limitations in supply indicate enormous potential for the culture of dhufish (Barnetson unpub). At the ADU, initial investigations into the possibility of supplying juvenile dhufish to the aquarium trade has also been explored, with a small number of dhufish juveniles being sold for \$50.00 per fish. These initial sales were well received and prompted further enquiries by interested aquarists.

Considerable advances have been made in the culture of dhufish at the ADU. The number of juveniles produced increased from 24 to 2000 in 5 years of research (at 100 days post hatch). This represents an increase of more than 80 times. This reflects improvements in both the number of fertilised eggs produced and the survival of larvae and juveniles. Satisfactory techniques have been developed for all the crucial stages in their life history. Dhufish culture, however, is still difficult and there are many areas that require further research prior to industry development, in particular egg production, larval rearing, nutrition and health.

## *2.3 Need*

The WA dhufish is a premium quality finfish with attributes suitable for aquaculture. Continued research into developing culture techniques for high value finfish in general is necessary to: 1) provide a high value species to the aquaculture industry in WA; 2) alleviate fishing pressure on the wild populations of marine fish by meeting demand with farmed fish and to enable better management of the fishery.

- 1) There are currently several companies committed to farming marine finfish in WA. The species available for culture (snapper and black bream) have low to medium level prospects for price and markets. An urgent need exists for the development of technology suitable to culture a high priced, market driven species to support the endeavours of this fledgling industry. Although it is technically possible to produce WA dhufish, the current cost of dhufish culture would be significantly higher to that of other marine finfish species.

There are concerns regarding the use of seacages for the grow-out phase of marine finfish farming along the WA coastline. These concerns include the limited number of potential protected sea-cage sites along the high-energy coastline of WA and the perceived environmental impact of seacages, including damage to seagrass beds and eutrophication. These problems can be minimised by the establishment of land based



facilities, as these facilities can clean up effluent water prior to discharge, and it is not necessary for them to be located in protected sites. Land based grow-out facilities are however, more expensive to establish than sea-based grow-out cages and the greater potential margins offered by a high value species will be very important. It is possible that techniques developed for the WA dhufish (a deep water reef dwelling fish) will be transferable to other highly valued species occupying a similar niche.

- 2) Fisheries WA have recently identified dhufish as a species "at risk" and requiring close monitoring. The development of culture technology for WA dhufish may enable the government, at some time in the future, to facilitate the restocking of this valuable species into their natural habitat.

Little is known about the biology and ecology of dhufish in the wild. The lack of information available has meant that historic Fisheries WA management strategies (bag and size limits) have been developed in the absence of rigorous data (Sudmeyer *et al*, 1990). More information about the life history of dhufish is clearly important. Information gained during the culture project has already been used by fisheries researchers and managers. For example, prior to the successful culturing of dhufish larvae at the ADU, dhufish larvae had never before been observed. In addition, research conducted as an adjunct to this project (funded by the Recreational Fishing Advisory Committee) indicated that dhufish caught in the depths of over 20 metres are unlikely to survive due to barotrauma related injuries. If substantiated with further research, this has major implications for fisheries management in that current practice is to impose a size limit and return undersized fish to the sea. Therefore the research from this project has broader ramifications than just for the aquaculture industry.

## 2.4 Benefits

- The Western Australian marine finfish farming industry has benefited from the development of culture technology for the WA Dhufish. The authors of this report consider that the WA dhufish is not currently, or will be in the short to medium future, a viable species for commercial aquaculture due to the wide range of difficulties in their culture. Despite this opinion, the authors believe that the results of this project are of great benefit to the emerging WA industry. People constantly enquire about 'the best fish to grow' in WA and the WA dhufish has historically always been number one on this list. In addition to the documentation of a range of procedures and trials of great interest to the marine aquaculturist, this project and subsequent report will save the industry considerable time and funds as they seek 'the right fish to grow' (ie other than the WA dhufish).
- The management of the wild WA Dhufish fishery has benefited from this research.

- The recreational fishing community (and the general public) have also benefited due to the flow on effects of better fisheries management strategies and the increased focus of wild fisheries research scientists and programs onto this species as a consequence of this and related projects.

## 2.5 Objectives

### Part A. Project No. 96/308

- A1. Reliable production of fertilised eggs (in excess of 100,000 eggs on five occasions)
- A2. Successful production of larvae (minimum of 500,000)
- A3. Successful production of fingerlings (minimum of 10,000)
- A4. Development and documentation of procedures for commercial production of fingerlings
- A5. Development of pelletised grow-out diet
- A6. Production of market size fish in one year
- A7. Increased knowledge of the species

### Part B. Project No. 1999/322

- B1. To increase knowledge of the species, in particular reproduction, larval rearing and weaning
- B2. To improve techniques for hormonal induction of ovulation
- B3. To achieve in-tank spawning of F1 fish
- B4. To achieve out-of-season spawning of F1 fish
- B5. To assess capacity of cryopreserved sperm to fertilise eggs
- B6. To reliably produce fertilised eggs
- B7. To refine larval rearing techniques
- B8. To successfully wean larvae
- B9. To develop a suitable grow-out diet
- B10. To produce F2 fish
- B11. To produce a hatchery manual on dhufish culture

Objectives listed under Part B are for a three-year project, of which only one year was completed. Although these objectives (with the exception of B3, B4, B10) were addressed to some degree, the thoroughness of their treatment was limited by the short life-span of the project.

### Chapter 3: Biology of the dhufish

*Glaucosoma hebraicum* or West Australian dhufish belong to the family Glaucosomatidae. Their distribution is limited to the south-west coast of Australia, from the Recherche Archipelago in the south to Shark Bay in the North (Hutchins and Swainston, 1986; McKay, 1997).

Little is known of the biology and ecology of the dhufish. Some studies have been conducted on adult dhufish in the wild, however, the early life stages (larvae and juveniles) have received little attention. In fact, until dhufish larvae were first successfully reared at the ADU, they had never been identified in the wild. Consequently the location of nursery grounds is unknown, as is the natural diet, and growth rates of larvae and juveniles.

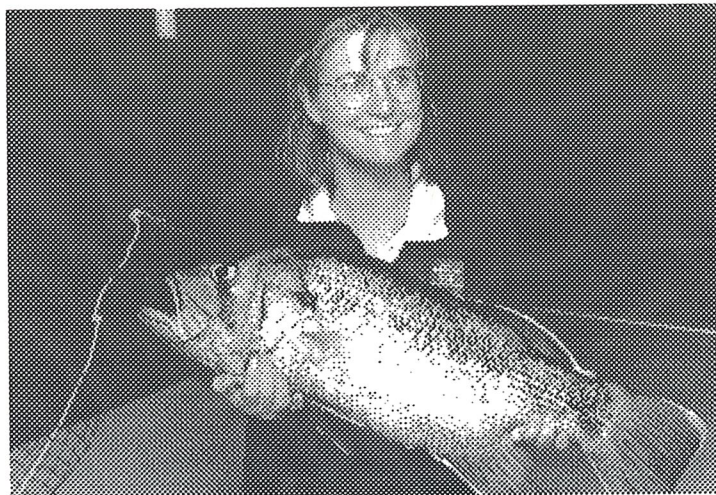

**Figure 1: Dhufish from the captive breeding program at the ADU.**

In the wild, adult dhufish grow to a maximum total length of 1200 mm and a maximum weight of 26 kg (Hutchins and Swainston, 1986). Adult dhufish feed predominantly on reef dwelling fish, including wrasse, leatherjacket, eels and mullet. Crustaceans (rock lobster, prawns, crabs) and molluscs (octopus, squid, cuttlefish) also contribute to the diet (reviewed in McKay, 1997). They can be found in waters up to 200m in depth, close to submerged reefs or rough bottom and frequent caves and overhanging ledges (McKay, 1997).

Dhufish are multiple spawners (ie they spawn more than once during the spawning season). In the wild, they spawn between December and April, with a peak in spawning activity in late January or early February (Hesp and Potter, 2000). As the spawning season approaches, heralded by increased water temperature and day-length, the ovary and testes increase in size. The weight of the gonad as a proportion of its body weight is called the gonadosomatic

index (GSI), and is used to determine the spawning season for fish in the wild. The GSI for female dhufish increases from 0.8 in July to 2.8 in January (Fig 2). In males the changes are less dramatic; the GSI increases from 0.08 in July to 0.20 in January. In the wild, the majority of female and male dhufish first reach sexual maturity at around 250-299 mm and 250 to 400 mm in length respectively (Hesp and Potter, 2000). Male dhufish can be distinguished from female dhufish, once more than approximately 2kg in weight. In male dhufish the 4<sup>th</sup> soft dorsal ray on the dorsal fin is extended into a white filament (McKay, 1997). In the female, the 4<sup>th</sup> ray does not protrude, but is flush with the other rays.

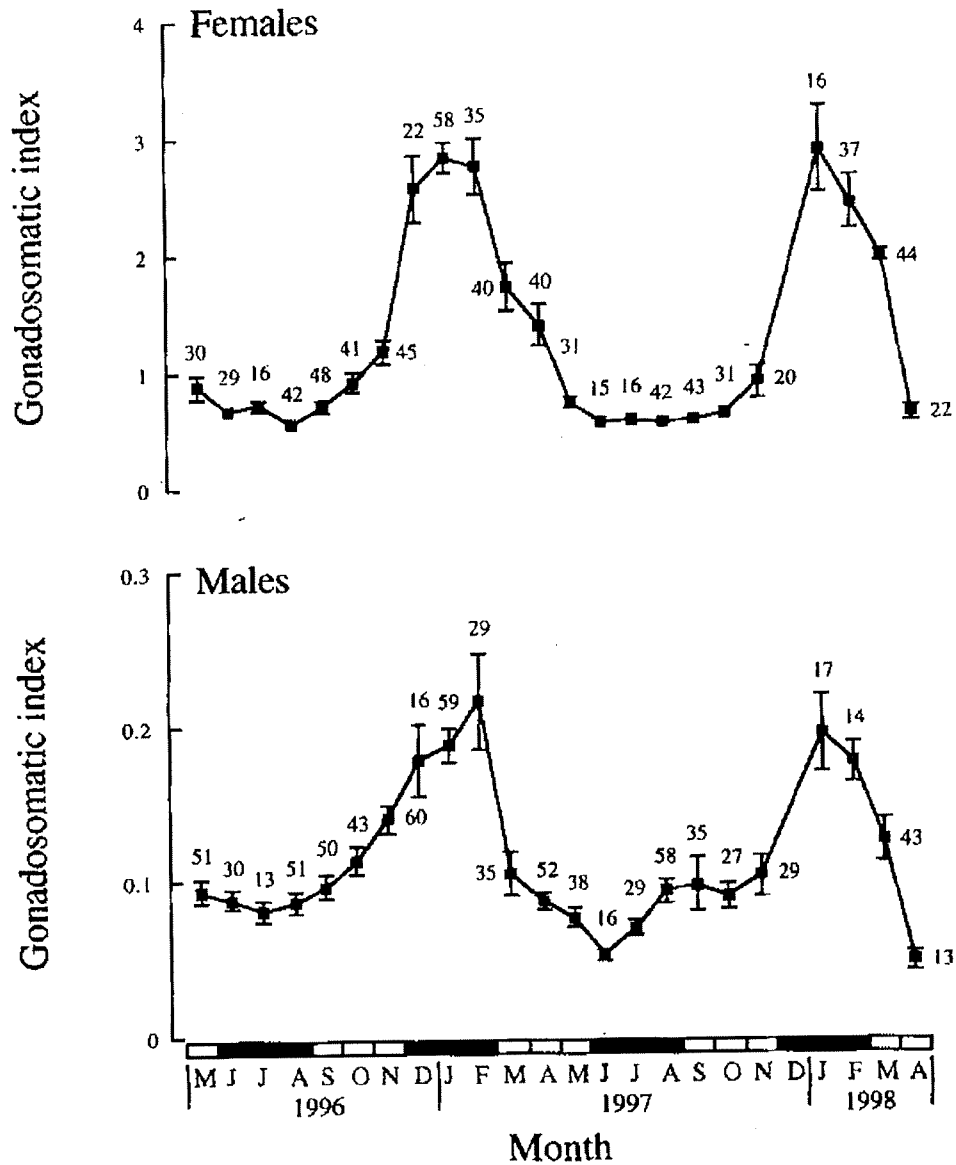

Figure 2: Mean monthly gonadosomatic indices +1SE for female and male dhufish caught in offshore waters between Geraldton and Perth between May 1996 and April 1998. Numbers of fish in each month are shown above each mean. (from Hesp and Potter, 2000).

## Chapter 4: Broodstock

### 4.1 Collection

The preferred method for broodstock capture is by handline. Droplines and traps have also been trialed. Although droplines can be a highly effective means of catching dhufish, the stress of capture is higher than by a simple handline, due to the increased length of time the fish may be on the hook before landing. Trials using traps were conducted in cooperation with Fisheries WA. These however proved unsuccessful partly because dhufish seldom enter a trap, but also because trap-captured dhufish sustained a high degree of damage rendering them unsuitable as broodstock. The degree of damage was greater than that sustained by other species in the same trap.

Once captured, the fish should be landed directly into a tub filled with seawater. A 250 L insulated plastic tank, with a well-secured lid, is suitable for holding up to five 2 to 5kg dhufish. Once the fish is in the tub, the hook can be gently removed using long nosed pliers. If the hook is difficult to remove (ie in the gill rakers or gut), the line should be cut. The fish will normally release the hook within a few weeks of capture. Surgical gloves or other smooth gloves should always be worn when handling dhufish, in order to prevent loss of scales and damage to the mucous layer.

All bony fish have one of two types of swimbladders. Some species, known as physostomes have a pneumatic duct connecting the swimbladder to the gut. When a fish changes depth, the air in the swim bladder expands due to the reduced external pressure. During pressure change, physostomes reduce pressure by expelling gas into the gut via the pneumatic duct. Other fish, including dhufish are physoclists and lack a pneumatic duct. Their swim bladder is enclosed, but is serviced by a capillary bed, which allows gas to move to and from the swimbladder. When pressure change is gradual (eg when the fish voluntarily moves to shallow water), excess gas can be removed through the blood stream. During rapid pressure change (eg during capture by line), however, the excess gas cannot be cleared rapidly enough, resulting in supersaturation of the blood (leading to decompression sickness) and rupture of the swimbladder due to excess pressure (Appendix A).

The swimbladder of the dhufish, therefore, must be vented immediately after capture. Swim bladder deflation is performed by inserting a large bore (16 or 18 gauge) sterile hypodermic needle through the body wall into the swimbladder. The simplest and most effective place to insert the needle is 5 to 7 scales toward the tail from the tip of the operculum (just below the lateral line; Fig 3). If the needle is correctly located, air bubbles out and the needle is removed once the pressure in the swim bladder is dissipated.

A study, funded by the Recreational Fishing Advisory Committee and conducted by the ADU, found that dhufish caught from depths of greater than 20m sustain a higher incidence of liver, heart and swim bladder haemorrhage, exophthalmia, and swim bladder rupture compared with fish caught from shallower waters (Appendix A). Severely affected fish normally die within hours of capture. Dhufish broodstock are caught in shallow water to prevent this occurrence. A study has subsequently commenced by Fisheries WA to investigate the effects of capture depth on long term survival. However, at the ADU, capture is limited to depths of less than 25m to maximise survival. At the ADU, most dhufish broodstock were caught during the winter months as they are generally easier to catch in shallow waters at this time. During the spawning season (Summer/Autumn) the majority of dhufish appear to migrate to deeper waters, resulting in additional time and therefore cost to capture them from shallow waters. If sexually mature dhufish are being sought, the best time to catch these fish is early in the spawning season (ie mid-December to mid January in Fremantle).

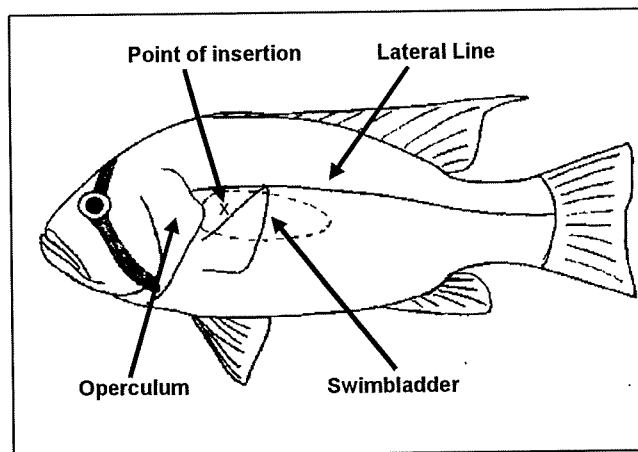

**Figure 3: Diagram showing location of and point of insertion for deflation of the swimbladder**

While at sea, the fish are transported in the 250 L tub described above. A well-secured lid must be used to prevent the fish jumping out, and to help retain water in the tub. When the boat is under-way, it is essential that the tub be kept completely full of water. This reduces water movement and so minimises the fish hitting the sides of the tank due to wave motion. Water should be exchanged regularly, either by bucket, or a submersible pump. A constant supply of oxygen should also be applied.

The fish can be transferred from the boat to road transport in a suitably sized covered tub, containing water. Alternatively a smooth vinyl sling, closed at both ends may also be used over short distances. Smooth plastic gloves are always worn, and care taken, as fish are stressed and flighty at this time. Road transport to the hatchery facility should be in a suitably sized tank (250L or greater depending on the size and number of fish and the distance to be transported) with a well secured lid. A generator may be used to run a blower to aerate the water. Other options are to use oxygen from bottles, or a battery-operated aerator. If the fish

are to be transported long distances, it may be necessary to change the water during the journey to remove toxic waste products and maintain a suitable temperature. This can be done using a submersible pump to pump directly from the ocean. Care should be taken to ensure that the incoming water is clean and free of sediment. Using these methods, survival of broodstock from capture to the hatchery was greater than 95 %.

## 4.2 Quarantine

Fish caught from the wild are normally heavily infested with a wide range of ectoparasites, including isopods, copepods and gill fluke (Pironet and Jones, 2000; Appendix P). For this reason fish are placed in 4000L quarantine tanks, when they first arrive at the hatchery. The tanks are fitted with well-secured nets to prevent jumping. The fish appear calmer at low light levels so black plastic is used to cover up to 90% of the tank surface to keep the fish in the dark. This preference for low light conditions immediately after capture is likely due to the low light conditions in the fish's natural habitat; ie rocky reefs and caves (McKay 1997). The quarantine tanks are located in an area that is remote from other stocks of dhufish. Two freshwater baths 2 weeks apart are then applied to eradicate the parasites and prevent infection of established broodstock (see Chapter 8). After the period of quarantine the fish are anaesthetised, weighed and measured (see later this chapter). They are then implanted with a Passive Internal Transponder (PIT) tag (Central Animal Records, Keysborough, Victoria). These can be read with a Trovan® scanner and so enable individual identification of each fish. The tag is implanted intraperitoneally using a commercial applicator (Fig 4).

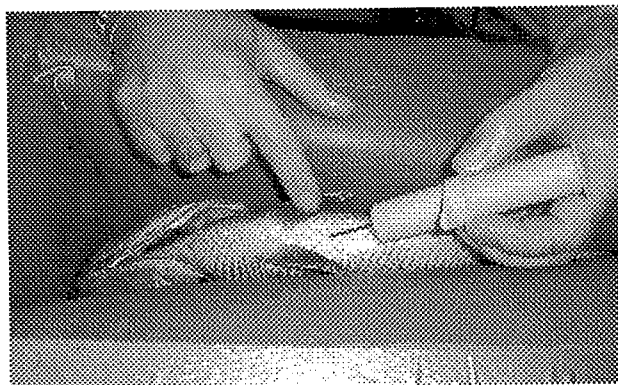

**Figure 4:** Dhufish broodstock being implanted with a PIT tag using a commercial applicator

Fish are then transported to the appropriate broodstock tank.

## 4.3 Tank design

WA dhufish broodstock at the ADU were held in cylindro-conical tanks ranging in size from 25,000 to 40,000 L. Smaller tanks have been trialed, but were unsatisfactory, as the larger fish did not feed and the females did not sexually mature (F.Pironet-Bosc, Ecloserie d'Ambararata, Aquamen, Moroondava, Madagascar, pers.com. 1999). There are several

reasons for choosing a cylindro-conical tank design for finfish broodstock. Firstly, uneaten food and faeces accumulate in the central bottom region where they can be easily removed by periodically opening the bottom drain. The tank hydrodynamics also promote efficient mixing of the water and hence the maintenance of homogenous conditions. Further, the design ensures that any fertilised eggs in the surface waters of the tank are delivered to the

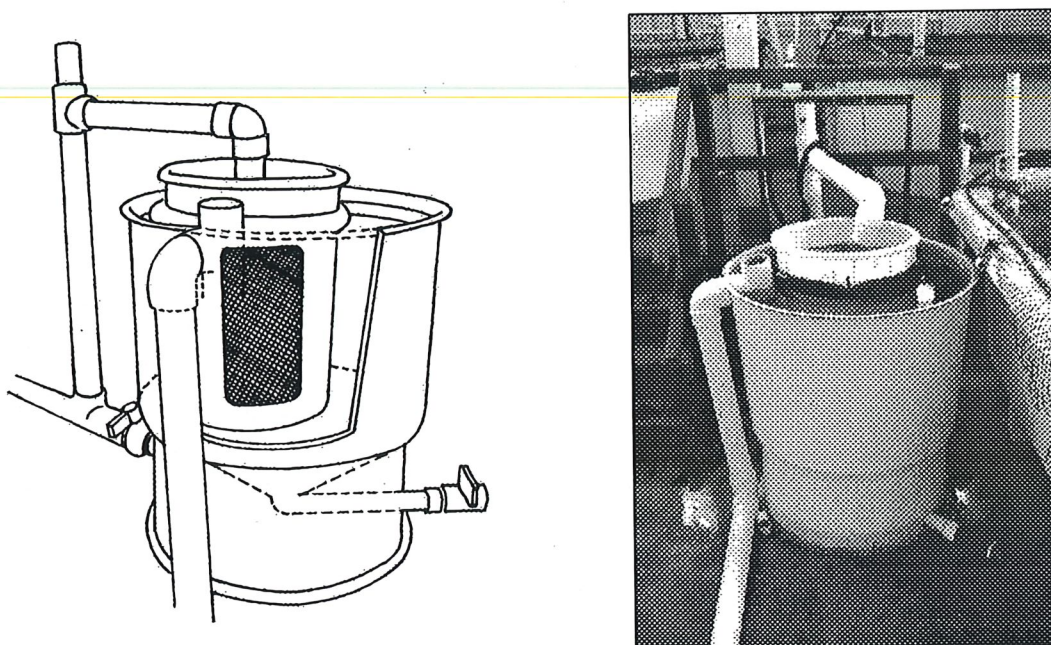

**Figure 5: Floating egg collector**

egg collector in the outflow.

Although in-tank spawning is very rare in acclimated dhufish (only two fish spawned in 5 years of research), each tank is fitted with an egg collector as a precaution. Dhufish eggs are positively buoyant. The water level in the broodstock tank is set by an overflow opening, or pipe, which directs the overflow water to an egg collector (Fig 5). The eggs are thus skimmed from the surface of the tank and collected in an egg net, set within the egg collection vessel, as the water is discharged. A water flow rate equivalent to approximately eight tank volumes per day is provided to the broodstock tanks to ensure that all of the eggs are collected within 12 hours of spawning.

#### **4.4 Husbandry**

Dhufish are relatively sedentary fish, however, they are prone to being startled by loud noises, rapid movements and sudden changes in light intensity. Therefore all tanks must be fitted with a well-secured net, to prevent the fish from jumping out. In addition, all tanks containing dhufish broodstock at the ADU were partially covered with black plastic to provide a shaded area. The dhufish tend to prefer the shade, only coming out in the open for feeding.



The maximum stocking density required for holding dhufish broodstock, while still allowing reproductive development has not been investigated. At the ADU, stocking density was kept low, at less than 1kg of fish per 1000L. It has been found that only 1 male per tank (and usually the largest one) sexually matures (Appendix J). For this reason only two males are placed in each broodstock tank with one being substantially larger than the other. Although only the largest male would be expected to mature, if the larger male is in poor condition and so fails to mature, the smaller male is likely to mature in its place. Five or six females are placed in each tank. Fish up to 8kg have been held successfully, however, at the ADU fish between 3 and 6 kg were preferred. This is a compromise between the egg production potential (larger fish usually produce more eggs) and ease of handling.

At the ADU there are two sources of salt-water: salt-water bore and ocean water. Ocean water is pumped from the ocean, while bore salt-water is pumped from 18m below the ground approximately 10m from the shoreline. Ocean water was the preferred water source as initial trials of holding wild-caught dhufish in bore-water were unsuccessful, with many fish dying after 6 months of exposure to the bore-water (Appendix B). Interestingly, some hatchery-reared dhufish have been held in bore-water for more than three years and remain healthy. Bore water at the ADU has high carbon dioxide levels and low pH. These, or a combination of these features are thought to be the cause of the problems experienced with holding wild-caught dhufish in borewater at the ADU. Bore-water however has several advantages over ocean water as it is not influenced by weather and tidal conditions, has a more stable temperature and is easier to maintain due to reduce filtration requirements. Trials were undertaken to see if the bore-water could be made more suitable for rearing dhufish by degassing.

Each broodstock tank was supplied with air and ocean water filtered to 10 $\mu$ m (nominal). Both recirculation and flow through systems were used for dhufish broodstock. Ocean water temperature ranges annually between 15 and 26°C. Optimal temperatures have not been determined, however, it is likely that temperature between 16 and 23°C is most suitable. These temperatures are similar to those experienced in the wild (Pearce, 1991) and the incidence of exophthalmia appears to increase at temperatures above 23°C (Dr F. Stephens, School of Veterinary Studies, Murdoch University, pers. com, 2000). pH of ocean water is normally between 8.1 and 8.2 with salinity ranging between 33 and 35 ppt.

The ADU broodstock tanks were vacuumed regularly to prevent build up of waste products on the tank bottom. The drain valve was also regularly purged. Uneaten food was removed by dip-net soon after feeding.

Dhufish are very sensitive to poor water quality and developed keratitis on three occasions following: their exposure to short periods of stagnant water (on two occasions); and after decayed food was removed from a tank (one occasion; F.Pironet-Bosc, Ecloserie d'Ambararata, Aquamen, Moroondava, Madagascar, pers.com. 1999). Following exposure to

the poor water quality, the fish immediately ceased feeding and the lens of their eyes turned cloudy. On one of these occasions, all the fish in the tank died within 10 days of the occurrence. This emphasises the need to be vigilant in maintaining tank hygiene.

#### *4.5 Feeding and nutrition*

Feeding provides a good opportunity for assessing the health of broodstock, as decreased appetite is often an indicator of poor health. For this reason, an accurate record of fish behaviour, feed intake and composition should be maintained. In broodstock tanks which typically contain a small number of fish (less than 10), it is possible to identify each fish based on size and external markings. Close observation during feeding can therefore yield information on the health of individual fish.

Little is currently known about the nutritional requirements of dhufish broodstock. At the ADU, dhufish broodstock were fed a rotating diet of freshly-thawed frozen garfish, mullet, pilchards, squid, whiting, prawns and octopus. In the wild, wrasse comprises the majority of the diet (reviewed in McKay, 1997), however, a reliable source of wrasse was not identified and was not a major component of the captive broodstock diet. Once thawed, the food may be chopped to an appropriate size, however, dhufish have a large mouth and can consume food that is large relative to their body size. A fish of 1kg or greater can consume a 15 cm pilchard. Dhufish broodstock are discerning feeders, and will ignore poor quality seafood. Wild-caught broodstock have accepted moist pellets (Appendix D), however, these were not used regularly at the ADU. Hatchery-reared broodstock readily accept moist pellets and these were fed regularly to supplement the flesh diet.

The diet for wild-caught and hatchery-reared broodstock was supplemented regularly with vitamins and minerals (Appendix C). In addition wild-caught broodstock were also treated with the glucan immunostimulant Macrogard® (Vetafarm). For wild-caught broodstock, vitamins/minerals and Macrogard® were administered together in a gelatine capsule in a ratio of 6 to 1. The capsule is inserted into the feed prior to feeding. Approximately 0.6 g of vitamins/minerals and 0.1g Macrogard® were given per kilogram of fish at each feed. Capsules were administered 3 times a week for two weeks every month. For hatchery-reared broodstock, the vitamins were incorporated in a moist pellet (at an inclusion rate of 0.5%/kg) and no Macrogard® was given. The vitamin-enriched pellet comprised about 20% of the total diet (see Appendix D for recipe for the moist pellet).

## 4.6 Handling

### Crowding

When dhufish require handling for a treatment such as a fresh water bath, the fish are herded into a crowd. The crowd is constructed of a buoyant hoop (1.3m in diameter) with a thick cylindrical plastic "bag" constructed of black builders plastic (300mm deep) attached around the edge of the hoop. The fish are slowly herded into the crowd by sinking the leading edge of the crowd to allow the fish to swim in. In the large broodstock tanks the water level is lowered to knee depth and 3 or 4 people are used to quietly herd the fish into the crowd (Fig 6). While the water level is low, the fish are generally quiet and compliant, as long as sudden movements do not startle them. Once the fish are in the crowd, it is covered with a clear plastic cover. The cover is secured with strong clips to prevent the fish jumping out during anaesthesia or other treatment. Both black and white crowds have been trialed at the ADU. The fish generally appear more settled in black crowds, however, in tanks which are all white (rather than the usual dark walls and white floor) a white crowd is generally better, as the fish will not enter into a black one. Crowds of 300 L and 450 L have been used successfully and are recommended. Up to ten 2kg fish or three 6kg fish are held in each crowd.



**Figure 6: Crowding dhufish broodstock using circular floating crowd.**

## Anaesthesia

### Disclaimer

The importation, purchase and use of chemicals to treat animals (including fish) in Australia is controlled through the National Registration Authority for Agriculture and Veterinary Chemicals. Information on chemicals and dosage rates are provided in this document, based on published data, for specific life stages of individual species under laboratory conditions. The provision of the chemical and dose rate information in this document does not infer that the chemicals may be legally used for aquaculture in Australia. Some of the stated products in this text are unregistered, or not registered for the particular use. This should not be interpreted as a recommendation for use and the authors of this publication take no responsibility for losses should these chemicals or dosages be used in aquaculture. It is an offence to import and supply unregistered chemicals and the supply must be authorised by either a veterinary prescription or a permit. Farmers should check the current registration status of chemicals with the National Registration Authority (02) 6272 5158, or <http://www.nra.gov.au> prior to consideration.

Broodstock require occasional handling to check gonadal condition or to administer medical or hormone treatments. For all such procedures anaesthesia is recommended. Dhufish are generally anaesthetised in a floating crowd. Occasionally the anaesthetic is added directly to the tank, however this is expensive and is normally only done if the volume of water can be reduced to less than 1500L (to reduce the amount of anaesthetic required). During anaesthesia, oxygen is always supplied.

Two anaesthetics were regularly used to anaesthetise dhufish broodstock: AQUI-S (AQUI-S New Zealand Ltd) and 2-phenoxyethanol (Sigma cat. no. P1126).

- AQUI-S is derived from clove oil and is reported to be non-toxic to humans, although gloves are always worn as a precaution. At  $0.02 \text{ mL.L}^{-1}$ , AQUI-S is used for procedures which require light sedation, such as administering injections, taking blood samples, weighing, measuring, transporting and conducting ovarian biopsies. AQUI-S at  $0.07 \text{ mL.L}^{-1}$  is used for heavier sedation. AQUI-S was not found to be suitable for full surgical anaesthesia in dhufish. AQUI-S is dissolved in fresh water before use. Oxygenation must be kept to a minimum to prevent the anaesthetic foaming on the surface. The solution should be added slowly to ensure it mixes thoroughly in the crowd. The action of AQUI-S is very gradual and so the anaesthetic is added slowly and the reaction of the fish observed carefully to prevent over-dose.
- 2-phenoxyethanol (0.3ppt) can induce full surgical anaesthesia. It is reported to be highly toxic and so full precautions must be taken when handling the chemical (eg gloves and eyewear). Due to its toxicity, the use of this anaesthetic was limited to occasions where full surgical anaesthesia was required such as stripping. 2-phenoxyethanol must be completely dissolved before adding to the crowd. Undissolved 2-phenoxyethanol appears to irritate the fish and causes violent thrashing. Therefore, the required volume of the anaesthetic is added to a 2L bottle containing fresh water. The bottle is shaken to

aid mixing, and then left to stand. The undissolved anaesthetic will settle to the bottom and the dissolved portion can then be decanted into the crowd. This process is repeated until sufficient dissolved anaesthetic has been administered. Although not as gradual as AQUI-S, the action of 2-phenoxyethanol is still quite slow and so is also made gradually.

Once the required level of anaesthesia is reached, the fish can be removed from the water and various procedures performed. Following the procedure the fish are revived. To revive the fish it is placed in anaesthetic-free water. Using smooth gloves, the fish should be held by the lower jaw and the caudal peduncle and moved gently backward and forward. This forces water over the gills. Alternatively the gills of the fish can be held over an air-stone bubbling air or oxygen. Fish recovering from 2-phenoxyethanol-induced anaesthesia tend to recover suddenly and may dart out of the reviver's hand. This may damage the fish if it strikes the wall of the tank. Fish recovering AQUI-S-induced anaesthesia recover very slowly and may take 5 minutes before they regain buoyancy. During this time they tend to swim on their side on the bottom of the tank. This may damage the eyes or cause other abrasions if the tank surface is not completely smooth. Therefore, once the fish are ventilating, they are normally released into a floating crowd (described above) until full buoyancy is regained.

### Handling procedures

Once anaesthetised, the fish can be removed from the water and various procedures performed. Gloves are always worn when handling dhufish to prevent mucous loss. Dhufish have large, protruding eyes, which are prone to damage during handling. Problems include superficial damage to the cornea and haemorrhage and swelling of the eyeball (see section 8.3.2). For this reason, a number of systems have been designed for working specifically with dhufish in order to prevent eye damage.

- Following anaesthesia the fish are normally transported in a sling, closed at one end. Smaller fish may be moved, without anaesthesia, in a covered tub containing water, large enough to hold them comfortably. This is sometimes easier as it avoids the need for anaesthetics, but is not recommended for fish heavier than 2kg.

- The fish can be placed on a flat, but soft surface, such as a block of high-density foam covered in plastic. A section of the foam is cut away, to create a hollow for the eye to rest in, thereby eliminating contact of the eye with any surface. This is suitable for some minor procedures, and also those that require access to the whole fish.

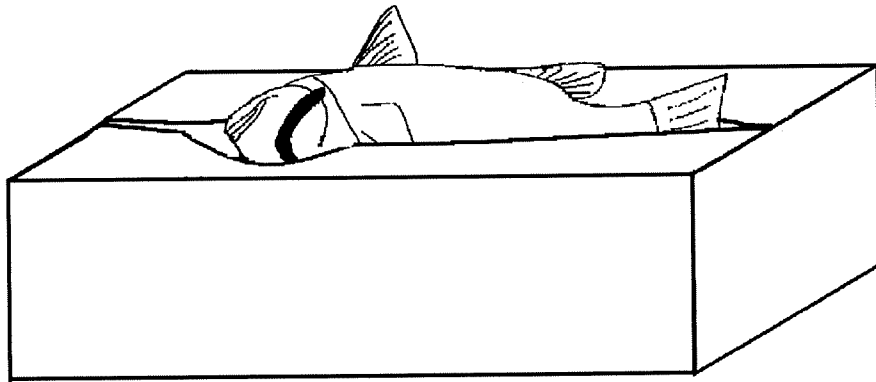

**Figure 7: Dhufish in a foam restraint.**

- A foam restraint is useful for procedures that require access to the ventral surface only such as blood sampling, implanting hormone pellets and pit tags, administering intramuscular and intra-peritoneal injection, and conducting ovarian biopsies (Fig 7; adapted from N.W. Pankhurst, School of Aquaculture, University of Tasmania, pers.com. 1994). The restraint is a large, deep block of high-density foam (at least 1 ½ x the dimensions of the fish) with a slit cut length-wise into the centre. This slit is shaped at one end to create a gap large enough to fit the head and eyes comfortably (this alleviates pressure on the eyes). The remainder of the slit should be kept narrow to ensure firm pressure along the body. The slit and block are then covered in plastic. The plastic covering should be wet prior to use to prevent damage through abrasion. An anaesthetised fish can then be inserted deeply into the plastic covered foam, belly up. The advantage of this system is that the fish is safely restrained, allowing the operator to concentrate on their task.

- For weighing and measuring, a hanging cradle is used (Fig 8). It is constructed of 6 mm PVC sheet and is designed to hang from a spring balance. A large hole is cut in the region where the eye would lie, to prevent the eye from resting on the hard plastic. Graduations on the cradle allow simultaneous measurements of length and weight.

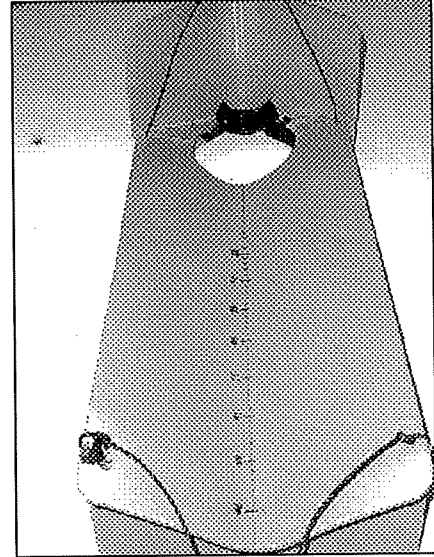
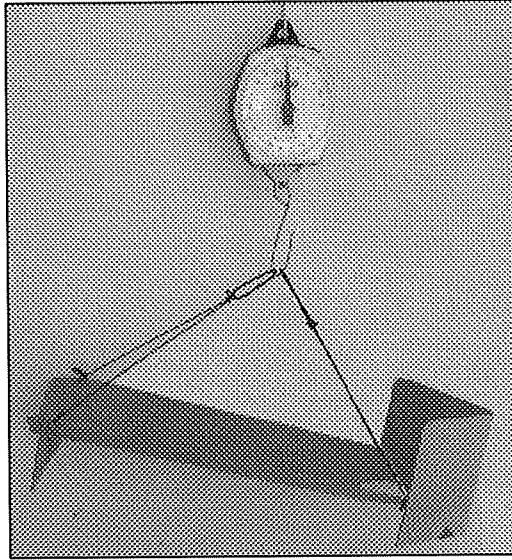

**Figure 8: Cradle for weighing and measuring dhufish.**

## Chapter 5: Reproduction

### 5.1 Overview

Although some species of marine finfish can complete sexual maturation in captivity, for many species normal maturation through to spawning does not occur under culture conditions. This is usually due to stress imposed by the culture environment (reviewed in Pankhurst, 1998). In some cases, the species may acclimate given sufficient time (perhaps several years), however, as is the case with snapper *Pagrus auratus*, a truly domesticated stock (ie grown in captivity from eggs) needs to be produced before the species will spontaneously complete sexual maturation and spawn in captivity. Wild-caught acclimated snapper do not normally ovulate or spawn naturally in captivity (Cleary, 1997). Hatchery-reared snapper do however spawn readily in tanks. At the ADU, hatchery-reared snapper spawn unaided in their tanks on a daily, year round basis. In the absence of spawning broodstock (either acclimated or domesticated) hormonal intervention is required to artificially stimulate the fish to complete maturation.

Female dhufish caught from the wild and acclimated to the culture environment do not naturally complete maturation; they usually fail to ovulate (release of eggs from ovarian tissue into the oviduct) and consequently fail to spawn (release of eggs from oviduct into water column following courtship behaviour). In this regard, dhufish are similar to snapper. At the ADU, 95 hatchery-reared dhufish approached first maturity during the summer of 2000. These fish were suspected of being all females and, if this was the case, the lack of males would have inhibited spawning. Acclimated males (caught from the wild) were stocked with the hatchery-reared fish in late 2000 and yet natural spawning has not occurred in the subsequent two years.

In-tank spawning is the preferred means of collecting eggs, as it avoids the complications of hormone treatment and stripping. In the absence of spawning hatchery-reared dhufish however, hormone therapy is required to stimulate maturation and ovulation. On two occasions (during the 5 years of research), female dhufish have spawned in the tank following hormone treatment. The eggs were fertilised by the resident male. This, however, is rare and the fish normally need to be stripped. Trials were conducted to try to reliably stimulate spawning using hormones. These have not been successful (Appendix F).

### 5.2 Hormones

#### Disclaimer

The importation, purchase and use of chemicals to treat animals (including fish) in Australia is controlled through the National Registration Authority for Agriculture and Veterinary Chemicals. Information on chemicals and dosage rates are provided in this document, based on published data, for specific life stages of individual species under laboratory conditions. The provision of the chemical and dose rate information in this document does not infer that the chemicals may be legally used for



aquaculture in Australia. Some of the stated products in this text are unregistered, or not registered for the particular use. This should not be interpreted as a recommendation for use and the authors of this publication take no responsibility for losses should these chemicals or dosages be used in aquaculture. It is an offence to import and supply unregistered chemicals and the supply must be authorised by either a veterinary prescription or a permit. Farmers should check the current registration status of chemicals with the National Registration Authority (02) 6272 5158, or <http://www.nra.gov.au> prior to consideration.

In a reproductively healthy female, Gonadotropin Releasing Hormones (GnRH), produced by the hypothalamus, trigger the release of Gonadotropins (GtH) from the pituitary. The GtHs then stimulate the production of reproductive steroids, which in turn cause oocyte maturation and ovulation (Fig 9). There are two main approaches to artificially inducing ovulation in fish: treatment with GtH or GnRH preparations. GtH preparations mimic the action of the fish's natural gonadotropin and so stimulate the production of reproductive steroids and in turn stimulate final oocyte maturation and ovulation. Human chorionic gonadotropin (hCG) and pituitary extracts are examples of this. In contrast, GnRH preparations mimic the fish's natural GnRH, and act directly on the pituitary to stimulate secretion of the fish's own GtH.

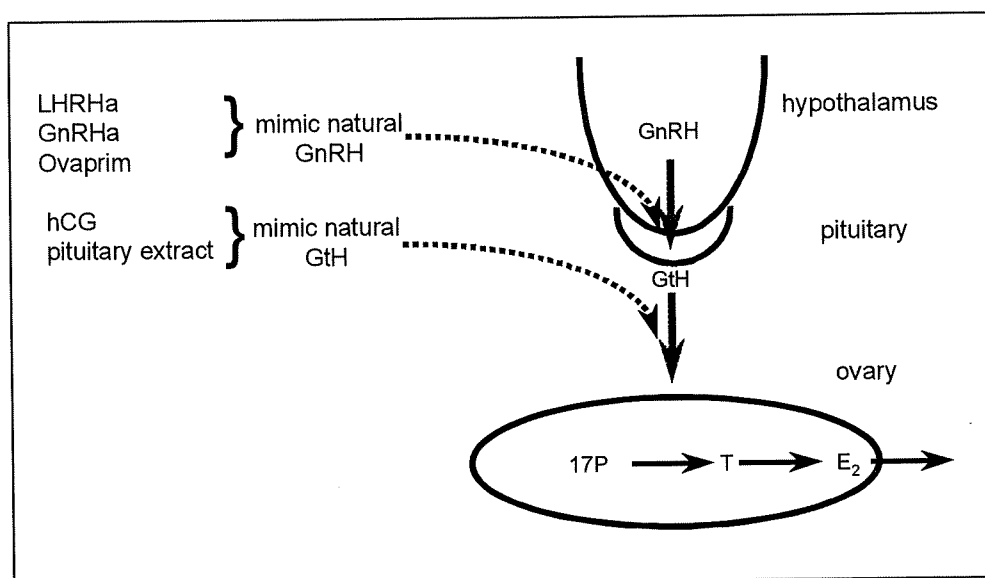

**Figure 9:** The action of LHRHa and hCG on reproduction in marine fish.

GnRH preparations are either purified from a natural source (ie from the same or different species) or can be an analogue (synthetic copy) of a natural GnRH (GnRH<sub>a</sub>). Luteinising Hormone Releasing Hormone analogue (LHRHa) is a GnRH<sub>a</sub> commonly used in fish and is an analogue of a mammalian hormone. In some species, the release of GtH by the pituitary is controlled/down-regulated by naturally occurring dopamine. In these species, it may be necessary to administer GnRH<sub>a</sub> in conjunction with a dopamine antagonist (eg domperidone) to ensure the release of GtH and hence maturation. Ovaprim®, produced specifically for fish, is a commercial product containing GnRH<sub>a</sub> and domperidone.

Three hormones have been trialed on dhufish: hCG, Ovaprim® and LHRHa. HCG may be purchased as Chorulon® produced by Intervet and can be purchased by prescription from veterinary suppliers. This is a commercially prepared product supplied in two vials. One vial contains hCG and the other distilled water. This product is simple to use and may be stored before dilution in the fridge or on ice until use. Alternatively hCG can be purchased from Sigma (Cat. No, C 5297) as a powder. This can then be dissolved in saline or distilled water. For ease of use, the solution can be made ahead of time, frozen in appropriately sized aliquots and thawed when required. Ovaprim® is supplied as a viscous liquid from Syndel. It may be stored in the fridge and is administered by injection as supplied. LHRHa (Des-Gly<sup>10</sup>(D-Ala<sup>6</sup>) luteinising hormone releasing hormone ethylamide salt; Sigma L4513) is either dissolved in saline solution (as for hCG) or prepared as a pelletised implant containing 95% cholesterol and 5% cophal oil (Lee *et al*, 1986; see Appendix E). Pellets and LHRHa solutions can be made in advance and stored in the freezer in appropriately sized vials. All hormones stored in the freezer should be discarded, in an environmentally appropriate manner, 2 days after thawing. All dissolved hormones are administered in sterile syringes with 18 – 25 gauge needles. Implants are administered using a large bore needle (1.8 mm internal diameter, 2.2 mm external diameter) with an internal shaft. At the ADU recycled needles (as supplied with microchip PIT tags) are used successfully for administering implants (Fig 4). These are stored in alcohol between use. All hormones are administered intraperitoneally (ie into the abdominal cavity). LHRHa administered in a pellet is most commonly used at the ADU with acclimated male and female dhufish (Appendix G & J). Chorulon® (hCG) is used with sexually mature females caught during the spawning season (Appendix H). There are indications that Ovaprim® is also useful in inducing ovulation, however, this has not been tested in a controlled manner and was not regularly used at the ADU on dhufish.

### **5.3 Egg production**

#### **5.3.1 Sources of eggs**

##### *Acclimated females*

Females should be caught in shallow water (preferably <20m) from the wild during winter and spring and held in tanks as per Chapter 4. During the expected spawning season, females should be observed closely for evidence of maturity. As the developing oocytes undergo vitellogenesis, they increase in size. This results in a swelling of the ovaries and hence the abdomen. When most of the fish in a particular tank have swollen abdomens, all the sexually mature females in that tank are treated with hormones to stimulate final oocyte maturation and ovulation. To achieve this, the tank is drained as quickly as possible to reduce the period of time in which the fish are acutely stressed prior to hormone treatment. The fish are then anaesthetised, weighed, measured and an ovarian biopsy performed on females.

Ovarian biopsies are conducted to determine the stage of sexual maturity of developing oocytes, both to determine if or when hormones need to be applied and to predict the time of ovulation (and therefore when stripping is required). This is always performed under anaesthesia. A biopsy tube or cannula (a hollow surgical tube of maximum 3mm outer diameter and minimum internal diameter of 1.5mm), is gently inserted into the oviduct (the opening closest to the tail in the vent area). A commercial endometrial biopsy cannula can also be used. A sample of the gonad is then taken by either sucking the surgical tube or working the plunger of the commercial cannula as the tube is withdrawn from the oviduct. The sample secured in the cannula is then ejected into a drop of seawater on a slide and examined under a microscope fitted with a measuring graticule. The diameter of the ten largest oocytes (developing eggs) is measured and the mean (or average) diameter calculated.

Female dhufish with a mean oocyte diameter of greater than 400 $\mu$ m are likely to respond to the hormone and are treated. LHRHa (administered by saline injection or slow-release pellet), hCG and Ovaprim® have been used with some success on acclimated females. An LHRHa pellet is now the hormone of choice. Doses as low as 5:g.kg<sup>-1</sup> (slow-release cholesterol pellet) have been successful in inducing ovulation, however, the results have been unreliable. LHRHa pellet at a dose of 50:g.kg<sup>-1</sup> is sufficient to stimulate ovulation in the majority of fish (oocyte diameter of > 500 $\mu$ m) within 24 to 96h of implant and is therefore recommended (Appendix G). Following hormone treatment, the females are transferred to a smaller easily accessible tank where they can be monitored closely. A 4000L tank was used for this purpose at the ADU.

#### *Wild-caught females*

Eggs may also be obtained from sexually mature females caught from the wild during the natural spawning season (Appendix H). Fish should be caught from shallow water (<30m). The best time to catch sexually mature females in shallow water is early in the spawning season (usually mid-December to mid-January). After this time the dhufish appear to migrate to deeper waters and so are difficult to catch in shallow waters.

Fish should be caught by handline. Immediately after capture the swimbladder should be deflated (see Section 4.1), the fish placed in a foam restraint (Fig. 7) and an ovarian biopsy conducted. The biopsy should be examined to determine if the fish is sexually mature. If it is not possible to have a microscope on the boat then, with practice, this can be done crudely by eye. Sexually mature females (ie those with vitellogenic, hydrating or ovulated oocytes should be injected with hCG at 1000 IU.kg<sup>-1</sup>. Weight can be estimated from a measure of the length of the fish to avoid the difficult task of weighing fish at sea (Appendix J). The fish is then released into the transport tank. All of these procedures can be performed without anaesthetics if a properly constructed foam restraint is used. The use of anaesthetics at sea

is not recommended due to the risk to workers of splashing onto skin and eyes. After treatment the fish are then transported to a land-based facility in an appropriately sized tank with a close fitting lid, and supplied with oxygen (Section 4.1). At the land-based facility they are placed in easily accessible tanks for close monitoring as for acclimated fish above.

### *Hatchery-reared females*

At the ADU a stock of ninety 3+ year old hatchery-reared dhufish were maintained. Some of these fish reached sexual maturity in the summer of 1999/2000, although they did not spawn. Interestingly, no males were positively identified amongst these fish, either through gonadal biopsy or external morphology (ie. elongated rays on dorsal fin). The absence of males would explain the lack of spawning on this occasion. Wild-caught males were added to the tanks in late 2000 and natural spawning still did not subsequently occur in these fish. These fish were not used in trials for hormonal induction of ovulation.

### *Comparison of egg sources*

Although advances were made in terms of securing a reliable supply of good quality fertilised eggs, the maximum annual egg production for dhufish was 1.5 million. This is insufficient to support an industry. During the 1999/2000 season, success was achieved in obtaining and fertilising eggs from females caught from the wild during the spawning season, making available another source of eggs. Collection of sexually mature females in suitable physical condition is time consuming and is therefore expensive. However, this must be weighed against the cost of maintaining large numbers of captive broodstock year round: broodstock must be held in large tanks and are fed high quality food. Had hatchery-reared dhufish reached sexual maturity and had spawned successfully in their tanks, without the need to administer exogenous hormones, egg production would have eclipsed production from all other sources. This would be particularly true if attempts to stimulate hatchery-reared dhufish to spawn out of season using photo-therm manipulation had been successful. Hormonal induction of ovulation and stripping of fish caught from the wild will, however, remain important to maintain genetic diversity (particularly in early days when hatchery-reared fish come from limited numbers of broodstock), replace stock after a disease outbreak, or for advanced genetic manipulation (triploid, hybridisation). A sensible approach to egg production would be to incorporate all three sources of eggs in such a way as to take advantage of the benefits offered by each.

### *Monitoring egg development and ovulation*

All externally fertilising species of fish have a window of post-ovulatory viability (ie the period after ovulation in which eggs retain the ability to be fertilised) after which egg viability declines with time (reviewed in Hobby and Pankhurst, 1997). The period of peak fertility varies

between species and ranges from several hours (eg snapper) to several weeks (eg trout). Reliable stripping of good quality eggs is dependent on the correct estimate of the length of this window, for the species in question. In captive female dhufish, viability was found to decrease to 50% within 3-5h of ovulation (Cleary *et al*, 1999; Appendix I). Therefore the fish need to be monitored closely so that eggs can be stripped and fertilised as soon as possible after ovulation. For this reason, once females were treated with the hormone at the ADU they were placed in a 4000L tank where they could easily be observed and lightly anaesthetised for ovarian biopsy. This simplified the process of regular monitoring of egg development.

At the time of hormone treatment, oocyte diameters are greater than 500 $\mu$ m. Oocyte diameter gradually increases. During this time biopsies are conducted every 12h. After the oocytes reach 800 $\mu$ m, they begin to hydrate (the final stage of egg development before ovulation). In acclimated female dhufish, this will normally only occur following hormone treatment. When this stage is reached it is likely that the female will ovulate within the next 12h and the fish should be monitored closely. A fully hydrated egg is normally between 1000 and 1200 $\mu$ m in diameter. Ovulation occurs soon after hydration is completed. The point when the hydrated (clear and large) oocytes have separated from the ovarian tissue (and other smaller developing eggs) can be identified from a biopsy sample. Alternatively, applying light pressure to the abdomen should cause any ovulated eggs to flow freely out of the oviduct, provided the oviduct is not blocked. As a female approaches ovulation, a source of sperm must be located (Section 5.4) before the female is stripped (Section 5.5).

#### **5.4 Sperm collection, storage and quality assessment**

Male dhufish typically produce small volumes of sperm. In many other cultured species, the testis comprises 5-10% of the total body weight during the spawning season (eg black bream, snapper), and they typically produce large amounts of sperm. In contrast, the testes of the male dhufish weighs as little as 0.1% of the body weight during the spawning season (Hesp and Potter, 2000), and they typically produce less than 1 ml of sperm at a time. Therefore, securing a reliable supply of dhufish sperm is more difficult than for many other cultured species.

##### **5.4.1 Source of sperm**

When a female is approaching ovulation, a source of sperm must be located. There are potentially three main sources of dhufish sperm available: sperm stripped from live acclimated males; sperm collected from the testes of fish caught from the wild; and cryopreserved sperm. Due to the limited supply of sperm from male dhufish, all these sources of sperm need to be utilised optimally to enable a regular supply.

## *Acclimated males*

### Stripping

Male dhufish will spermiate in captivity, however, it has been found that only one male per tank will spermiate. This is usually the largest, dominant male. A smaller male will spermiate if the larger one is removed or is ill. For this reason, it was common practice at the ADU for each broodstock tank to contain only two males (one larger and one smaller).

When a female is approaching ovulation an acclimated male is selected and anaesthetised. As this procedure requires the fish to spend a long period out of the water, it is important that a high degree of anaesthesia is attained. For this reason 2-phenoxyethanol is used at 0.3 ppt. Once anaesthetised, the abdominal region of the fish is rinsed with freshwater and gently towel dried to remove traces of salt water and anaesthetic. The fish is then stripped by applying pressure along the abdomen, beginning at the front of the fish (behind the pectoral fins), and moving toward the vent. A plastic apron and gloves are always worn when stripping dhufish to prevent damage to the protective mucous layer. The sperm is collected in a sterile 1-2 ml syringe as it exudes from the vent (Fig 10). When sperm is stripped it is inactive (ie cells are immobile) whereas upon contact with salt water, the sperm activates (ie becomes

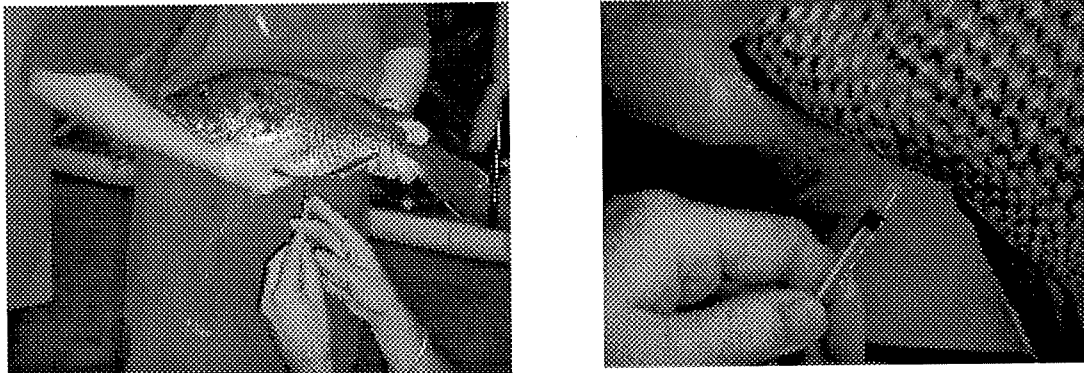

**Figure 10: Stripping male dhufish**

mobile). Once activated, sperm will be viable for only as long as it remains mobile (maximum of several minutes). To prevent activation, care must be taken to avoid contamination with seawater and the sperm should not be allowed to pool on the body surface before collection. The syringe containing the collected sperm is capped after collection and inactive sperm can be stored on ice for long periods of time (up to several days).

### Sperm quality

The quality of the sperm is assessed before use by placing a minute drop of sperm onto a glass microscope slide with a cover slip and viewing with a compound microscope at 40x magnification. Inactive sperm cells appear as immobile dots, while active cells swim rapidly across the field of view. Any sperm cells vibrating on the spot, but not swimming are

considered to be inactive. An approximation of the number of active cells as a percentage of the total number of cells in the field of view is made. This is repeated at different positions on the slide and the average of these measures gives the activity of that sperm sample. If care has been taken to avoid contamination with seawater, all sperm should be inactive (ie immobile). If the sperm has been activated, that sperm sample is discarded. Slides and cover slips must be very clean, as residual salt is sufficient to activate sperm and may result in sperm being incorrectly discarded.

If the sperm is inactive then a single drop of seawater is placed along the edge of the cover slip. The water will be drawn under the cover slip by capillary action and will contact the sperm. Immediately after the salt water is added, activity is checked again as above. The higher the percentage of active cells the better the quality of the sperm. Sperm that is less than 70% active is normally discarded, if better quality sperm is available.

#### Storage

Once collected, inactive sperm can be stored on ice in the collection syringe. The quality of the inactive sperm will deteriorate with time (normally over several days, but sometimes over several hours). To ensure sperm is of the highest available quality, sperm should be collected as close to the time of ovulation as possible. Optimally, two males should be stripped to maximise the chance of successful fertilisation and hatch.

#### Ensuring supply

Although male dhufish readily spermiate in captivity, the small number of spermiating fish per tank and the small sperm volume produced per fish necessitates that each spermiating male be stripped regularly during the spawning season. Repeated handling and stripping over a period of 1 week reduces the volume of sperm available, as well as the number of fish spermiating (Appendix J). Treating the fish with an LHRHa implant ( $10:g.kg^{-1}$ ) can overcome the negative effects of the stress of handling and stripping, by maintaining sperm production (Cleary *et al*, 1999). Therefore an implant of LHRHa ( $10:g.kg^{-1}$ ) was regularly used at the ADU to maintain sperm supplies during the spawning season. Problems however, have been experienced in storing sperm stimulated by LHRHa implants. Sperm that isn't used immediately after stripping of LHRHa implanted fish appears to rapidly decline in quality (as determined by activity). This aspect needs to be investigated further.

#### *Testes from wild-caught males*

Due to the limitations in sperm production of acclimated dhufish, it is necessary to supplement the hatchery sperm supply with sperm from wild-caught males. In addition to stripping acclimated males, sperm has been collected from freshly killed dhufish caught from the wild

by professional or recreational fishermen (Appendix K). Testes were collected from sexually mature males from the fish markets, fishing competitions, and directly from individual recreational fishermen. The quality of the sperm (determined by activity) appears to be dependant on the length of time the fish have been dead, how well the fish has been chilled after death (the colder the better, but not frozen), and the length of time the testes have been removed from the fish. Dhufish at the fish markets are usually well chilled, however, have usually been dead for more than 72h. Average sperm activity from the fish that were sampled was as low as 27% and unsuitable for use in fertilising eggs. Average activity of sperm from fish caught at fishing competitions was 64% which is adequate (although not optimal) for fertilising eggs. These fish were killed up to 10 hours before the testes were removed from the fish. Due to logistical constraints, once removed from the fish, the testes were stored in airtight plastic bags on ice for approximately 5 hours before the activity was measured. There is anecdotal evidence to suggest that testes stored within the abdominal cavity of the fish (well chilled) will retain higher sperm activity for longer, compared with testes stored in plastic bags. Although this has not been tested in a controlled manner, the current recommended means of short-term storage of testes is to leave them in the fish and to chill the fish well. The efficacy of stripping freshly-caught wild males has not been explored.

### *Cryopreservation*

Due to the limited supply of sperm supply from male dhufish, a small number of trials were undertaken to develop techniques for cryopreserving sperm. Cryopreservation offers potential for storing sperm for long periods of time. There are a number of different techniques developed for various species. The success of cryopreservation varies among species and among techniques. Therefore techniques must be optimised for each species.

Early trials were successful in freezing and thawing dhufish sperm at the ADU and the thawed sperm has been used to fertilise eggs. Fertilisation and subsequent hatch however, have been low compared with eggs fertilised with fresh sperm.

The best technique developed at the ADU (see Appendix L) involves gradual dilution of dhufish sperm with a diluent containing DMSO (6.25%) and glycerol (5%) in a teleost ringers base. A known volume of sperm is added to a sterile 1.2 ml cryogenic vial. Diluent is added in four equal portions, each portion being equivalent to the volume of the sperm being preserved. The rate of dilution must be very slow to avoid osmotic shock, and a delay of at least 30 seconds is observed between successive additions. The vial containing the sperm and diluent is gently mixed during this time. These procedures should be carried out on ice, and all equipment used must be sterile before use to avoid contaminating the sample. Once the dilution is completed, the vial is capped, labelled and attached to a storage cane. The sample is then suspended in liquid nitrogen vapour just above the level of the liquid nitrogen for 5 minutes. The vial is then plunged into the liquid nitrogen. Frozen sperm is then stored



in the liquid nitrogen dewar until required. Thawing is conducted in a warm water bath (30 to 40°C) for 1.5 minutes.

### 5.5 Stripping and fertilisation

Once sperm is collected, monitoring of the female is continued, by taking regular ovarian biopsies until ovulation is detected. The female is then anaesthetised deeply using 2-phenoxyethanol (0.3 ppt) and prepared for stripping as for males. The eggs are collected in a clean and dry measuring cylinder with a large funnel (Fig 11). When eggs contact seawater

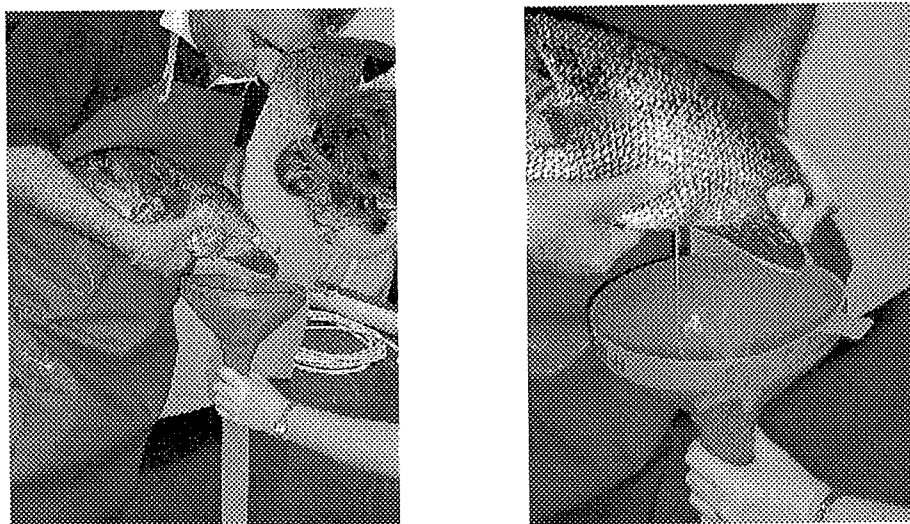

Figure 11: Stripping female dhufish

they harden, rendering them impermeable to sperm. For this reason, the abdominal region must be rinsed well with fresh water and gently dried prior to stripping.

The total number of buoyant eggs stripped from individual acclimated females at the ADU following treatment with an LHRHa pellet at 50:g.kg<sup>-1</sup>, ranged from 24,000 to 300,000 over 3 consecutive strippings, 24h apart (Appendix G). A female dhufish held in a 3,000,000 L public aquarium (AQWA, Sorrento, WA) produced a total of 700,000 eggs over 5 consecutive nights following hormone treatment with LHRHa pellet at 50:g.kg<sup>-1</sup>. The total number of eggs obtained from individual females caught from the wild during the spawning season and treated with hCG (1000IU kg<sup>-1</sup>) ranged between 63,000 and 105,000 over four consecutive nights (Appendix H). Once ovulated, the eggs are transferred to a clean and dry 1 L glass beaker for fertilisation. The eggs are very fragile at this time and so the transfer should be conducted gently. Sperm or macerated testes is added to the eggs and gently mixed to ensure the sperm is well dispersed amongst the eggs. Seawater is added to the eggs (volume equivalent to six times the volume of the eggs) with further gentle mixing for several minutes. The suspension is then left to stand for a further 10 minutes before being transferred to the counting cone.

### 5.6 Rinsing and counting eggs

All eggs produced, whether by spawning or stripping, are transferred to a counting cone for counting and rinsing. The ADU counting cone is a 100L cylindro-conical polypropylene cone with volumetric graduations on the vertical walls (Fig 12). A gentle flow of seawater ( $\approx 1 \text{ L} \cdot \text{min}^{-1}$ ) is added directly to the cone to rinse the eggs. The overflow water is removed from the cone by a permanent siphon with the intake screened to retain the eggs in the cone (Fig 13). Rinsing is continued until the water is clear, which can take up to 60 minutes.

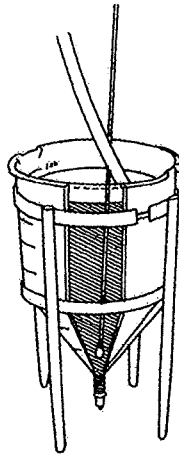

Figure 12: Egg counting cone

Once rinsed, the siphon is removed and the eggs are aerated vigorously to ensure uniform distribution. A minimum of six 5ml samples are then taken from the tank using an autopipette. Each sample is dispensed onto a taut piece of 500  $\mu\text{m}$  mesh where the eggs can be seen and counted. The six counts are averaged, then divided by 5 to obtain the average number of eggs per millilitre. To obtain the total number of eggs in the cone, this value is then multiplied by the volume of the tank.

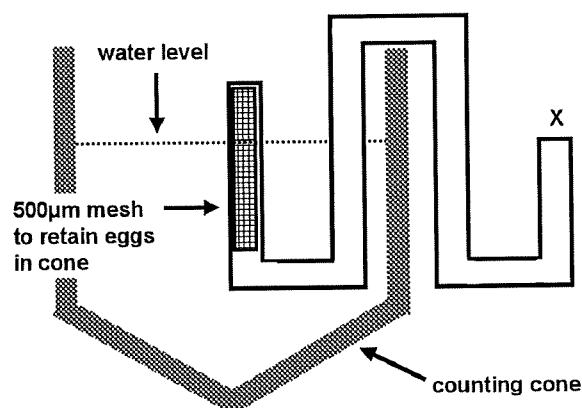

Figure 13: Permanent siphon. If the siphon is completely filled with water (ie no air bubbles) then it will continue to remove excess water whenever the water level rises above the top of the outlet column (marked X).

## 5.7 Egg quality

Rearing marine fish larvae requires expenditure of time, effort and money. As larval survival and quality are highly dependent on egg quality, only the highest quality eggs are selected to maximise production efficiency. At the ADU, three methods are used to evaluate egg quality, namely buoyancy, fertilisation rate and early larval survival.

The first method relies on the premise that good-quality eggs, having a high lipid content, are positively buoyant, whilst those that sink are infertile, over-ripe or immature (Foscarini, 1988). In order to calculate viability, the total egg number is firstly determined as described above. The air-stone is removed from the counting cone and the eggs left standing for approximately 20 minutes. The good-quality eggs float whilst the poor-quality eggs sink to the bottom of the tank. The negatively buoyant eggs are then removed by opening the valve at the bottom and draining at least 10L of water. The air-stone is then added and the counting procedure is repeated to determine the number of viable eggs. Percentage viability is calculated using the following equation:

$$V = \frac{N_V}{N_T} \times 100\%$$

Where:

$V$  = viability (%);

$N_V$  = number of viable eggs;

$N_T$  = total number of eggs

If the viability of a batch of eggs is less than 80%, the quality of the eggs is likely to be inadequate for cost effective larval rearing. To confirm the quality of the eggs, an estimate of the fertilisation success can be made using a dissecting microscope. Fertilisation can be detected within two hours of its occurrence, when cell division is at the 2 or 4 cell stage. For an accurate measurement it is best to wait a further 6-12 hours before checking. By this stage the developing embryos will be clearly visible. Infertile eggs, on the other hand, will show no development, or development will have halted at an earlier stage of cell division. A good batch of eggs will have a very high fertilisation rate, usually greater than 90%.

Larval survival during the first two days post-hatch is perhaps the most accurate and reliable indicator of egg quality. Good-quality eggs provide the developing embryo with enough nutrients and energy to fuel early development until exogenous feeding commences. If newly hatched larvae from poor-quality eggs are stocked directly into larval rearing tanks, they may suffer high mortalities before exogenous feeding commences, due to a lack of endogenous reserves. High, early mortalities may be difficult to determine, especially in green-water cultures where small larvae can be difficult to see. It may be several days or weeks before heavy mortalities are evident, by which time substantial staff resources and funds have already been invested in the culture. At the ADU, dhufish larvae were maintained in the egg incubators (Fig 14) until the second or third day and an estimate of survival made before they are stocked into rearing tanks. If good-quality eggs are stocked into the incubators, survival to

Day 2 (where Day 0 is the day of hatch) should be greater than 50%, and the presumably good-quality larvae can be stocked into the rearing tanks.

Viability, fertility, hatch and survival to day 2 of dhufish eggs/larvae were highly variable (Appendix G and H). Egg viability was as high as 95%, however it was more common for a viability of 50%. Mean viability of eggs stripped from acclimated females treated with LHRHa at  $50\mu\text{g.kg}^{-1}$  was approximately 90% on the first ovulation, however, decreased with successive ovulations, and was 40% by the third ovulation (Appendix H). Fertility (expressed as a percentage of viable eggs) was normally low, being less than 60% on most occasions, however at times was as high as 95%. Hatch (expressed as a percentage of fertilised eggs) was also normally low, with percentages of 50% or less being common, although hatch rates as high as 80% were also observed.

### 5.8 Incubation, larval harvesting and counting

Following counting, eggs are transferred to the incubation cone. The ADU incubation cone is a 40L cylindro-conical fibreglass cone with  $350\mu\text{m}$  screened windows in the vertical walls. The cone has in-built buoyancy and floats inside a larger tank filled with seawater (Fig 14). To eliminate the need to later transfer the larvae to a new tank, the incubation cone should be floated in the larval rearing tank if possible. Very light aeration (sufficient to gently maintain eggs in suspension) is supplied directly to the counting cone through an open-ended airline attached to the base of the cone. Incoming water, filtered to  $10\mu\text{m}$  (nominal), is passed through a degassing column and fed into the tank. The flow rate is set at  $6\text{ L.minute}^{-1}$ . Water will diffuse through the mesh into the counting cone and so dilute waste products. Water overflows from the larval rearing tank through a  $250\mu\text{m}$  screen.

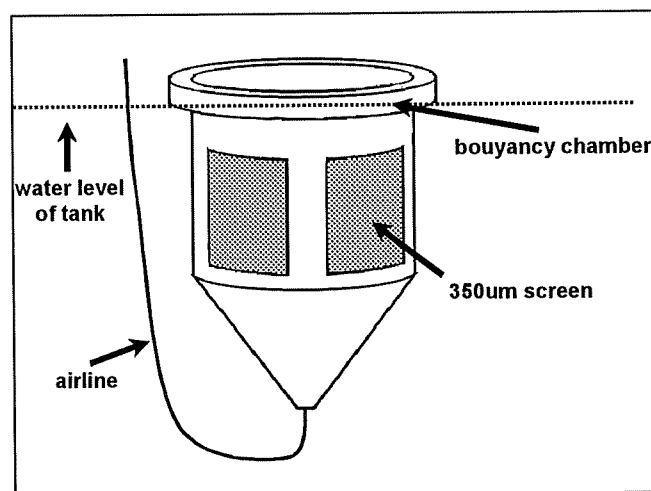

Figure 14: Floating incubation cone

The egg transfer from the counting cone to the incubation cone is conducted by turning off air and water to enable buoyant eggs to float to the surface. The eggs are then ladled carefully off the surface using a 1L beaker and transferred directly to the incubation cone. Each incubation cone is stocked with a maximum of 2000 eggs.L<sup>-1</sup>. During incubation, the tanks are kept in the dark (ie covered with black plastic or incubated in a darkened room). Hatching time is dependent on temperature; at 23°C, hatching occurs within 32h. "Dead" eggs are removed regularly (at least twice per day). This is done by turning off the air for 5 to 10 minutes. Dead eggs will settle to the bottom, while good eggs will move to the surface. The dead eggs can then be vacuumed up using a small siphon (eg a length of airline attached to a rod).

On hatch and on day 2 or 3 post-hatch, the larvae are counted. First the air is turned off to allow all dead larvae, eggs and waste to settle. These are vacuumed up using a small siphon as above. When the cone is clean, aeration is increased to aid even distribution of the larvae within the cone. Dhufish larvae are strong swimmers and so gentle stirring using a plastic paddle may also be necessary to ensure even distribution. The period of mixing is kept to a minimum to avoid damaging the fragile larvae. The effect of counting in this manner on larval survival was not determined. At least six, 10 ml samples are counted in a petri dish to estimate the total number of larvae in the cone (by calculating average number of larvae per millilitre, and multiplying by the volume of the cone). The larvae are then stocked directly into the larval rearing tank by gently submerging the lip of the incubation cone and allowing the larvae to flow out.

It may be inconvenient at times to float the incubators within the larval tank itself. In such cases, the larvae must be transferred from the incubating tank to the larval rearing tank on day 2 or 3 post hatch. The first step is to ensure that the water quality parameters (especially water temperature), of each tank are as similar as possible to minimise shock. The air and water are then turned off to the incubation cone, to encourage the larvae to swim to the surface. The larvae are then carefully ladled off the surface in 1 L or larger beakers. The full beakers are then carried and stocked into the larval rearing tank. To minimise stress, the beaker should be floated in the larval rearing tank and the water in the beaker changed gradually over a period of 10 minutes. The larvae are then released into the tank by submerging the beaker and allowing larvae to flow out. Stress can be further minimised by conducting the transfer in dull light.

## Chapter 6: Larviculture

Co-author: Gavin Partridge, Aquaculture Development Unit

### 6.1 Overview

Rearing marine finfish larvae requires close attention to a number of important parameters including temperature, salinity, pH, tank design, lighting and the size and nutritional composition of the food that is offered. In general, larval rearing methods for marine finfish can be classified into three categories: intensive, semi-intensive and extensive.

Standard intensive methods involve rearing larvae at high densities in flowing, clean seawater. Sophisticated filtration equipment and precise temperature and lighting control are often used to maintain hygienic conditions and control over the rearing process. Effective intensive methods are comparatively expensive in terms of labour and capital. Adding marine microalgae to the larval tank is a popular adaptation to the standard intensive technique. In addition to the more obvious benefits, such as buffering water quality changes and providing a food source for the zooplanktonic prey organisms in the tank, microalgae are also reported to have benefits such as stimulating enzyme synthesis and acting as an immunological stimulant (Lavens *et al.*, 1995).

A less-demanding method of rearing larvae is extensive culture, a method in which eggs or newly hatched larvae are stocked directly into a large tank or pond. The larvae feed on naturally occurring plankton, which proliferate with the addition of inorganic and/or organic fertilisers. Although much cheaper than intensive methods, extensive production can be unreliable due to the dependence on natural plankton blooms and poor or non-existent control over climatic conditions. Growth of larvae in extensive culture is usually excellent, however survival can be inconsistent. Predatory insects, invertebrates and other fish larvae can have a significant impact on survival.

Semi-intensive techniques have attempted to combine the positive features of both intensive and extensive methods. Rearing occurs in tanks with no constant flow and limited water additions/exchanges (called 'static' tanks), in which rotifers are encouraged to proliferate by the regular addition of microalgae. These techniques provide more control over the rearing process than extensive methods and are less costly than standard intensive methods. During 1997/98, a rearing strategy originally developed for barramundi culture (Palmer *et al.*, 1992) was modified at the ADU for improved larviculture of black bream (Partridge *et al.*, 1998; Jenkins *et al.* 1999). Under this semi-intensive green-water system, larvae are reared in static (no flow) 5,000 litre tanks. Rotifers are encouraged to proliferate within the tank by the regular addition of the green microalgae *Nannochloropsis oculata*. Rotifers receive no artificial enrichment and feed only on the microalgae present in the culture. This method resulted in

survival rates of black bream larvae in excess of 80%, compared to an average of 20% under the previous green-water intensive culture system. For a thorough description of the various rearing methods refer to Jenkins *et al* (1999) and Partridge *et al* (1998).

A range of different larval rearing strategies have been trialed to determine the optimal rearing methods for the WA dhufish (Table 1). The rearing strategies tested include clear-water intensive, green-water intensive, green-water semi-intensive (with and without cultured calanoid copepods) and brown-water semi-intensive. These cultures have been conducted in a variety of tank sizes and styles ranging in volume from 140 litres to 5,000 litres. Survival ranged from 0 to 37%. In terms of survival, the most successful system incorporated cultured copepods, with survival being at least 12 times higher than for other methods. That trial, however was conducted on an experimental scale. In 1999/2000, further research was undertaken at the ADU to incorporate cultured copepods into a semi-intensive green-water system, thereby combining the nutritional advantages of copepods with the cost-effective semi-intensive system (See below and Appendices N & O for details on these experiments).

## **6.2 Evolution of a suitable larval rearing system for dhufish**

The clear-water intensive method was first trialed in 1995/96 and 1996/97. The perceived benefits of clear-water intensive culture are hygiene, high water quality and complete control over the rearing environment. In the clear-water intensive method trialed for dhufish at the ADU in 1995/1996, larval rearing tanks received a constant flow of clean water filtered to 1 $\mu$ m absolute by cartridge filtration and sterilised by ultraviolet radiation. Water temperature was maintained between 22 and 24 °C. Larvae were fed rotifers (*Brachionus plicatilis*) at first feed. Later they were weaned to early developmental stages of brine shrimp (*Artemia* sp). The rotifers and artemia were enriched prior to feeding with various artificial enrichment or algae. A total of 18 trials were conducted using this method. Only one of these batches was successful in producing juveniles and survival was low with a maximum survival (to Day 50 post hatch) of 0.01% (Table 1).

Due to the poor results obtained, green-water intensive methods were trialed and microalgae was incorporated into the rearing tank. In the green-water intensive method, larval rearing tanks received a constant flow of clean filtered water as per the clear-water intensive method. In addition, approximately 500,000 cells.mL<sup>-1</sup> of the green microalgae, *Nannochloropsis oculata* (*N. Oculata*) was maintained within the tank during the rotifer-feeding phase. Feeding was as for the clear-water intensive method. This method was attempted on a total of eight batches in 1996/97 and 1998/99. Success was again limited with only one batch producing juveniles (survival 0.01% to day 50 post hatch).

Due to the success of the established semi-intensive method to rear black bream, this was trialed on seven batches of dhufish larvae in 1998/99. Methods were similar to that described for black bream in Jenkins *et al* (1999) and Partridge *et al* (1999). Briefly, a 5000L tank was partly filled with 1200L of 5 $\mu$ m filtered seawater. The water was chlorinated and neutralised before the alga *N. oculata* and rotifers (40.ml<sup>-1</sup>) were added. The larvae were added at a density of 30,000 to 100,000 larvae per tank. Additions of algae and seawater were made regularly in order to maintain suitable water quality parameters. When the tank was full, a water exchange of at least 500L.day<sup>-1</sup> was made to control water quality parameters. Feeding was as for the clearwater intensive system with two exceptions: 1) Rotifers were not artificially enriched as rotifer populations were self-maintained in the tank and no rotifer additions were required throughout the trial; 2) The culture system promotes blooms of other zooplankton, including wild copepods which add to the available food source. The semi-intensive method generally requires less maintenance than for the intensive method and the enrichment and daily addition of rotifers is generally not required during the first two weeks of culture. Due to the more static nature of these systems, water quality is of critical importance and more time is involved in monitoring essential water quality parameters than for intensive methods. Results were variable, however, the maximum survival to Day 50 post hatch was 3%: a result manifold higher than previously obtained for dhufish in any culture system.

As dhufish are a deep water, oceanic species it was considered likely that they would have a higher requirement for highly unsaturated fatty acids (HUFA), compared to the estuarine black bream. *N. oculata*, the background algae species used in standard greenwater cultures at the ADU is low in the HUFA, docosahexaenoic acid (DHA). Therefore a variation was trialed by replacing *N. oculata* with Tahitian *Isochrysis galbana* (*T.Iso*). This culture also resulted in superior survival compared to all previously attempted intensive culture techniques (survival to Day 50 was 1%), but slightly lower than obtained in the standard green-water semi-intensive culture.

At the same time, a highly successful adaptation of the green-water intensive method was developed (1998/99), utilising cultured calanoid copepods (*Gladioferens imparipes*) during the rotifer feeding stage (Rippingale and Payne; Final Report FRDC Project # 96/398; Payne *et al*, 2000). The algae, (*T.Iso*) was added in addition to *N. oculata* as enrichment for the copepods. This was trialed on an experimental scale in 140 L tanks and compared with larvae in similar tanks which were fed rotifers only. Survival in the copepod-fed tanks was high, being 37% to day 50 post hatch, compared with 5% in the tanks fed rotifers only. In addition, growth was significantly higher in the copepod-fed tanks, achieving a length of 11mm by day 23 compared with only 6mm in rotifer only tanks (Payne *et al*, 2000). This trial also demonstrated that dhufish larvae could be reared in small experimental scale tanks. This was an important development as it enables replicated studies with small numbers of larvae.



Table 1 Summary of larviculture trials

Year	Culture Method	Number of batches	Food presented at first feed	Artificial rotifer enrichment ?	Background algae	Tank Size (L)	Maximum Survival to Day 50
1995/96	Clear-water intensive	8	Rotifers	Yes	N/A	300 – 2,000	0.01%
1996/97	Clear-water intensive	10	Rotifers	Yes	N/A	1,000	0%
	Green-water intensive	2	Rotifers	Yes	<i>N. oculata</i>	1,000	0.01%
1998/99	Green-water intensive	6	Rotifers	Yes	<i>N. oculata</i>	1,000	0%
	Green-water semi-intensive	7	Rotifers & naturally occurring copepods	No	<i>N. oculata</i>	5,000	3%
	Brown-water semi-intensive	1	Rotifers & naturally occurring copepods	No	<i>I. galbana</i>	5,000	1%
	Green-water semi-intensive	3	Rotifers	No	<i>N. oculata</i> & <i>I. galbana</i>	140	5%
	Green-water semi-intensive	3	Rotifers & cultured copepods	No	<i>N. oculata</i> & <i>I. galbana</i>	140	37%
1999/2000	Green-water semi-intensive		Rotifers & cultured copepods	No	<i>N. oculata</i> & <i>I. galbana</i>	140-5000	10%
	Green-water aquamat semi-intensive	1	Rotifers & naturally occurring copepods	No	<i>N. oculata</i> & <i>I. galbana</i>	5000	0%

Despite the advantages of cultured copepods to the larvae, the system was conducted in small scale (140L) tanks and was too labour intensive to be commercially viable. Therefore, a system that combined the benefits of cultured copepods with the labour saving commercial scale semi-intensive green water system was investigated. Insufficient production of cultured copepod nauplii was initially a bottleneck to developing such a system. Therefore a system that promoted a self-sustaining population of cultured copepods within the larviculture tank was investigated. Ideally, this would eliminate the need to add copepod nauplii to the tank daily, and so would decrease the total number of intensively cultured copepods required. Preliminary trials, however, indicated that the high densities of *N. oculata* typical to the standard static green-water system were too high for calanoid copepods, resulting in low copepod survival and nauplii production. Full details of these trials can be found in Appendix N & O.

Due to the uncertainties of achieving sufficient copepod production for commercial dhufish larviculture, research continued to maximise survival and growth of dhufish larvae fed solely on rotifers. Dhufish larvae are capable of efficient ingestion and digestion of rotifers. The nutritional content of rotifers can be manipulated by adjustments to enrichment protocols. Therefore a better understanding of the nutritional requirements of dhufish larvae, and subsequent improvements to rotifer enrichment protocols, should result in improved survival, growth and larval vigour.

### 6.3 General larviculture principles

The following are some general comments on larval rearing techniques as they apply to dhufish culture. For a more complete discussion of these and other aspects of marine larval rearing refer to Jenkins *et al* (1999) and Partridge *et al* (1999).

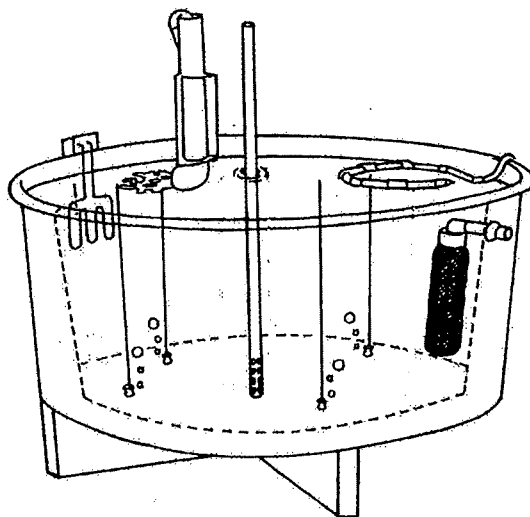
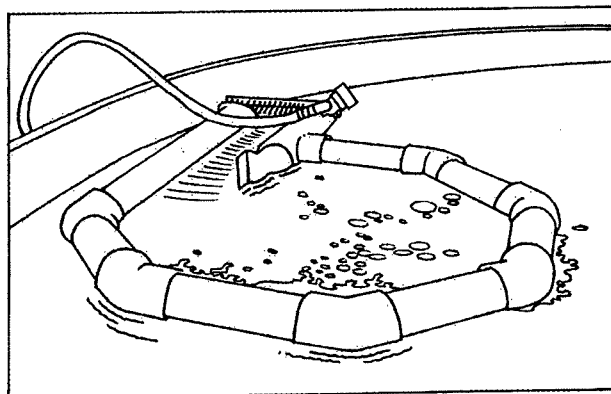

Figure 15: 5000L larval rearing tank

A range of tanks have been used for rearing dhufish larvae ranging in size from 140 to 5000L. All semi-intensive methods have been conducted in 5000L tanks (Fig 15). The bottom of all the tanks are white and the sides either dark blue or black. Tanks with dark-coloured walls are reported to be superior to those with white walls, as the dark colour enhances the visibility of the prey to the larvae. The white bottom enables the culturist to see the larvae and the bottom of the tank. A cylindro-conical tank is preferred due to the superior tank dynamics.

Although it is possible to follow a 'recipe' for culturing marine finfish larvae, successful results will only be obtained through close observation of the culture and the larvae themselves. Monitoring the progress of the developing larvae, by microscopic observation, is a very important aspect of larval rearing. Important information such as feeding response, growth rates and swim bladder inflation can all be gathered from these observations. At the ADU, observations are made by selecting and examining approximately ten larvae from the tank every day during such times as first rotifer feeding, swim bladder inflation, and rotifer/artemia weaning, and on alternate days outside of these periods.

Food consumption is quantified by assigning a 'score' of 0, 50 or 100% to the fullness of each larva's gut. These observations are particularly important at first feeding and during the transition from one food type to another, because they provide an indication of how well larvae are adapting to the new food type.



**Figure 16: Surface skimmer**

Growth is assessed by measuring the standard length of the larvae using an ocular micrometer fitted to the eyepiece of a dissecting microscope. Larval growth is highly dependent on temperature and food availability. Newly hatched dhufish larvae are 1.75-2.10 mm in body length (Pironet and Neira 1998; Appendix M)). As a guide, larvae should reach 5 mm by Day 15 and 10 mm by Day 30.

A critical stage of larval development of many cultured species is swim bladder inflation. Larvae initiate swim bladder inflation at night by 'gulping' air from the surface and passing it through their pneumatic duct into their swim bladders. This process can only occur within a narrow window of time. An oily film on the water surface increases the surface tension, which

can prevent the small larvae from breaking through and gulping air. Surface skimmers are therefore added to the larval rearing tank from Day 2 to remove surface film (Fig 16). The skimmers operate by passing a stream of air across the surface of the water into an enclosed area, in which proteins and oils accumulate and are periodically removed. Larvae with inflated swim bladders have an air-filled cavity above the stomach and are easily identified under the microscope.

Swimbladder inflation begins on about Day 3 or 4 for dhufish. The proportion of fish with evidence of swimbladder inflation should be determined daily during this period, as this gives an indication of the health of the larvae and whether skimmers are operating effectively. Dhufish larvae have not demonstrated difficulty in inflating swim bladders in tanks fitted with surface skimmers. In all dhufish trials conducted, 100% of larvae have inflated swim bladders by day 8 post-hatch.

#### 6.4 Summary of developmental stages

Dhufish larvae hatch within 32h of fertilisation at 23°C (Fig 17). Yolk sac larvae are 1.75 to 2.10 mm long (Fig 18). First feed occurs on day 3 or 4, at a length of 2-3mm. Swimbladder inflation occurs simultaneously, with 100% inflation occurring between Day 3 and 8, and at a length of 2 to 4mm. Artemia feeding commences at a larval length of approximately 5mm. Metamorphosis is complete by Day 40 to 45, and at a larval length of 8mm (Fig 19; Pironet and Neira, 1998; Appendix M).

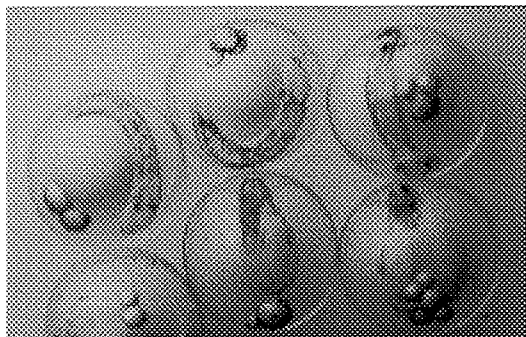

Figure 17: Dhufish eggs undergoing organogenesis

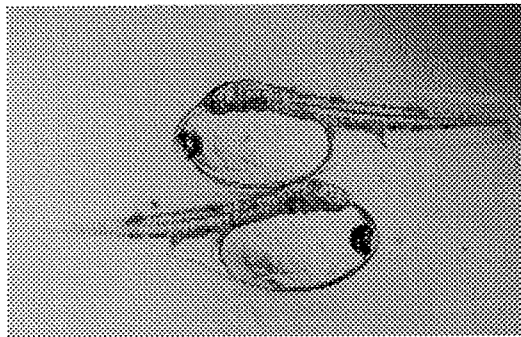

Figure 18: Newly hatched dhufish larvae

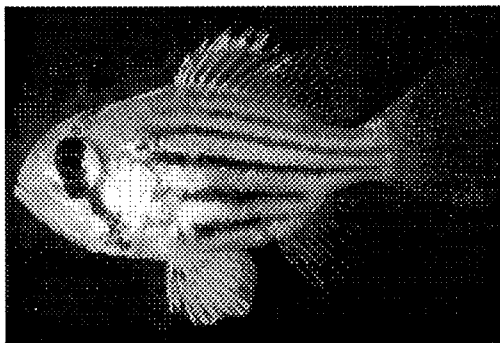

Figure 19: Fully metamorphosed juvenile dhufish (Photo courtesy of Barry Hutchins)

## **6.5 Weaning to a pellet**

Weaning involves a gradual change in the primary food source from live artemia to an inert pellet. At the beginning of weaning, artemia levels are maintained, and small amounts of the pellet are added regularly. Gradually the amount of pellet is increased, while the amount of artemia is decreased. The reduction in available artemia encourages the larvae to accept the pellet. For a weaning diet to be effective it must be readily ingested, highly digestible and contain the correct balance of essential and non-essential nutrients. The standard weaning diet used at the ADU for black bream and snapper is an imported formulation, known as Nippai ML. This is a highly effective diet for weaning black bream and snapper. Initial attempts to wean dhufish using this standard technique were unsuccessful, as the dhufish did not accept the diet.

To identify a successful weaning strategy for dhufish, a series of trials were conducted comparing various methods of presenting the artificial pellet (Nippai ML). In one trial three different weaning diets were used: 1) Nippai ML; 2) Nippai ML coated with fish emulsion and 3) a gelatine-based pellet containing Nippai ML and fish flesh. The first two diets were used throughout the entire weaning period. In the third diet, the proportion of flesh was initially high, and the Nippai ML was low. Gradually the proportion of fish flesh was reduced to 0%, while the proportion of Nippai ML was increased to 100% (Appendix P). The acceptance of Nippai ML and coated Nippai ML (first two treatments) was poor, and groups of fish weaned straight onto this pellet suffered high mortality and slow growth. Weaning using the gelatine-based pellet was more effective than both Nippai ML and coated Nippai ML, with a lower mortality (10% cf 40%). The superior performance of the gelatine-based pellet, compared with the commercial diet appears to be due to increased attractiveness to the fish. Preparation of the gelatine pellet, however, is labour intensive.

Only a slow wean (over 30 days) was attempted with dhufish and only with fully metamorphosed juveniles. Weaning of marine fish is normally conducted at a much younger age, and over a shorter period of time than has been successful for dhufish (see Jenkins *et al*, 1999).

## **6.6 Harvest and survival estimates**

At the ADU, marine fish larvae other than dhufish are routinely harvested by feeding water, via gravity, through the bottom drain of the larval tank into a reservoir fitted with a suitably sized net. Various methods are in use or are being developed at the ADU for estimating larval survival with marine fish larvae. These methods include estimating by volume when larvae are concentrated in a small volume of water both with and without anaesthetic (similar to estimating for hatchlings) and the use of a fish counter (which counts each larva as it passes through a beam of infra-red light). Refer to Jenkins *et al* (1999) for more details.

Due to the comparatively small number of dhufish cultured to date, these methods for harvest and estimating survival have not been fully explored for their suitability for use with dhufish

larvae. The only harvest method used routinely on dhufish was to drain the tank to a depth of 20 cm and scoop out fish, a few at a time, using a net or small beaker. Fish are then counted as they are transferred to a new tank. This is a highly accurate but time consuming method, particularly for large numbers of fish. Furthermore, it has only been performed on fully metamorphosed fish and would not be suitable for younger larvae.

## Chapter 7: Nursery and grow-out

Very little information is available in regard to optimal diets, conditions or systems suitable for grow-out. Less than 2000 dhufish were grown in captivity beyond the nursery stage.

### 7.1 Husbandry

Juvenile dhufish have been held in 300-25,000L tanks (depending on the number of fish), supplied with aeration and with filtered seawater. Dhufish have not been trialed in seacages. The effect of stocking density on the growth rate of juvenile dhufish has not been investigated. Dhufish juveniles are currently held at stocking densities of up to 4kg.tonne<sup>-1</sup>. Normal temperature range is 17-22 °C. As dhufish are prone to jumping when startled, all tanks must be covered with a well secured net. For this reason tanks were preferably located in low-traffic areas. Cylindro-conical tanks are preferred for ease of tank maintenance. Tanks are vacuumed and the drain valve purged daily to remove faeces and waste food.

### 7.2 Grading

As with all marine finfish, growth rate can vary greatly between individuals. This can cause problems in the nursery as larger fish can show aggression to smaller fish and out-compete them for food. Although dhufish are not aggressive or cannibalistic, it may be necessary to grade them during their commercial culture to reduce competition and ensure equal access to food.

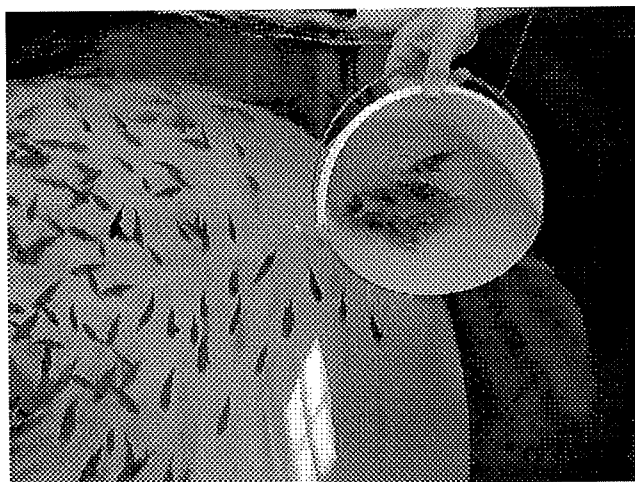

A passive grader may be used for grading dhufish. This is a large box with equally spaced

**Figure 20:** Juvenile dhufish being stocked into a new tank following grading

metal rods in the base. An appropriately spaced grid should be selected to ensure the desired grade. Unlike snapper and black bream, dhufish do not swim down through the grid, therefore, the grader must be completely lifted out of the water briefly to encourage the smaller fish to pass through. The larger fish are then retained in the grader and are transferred to another tank or tub (Fig 20). Refer to Jenkins *et al* (1999) for more details.

### **7.3 Feeding and nutrition**

Little is known about nutritional requirements for juvenile dhufish. Many health problems are evident in the juveniles that appear to be a consequence of inadequate nutrition. The most distinct of these is "fatty liver" syndrome. Although many cultured species exhibit fatty livers, the severity of the problem in dhufish is extreme. The problem first became evident in fish fed on a commercial pellet (protein:energy ratio of 40:15). Severe fatty livers, coupled with low, but constant mortality led to all fish being fed a flesh diet (supplemented with vitamins and minerals). The change in diet temporarily abated the mortalities, however, the livers did not improve and the fish remained plagued by poor health. At the time, the fish were being fed a rotational diet of thawed, freshly frozen pilchards, prawns, squid and whitebait. In an effort to reduce the fat in the diet, pilchards were replaced by garfish, mullet and whiting. Subsequent liver histology from juvenile dhufish indicated that the fatty livers were substantially improved. It is likely that the change in diet contributed to this improvement.

The subsequent diet for dhufish juveniles at the ADU was a rotational diet of garfish, mullet, whiting, whitebait and prawns, all chopped to an appropriate size. Fish were fed to satiety once to three times daily, depending on the size of the fish. Satiety for dhufish held at the ADU was 3% of body weight (wet weight). Dhufish juveniles also readily accept a moist pellet. The pellet was adapted from Glencross *et al* (1999) and contains 30% flesh in a gluten base (Appendix D). Fish were fed the moist pellet twice per week. This enabled the diet to be supplemented with additional vitamins and/or therapeutics.

When the juvenile dhufish were fed on the commercial pellet, acceptance of the pellet was good, although feeding was less vigorous than for flesh-fed fish and growth appeared slower. Dhufish juveniles fed on pellets are slow feeders and are particularly well suited to an automatic feeder. Fish were fed at about 1-2% of body weight (dry pellet to wet body weight).

Investigations to define specific nutritional requirements for dhufish for the purpose of developing a suitable pelletised diet were commenced during the term of the project. Amino acid composition of the flesh of dhufish was found to be similar to that observed for other species (Glencross *et al*, in review; Appendix Q). Native fatty acid composition, however, was significantly higher in arachidonic and decosahexaenoic acids, and lower in eicosapentaenoic acid than typically observed in standard commercial fish oils. This data suggests that standard protein resources, provided digestible limits are observed, will suffice for this



species. However, use of fish oil as the only lipid resource may not be sufficient to satisfy essential fatty acid requirements. The next step in developing a pelletised grow-out diet suitable for this species is a detailed examination of the dietary and energy requirements for this species.

#### 7.4 Growth rates

Limited long-term data on growth of hatchery-reared juveniles has been collected. This was due to the small number of dhufish produced in the early years of the project (Cohort 1997-1). Due to their potential high value as future broodstock, these fish were not subjected to frequent weight-ins. Instead, these fish were weighed opportunistically whenever the fish were being handled for another reason. Later batches of fish were weighed more regularly (Cohorts 1999-1, 1999-2, 2000-1), however this data extends only to 400 days, due to the age of the fish. Wet weight of these four different cohorts of hatchery-reared dhufish are shown in Figure 21.

Growth in three of the four cohorts (1999-1, 1999-2, 2000-1) followed a similar curve. These fish reached approximately 100g in 400 days. The weight of the fish in cohort 1997-1 was significantly higher than this at approximately 400 days with fish having attained 280g; almost three times that of the other three cohort. The rearing conditions between the faster growing 1997-1 and the other three cohorts varied considerably.

- *Water temperature*: Average temperature for the 1997-1 fish over the first 400 days was  $22.4^{\circ}\text{C} \pm 0.5$ , while in the other fish it was  $20.5^{\circ}\text{C} \pm 0.5$ ; a difference of  $2^{\circ}\text{C}$ . The effect of temperature on growth has not been investigated for dhufish, however, these data suggest that the effect may be considerable.

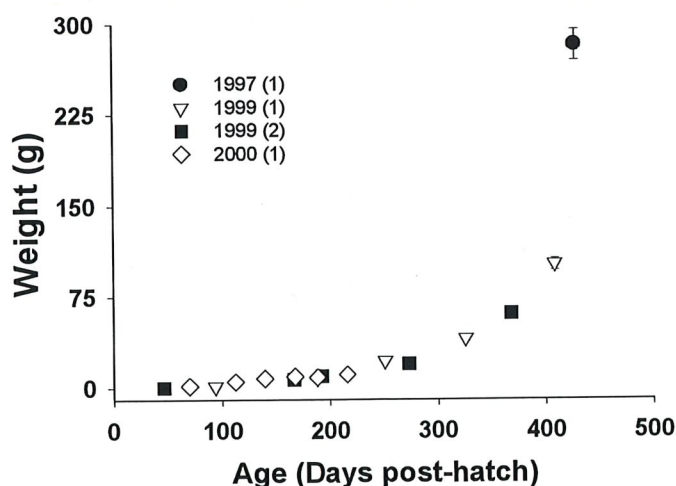

**Figure 21:** Wet weight of dhufish juveniles from four different cohorts of eggs. Values are means  $\pm$  SE.

- *Stocking density:* 1997-1 fish were held in a 25,000L tank and at day 400 stocking density was only 1.33 g.L<sup>-1</sup> (based on 95 fish at 280g each). In contrast, the other three cohorts were held in much smaller 2,500L tanks and at 400 days, stocking density was approximately 8g.L<sup>-1</sup> (based on 200 fish at 100g each); a 6-fold difference in stocking density. It is possible, although unlikely that this higher stocking density may have impaired growth. Optimum stocking density has not been investigated however even 8g.L<sup>-1</sup> is not high for marine finfish grow-out, and so is thought to be less significant than water temperature.

In one year (ie 365 days), dhufish in the wild reach approximately 100mm (Hesp and Potter, 2000), which corresponds to approximately 27g wet weight. Therefore growth of dhufish in even the slowest growing hatchery-reared cohorts was more than 3 times faster than in the wild. The increased growth rate exhibited by the hatchery-reared fish is likely to be due to the increased quantity of food available, reduced foraging effort and presumably increased temperature, although the preferred temperature of juvenile dhufish in the wild is unknown.

The maximum growth rate achieved above is still very slow for an aquaculture species.

## Chapter 8: Health and disease management

### Disclaimer

The importation, purchase and use of chemicals to treat animals (including fish) in Australia is controlled through the National Registration Authority for Agriculture and Veterinary Chemicals. Information on chemicals and dosage rates are provided in this document, based on published data, for specific life stages of individual species under laboratory conditions. The provision of the chemical and dose rate information in this document does not infer that the chemicals may be legally used for aquaculture in Australia. Some of the stated products in this text are unregistered, or not registered for the particular use. This should not be interpreted as a recommendation for use and the authors of this publication take no responsibility for losses should these chemicals or dosages be used in aquaculture. It is an offence to import and supply unregistered chemicals and the supply must be authorised by either a veterinary prescription or a permit. Farmers should check the current registration status of chemicals with the National Registration Authority (02) 6272 5158, or <http://www.nra.gov.au> prior to consideration.

In the wild, dhufish live in waters deeper than 10 metres and with a temperature range of 19 to 22°C (Pearce, 1991). In the culture environment dhufish are held in conditions that are vastly different to their natural habitat: tanks are shallower (from 1 to 3m in depth), temperature variations are broader (16-26°C), stocking densities are higher and the diet is different. In addition, daily activity and routine hatchery procedures, combine to impose considerable stress on captive wild dhufish. The end result of such stress is an increased predisposition to disease (Pickering 1998).

The three most common health issues encountered with captive dhufish are

1. exophthalmos ("pop-eye")
2. heavy monogenean (gill fluke) infestation
3. various bacterial, fungal and protozoan infections

Dhufish appear to be sensitive to many chemical therapeutics normally used on other cultured fish. This factor makes treatment of some diseases more difficult. Issues relating to dhufish health were investigated by Dr Fran Stephens of the School of Veterinary Biology and Biomedical Science, Murdoch University (See 8.4, Non-technical Summary, Final Report FRDC Project #98/328).

### **8.1 Disease recognition**

Early recognition of potential disease problems is important in diagnosing the cause of the disease and implementing appropriate treatments. Careful observation is the best way to recognise disease problems. Signs that dhufish are unhealthy or stressed include:

- Dark colouration
- Weight loss (cranial bones more obvious than usual)

- Abnormal behaviour eg reduced appetite, fish remaining alone in a dark part of the tank.
- Red or swollen areas on the body of the fish
- Tattered fins and/or tail
- "Flashing" or rubbing against tank surfaces
- Increased ventilation
- Stationing of the fish at air sources or water inlets

## **8.2 Disease diagnosis**

It is important to diagnose the cause of a disease problem before starting treatment. All handling and treatments will further stress the fish and may result in increased problems if the treatments are inappropriate.

The first step to diagnosing health problems with dhufish is to carefully watch resting fish to observe their appearance, behaviour and lesions, together with an examination of records of feed intake, water parameters and mortality. Secondly, analysis of the culture water should be undertaken. It is important to consider the environmental and management factors that may contribute to fish stress and increased pre-disposition to disease, as such factors are often the key to preventing a recurrence of the same problem.

Following consideration of the history of the fish and environmental factors, some affected fish can be anaesthetised and a gill biopsy and skin scraping performed. A gill biopsy involves sampling a small portion of the gill filaments. Sterile surgical scissors should be used and the gill sample placed in a vial containing seawater. Some bleeding may occur from the gills. The gill filaments and skin scrapings are then observed on a glass slide under a microscope. Motile protozoan parasites, fungal hyphae and metazoan parasites such as gill fluke will be visible under low power if the fish is heavily infested. For a comprehensive description of these techniques and of the organisms likely to be found, see the Fisheries WA publication "Fish Health for Fish Farmers in Western Australia" (Thorne, 1995).

For further diagnosis, live or freshly dead fish can be submitted for a full post mortem and further tests to the Fish Pathologist at the Department of Fisheries, Government of Western Australia, Fish Health Unit located at the Department of Agriculture in South Perth or the equivalent agency in other states. If it is not possible to submit a whole fish the following procedures may help to obtain a diagnosis.

- Skin lesions can be swabbed with a sterile swab, held on ice and submitted for bacterial and fungal culture.

- Pieces of gill and internal organs up to 1.5cm in diameter can be removed from freshly dead fish, placed in 10% buffered formalin and submitted to the Fish Pathologist.

### **8.3 Identified diseases and their treatments**

#### 8.3.1 Infectious diseases

##### *Gill fluke*

Two species of Monogenea have been identified in dhufish. The most prevalent is *Haliotrema abaddon* (Kritsky and Stephens 2001). The other is an unidentified member of the subfamily *Axinae*. The latter parasite was not detected in the last 3 years of the project. *H. abaddon* is the most problematic pathogen of captive dhufish. Heavily infested fish become dark in colour, lose their appetite and may station themselves above airstones or increase their rate of opercula movement. Populations of gill fluke in captive fish increase with increasing water temperature, hence most problems occur during late spring and summer if the infestation is not controlled.

*H. abaddon* is very resistant to many treatments, and the margin of safety between an effective dose and a safe dose is very narrow for many common treatments. Trials conducted under FRDC project 98/328, identified three potential treatments: trichlorphon, praziquantel and freshwater bath (Stephens, Cleary et al. 2003).

##### Freshwater bath

This treatment is routinely administered to captive dhufish, newly arrived to the hatchery, during the quarantine period and 2 times per year as a prophylactic control measure (and at other times if required). This treatment is effective in removing isopods and copepods from the skin and nares and removes the majority of gill fluke. The treatment is presumed to be not effective against eggs and cysts of some parasites, therefore, it is repeated after 14 days to prevent reinfection by newly hatched parasites. The freshwater bath is used successfully on both broodstock and juveniles, although extra care is taken with the small fish due to their increased susceptibility to osmotic stress.

The treatment is administered in a small volume of water (250 to 1500L), to maximise the rate of water exchange and therefore the rate of salinity decrease. At the ADU floating crowds, 250L-1000L tubs and 4000L tanks with lowered water level have been used. Fish undergoing quarantine are normally treated in the 4000L quarantine tank. Fish in large broodstock tanks are lightly anaesthetised with AQUI-S (0.2 ppm) and transferred to a 250 to 1000L tank for treatment. While the treatment is underway the tank can be cleaned and then refilled. Tank cleaning is easier if the fish are removed from the tank for treatment, rather than being left in a crowd floating in the tank during cleaning.

Once the fish are in an appropriate vessel, the salinity is dropped rapidly down to 1 ppt (within half an hour) for 1.5h and then increased back to 35 ppt. It is critical that the salinity be measured accurately, as there is a small margin between the lethal salinity for the parasites and the fish. Oxygen is supplied throughout the treatment. Town water filtered with a charcoal filter (to remove chlorine) is suitable for the freshwater bath. During summer, the Fremantle town water can get very warm (up to 30°C). Therefore prophylactic treatments are usually administered in spring and autumn, thereby avoiding summer. In summer, water must be cooled to a temperature close to that of culture water prior to use. At the ADU a tub is filled with water (combination of fresh and saltwater) and ice to give a salinity of 10ppt at a similar temperature to the tank. The lightly anaesthetised fish are then added to this brackish-water bath. Once the fish have recovered from the sedative effect of the anaesthetic, more filtered freshwater is added to the tub to reduce the salinity to the required 1 ppt.

During the treatment most fish lose buoyancy and become lighter or darker in colour. Fish must be monitored carefully, especially in the last thirty minutes, and treatment terminated if the fish become stressed (evidenced by erratic, rapid swimming).

At the conclusion of the treatment, the fish are anaesthetised lightly again (ensuring that salinity is back up to full strength seawater) and transferred to the broodstock tank which is now clean and refilled.

### *Caligus*

Several undescribed species of *Caligus* are common on wild dhufish and captive dhufish can become heavily infested (Pironet and Jones 2000). Although heavy infestations were uncommon, they caused considerable irritation to the fish, resulting in cessation of feeding and the appearance of skin ulcers, often on the head. Outbreaks were often associated with increasing water temperature. A freshwater bath of less than 90 minute duration effectively removed parasites, which could be seen floating on the surface of the treatment container.

### *Bacteria*

Bacterial infections are common in captive dhufish. A number of species have been identified including *Vibrio* spp. (*V. parahaemolyticus*, *V. harveyi*, *V. alginolyticus*, *V. fluvialis* and other unidentified species; Pironet and Jones, 2000), *Photobacterium* spp (*P. damsela damsela*; Pironet and Jones, 2000) and *Flexibacter marinarum*. Few antibiotic treatments have been trialed on dhufish, however oxytetracycline has been found to be a safe and effective antibiotic. It is normally administered as a water bath at 100 ppm for 2hrs for ten successive days.

### *Fungi*

Fungi were occasionally observed in captive dhufish. *Exophiala* sp ("black yeast") was the most problematic and affected one tank of one year old hatchery reared dhufish (Stephens 2001). Affected dhufish had brown/black skin lesions and fungal hyphae within granulomata in internal organs such as the liver and kidney. Mortality was very high but ceased several weeks after the commencement of a series of 75ppm formalin/malachite green baths.

### *Cryptocaryon irritans (white spot)*

Only one outbreak of this protozoan pathogen has been identified over the duration of the project. It occurred in fish recently caught from the wild. After initially feeding well, the fish ceased feeding 8 days after capture and later developed vertical stripe-like haemorrhagic lesions across the flanks of the affected fish (Pironet and Jones, 2000). One affected fish died, however, after treatment with formalin/malachite green (2 treatments 5 days apart) the five remaining affected fish recovered slowly.

### *Aega cyclops*

Although common in the nostrils of wild-caught fish, these isopods were not observed in captive fish following treatment with freshwater baths during quarantine (Pironet and Jones, 2000).

### *Philometra lateolabracis*

The nematode parasite *Philometra lateolabracis* is common in the ovaries and testes of dhufish in the wild (Hesp, Hobbs et al. 2002). Although most captive dhufish examined had firm fibrous and necrotic masses (evidence of previous infection) active *Philometra* has not been detected in fish that have been in captivity for more than one spawning season. This is most likely due to the absence of a secondary host in the culture environment. The persistence of the necrotic mass in the gonads for several years following the last active infection was, however, a problem for the culture program. In most cases the necrotic mass was at the posterior end of the oviduct and in several cases caused difficulties in conducting ovarian biopsies and in stripping eggs. The effect on spawning fish is unknown, however, it is possible that the necrotic mass may impede the release of eggs from the oviduct. No treatment to break down the granuloma has been developed.

### *Miscellaneous parasites*

An unidentified species of *Argulus* was found on the skin of two wild-caught dhufish. *Sanguinicola* sp. was found in the heart of one wild-caught dhufish and unidentified, live larval nematodes were frequently present in the stomach wall and peritoneal cavity of wild-caught dhufish (Stephens 2001).

### 8.3.2 Non-infectious diseases

#### *Exophthalmos*

Exophthalmos is a common condition amongst captive dhufish and in a variety of other cultured fish species worldwide. The problem is easily identified by abnormal swelling of the eyeball. Initially it was thought that exophthalmos was induced by trauma to the eye resulting in haemorrhage (eg during handling or if the fish strikes the side of the tank when startled) (Pironet and Jones 2000). However, the presence of large gas bubbles within haemorrhage in the choroidal layer of affected eyes, suggested a more complex pathogenesis.

The oxygen tension at the retinal-vitreous junction of normal dhufish eyes was approximately double that of culture water. Gas in bubbles within eyes of fish with recent exophthalmos contained up to 73% oxygen (Stephens, Cleary et al. 2001). It is probable that the single haemoglobin of dhufish, with its marked sensitivity to pH (the Root effect), may predispose the fish to exophthalmos (Stephens, Cleary et al. 2002). Although the retinal-vitreous junction of normal eyes of snapper, *Pagrus auratus*, was supersaturated with oxygen, snapper were not as susceptible to developing exophthalmos (Stephens 2001). Snapper and several other species that were examined had multiple haemoglobin isomorphs and a Root effect of lesser magnitude than dhufish.

It is now considered more likely that environmental stress (eg high temperatures) and/or rapid and prolonged swimming initiates a series of physiological events resulting in decreased solubility of oxygen within the supersaturated eye and/or increased gas secretion into the eye. To reduce the occurrence of exophthalmos it is recommended that peaks of high temperature, sudden noises, rapid movement and changes in light intensity be avoided as these may increase the likelihood of the condition. Holding dhufish in deep water is also likely to reduce the prevalence of exophthalmos by reducing the level of supersaturation of oxygen within the choroidal layer of the eye.

There is currently no treatment for exophthalmos, except removal of the eyeball. This is a relatively simple procedure and can be done under anaesthesia. Although fish with a removed eye resume feeding shortly after the excision, they do not thrive. Many fish "recover" from exophthalmos, however, their eyes may remain permanently damaged. This represents a potentially serious loss of economic value as such fish are unlikely to be suitable for sale as whole fish.

#### *"Fatty liver" syndrome*

"Fatty liver" syndrome has been identified in hatchery-reared dhufish from pre-wean onward. Although this condition is common in many aquaculture species, the severity of the condition



was extreme in juvenile dhufish spawned in one season. Multiple granulomas occurred in the liver of some fish, and these contained acicular clefts (Stephens 2001). The condition was thought to be of undefined nutritional origin. Affected fish had reduced growth rate, and feed conversion efficiency. In addition, most groups of affected fish suffered repeated outbreaks of various diseases including gill-fluke, *Exophiala* and bacterial branchitis and septicaemia. These are suspected to be a secondary result of the underlying nutritional disease.

## References

Hesp, S. A., R. P. Hobbs, et al. (2002). "Infection of the gonads of *Glaucosoma hebraicum* by the nematode *Philometra lateolabracis*: occurrence and host response." Journal of Fish Biology **60**(3): 663-673.

Kritsky, D. C. and F. J. Stephens (2001). "*Haliotrema abaddon* n. sp. (Monogenoidea:Dactylogyridae) from the gills of wild and maricultured West Australian dhufish *Glaucosoma hebraicum* (Teleostei:Glaucosomatidae), in Australia." Journal of Parasitology **87**(4): 749-754.

Pickering, A. D. (1998). Stress responses of farmed fish. Biology of farmed fish. K. D. Black and A. D. Pickering. Sheffield, Sheffield Academic Press: 222-255.

Pironet, F. N. and J. B. Jones (2000). "Treatments for ectoparasites and diseases in captive Western Australian dhufish." Aquaculture International **8**(4): 349-361.

Stephens, F. J. (2001). Health problems of the West Australian dhufish. School of Veterinary Biology and Biomedical Science. Perth, Murdoch University: 211.

Stephens, F. J., J. J. Cleary, et al. (2001). "Pathogenesis and epidemiology of spontaneous exophthalmos in the West Australian dhufish, *Glaucosoma hebraicum* Richardson, 1845." Journal of Fish Diseases **24**(9): 515-522.

Stephens, F. J., J. J. Cleary, et al. (2002). "Haemoglobin and oxygen transport: a possible role in gas bubble formation in the eye of the West Australian dhufish, *Glaucosoma hebraicum* and other species." Journal of Fish Diseases **25**: 409-414.

Stephens, F. J., J. J. Cleary, et al. (2003). "Treatments to control *Haliotrema abaddon* in the West Australian dhufish, *Glaucosoma hebraicum*." Aquaculture **215**(1-4): 1-10.

#### 8.4 Non-technical summary of FRDC Final Report 98/328 Health Problems of Western Australian Dhufish

OUTCOMES ACHIEVED: Captive dhufish are very susceptible to multiple health problems that result in ill thrift or death. Successful aquaculture of dhufish requires the maintenance of robust fish by the provision of an environment that is optimal for the species. The provision of suitable stocking density, physico-chemical characteristics of water and diet appear to be key components of a management strategy to reduce dhufish health problems.

The purpose of this project was to describe and investigate health problems in captive West Australian dhufish, *Glaucosoma hebraicum*. The dhufish is a potential aquaculture species due to its popularity as an edible species and fishing pressure on wild fisheries. The two most significant health problems apparent in captive dhufish were exophthalmos in otherwise apparently normal fish and infestation of gills with a monogenean parasite, *Haliotrema abaddon*. Several other health problems were also described and investigated during the project.

Exophthalmic lesions were described, followed by investigations into the aetiology and pathogenesis of the condition. Epidemiological data were gathered to identify risk factors that may increase the pre-disposition of dhufish to the development of exophthalmos. The anatomical arrangement of vasculature supplying the eye was described and the haemoglobin-oxygen transport properties of dhufish blood that pre-dispose dhufish to exophthalmos were studied. Oxygen partial pressure in the normal retina and oxygen content of gas bubbles in exophthalmic eyes were recorded. Risk factors for the development of exophthalmos were investigated in an experiment using unaffected fish, variable water temperature, fright-induction and exercise regimes.

Gas and haemorrhage was present in the choroid of exophthalmic eyes, with haemorrhage in retrobulbar tissues resulting from perforation of the sclera in some eyes. Oxygen content of gas in eyes with recently developed exophthalmos was high (up to 73%). In some eyes with retrobulbar haemorrhage, oxygen tension approached zero, indicating severe disruption of blood supply to the eye. Oxygen tension at the retinal-vitreous junction of normal dhufish eyes was high ( $344 \pm 26$  mm Hg), with oxygenated blood supplied to the choroid body from the gills via the pseudobranch. The finding of a single haemoglobin with pronounced Root and Bohr effects in dhufish was significant and may contribute to the susceptibility of the species to exophthalmos.

Investigations suggest that exophthalmos is physiological in origin and is related to the environmental differences between the natural habitat of the fish and the conditions that are experienced in aquaculture. Dhufish appear to be highly adapted to a relatively inactive life-style with relatively constant environmental conditions at high hydrostatic pressure. Rapid changes of temperature or blood acid-base characteristics may precipitate the development of exophthalmos.

The monogenean parasite, *Haliotrema abaddon*, was described and stages of its life-cycle identified. As the parasite was troublesome in captive fish, potential treatments were investigated using *in vitro* and *in vivo* studies. Praziquantel was identified as the most effective 'in water' treatment of fish infested with *H. abaddon*. Other useful but less effective and safe treatments were low salinity baths (<1.5 ppt for ninety minutes) and  $0.5 \text{ mg L}^{-1}$  trichlorphon for 36 hours.

Life in tanks appears stressful for many dhufish, resulting in health problems such as exophthalmos and disease outbreaks, including severe *H. abaddon* infestation and bacterial and fungal diseases. Multiple risk factors appear to pre-dispose the fish to these conditions. They include environmental factors such as water temperature, depth and physico-chemical composition, diet and stocking density; host factors such as physiological and social adaptation to a relatively solitary, sedentary lifestyle in a deep-water habitat and pathogen factors such as increased fecundity and decreased generation time in warmer water temperatures. Decreasing fish stress and maintaining environmental conditions close to those in the natural habitat, including increasing tank depth and decreasing light intensity are expected to improve the overall health of captive dhufish.

**Keywords:** dhufish, *Glaucosoma hebraicum*, health, exophthalmos, parasite, Monogenea, aquaculture.

## Chapter 9: References

- Barnetson, I. (unpub). Market Potential for WA Dhufish (*Glaucosoma hebraicum*). Independent report prepared for the Aquaculture Development Unit, South Metro TAFE. 20pp
- Cleary, J.J. (1997). The effect of stress on reproduction in snapper, *Pagrus auratus*. Thesis. Department of Aquaculture, University of Tasmania, Australia.
- Cleary, J., Jenkins, G., and Pankhurst, N., (1999). Slow Release LHRHa Pellet Stimulates Spermiation and Ovulation in Westralian Dhufish (*Glaucosoma hebraicum*). Proceedings of World Aquaculture Society Conference, 26 April - 2 May 1999, Sydney, Australia.
- Glencross, B.D., Van Barnveld, R.J., Carter, C.G. and Clarke, S.M. (1999). On the path to a manufactured feed for farmed Southern Bluefin Tuna. World Aquaculture Society Journal 30: 42-46
- Glencross, B.D., Curnow, J., Aris, A. and Cleary, J. (2000). Evaluation of feed ingredient utilisation and native tissue composition as a precursor to diet development for the West Australian Dhufish (*Glaucosoma hebraicum*). Aquaculture in review
- Hesp, S.A. and Potter, I.C. 1999. Determination of the biological parameters required for managing the fishery of West Australian dhufish. Fisheries research and Development Corporation Project 96/103 Final Report 31 pp
- Hobby, A. and Pankhurst, N.W. (1997). Post-ovulatory egg viability in the snapper *Pagrus auratus* (Sparidae). Marine and Freshwater Research 48:385-9
- Hutchins, B. and Swainston, S. (1986). Sea Fishes of Southern Australia. Complete Field Guide for Anglers and Divers. Swainston Publishing Perth p 52-53
- Jenkins, G.I., Frankish, K.R. and Partridge, G.J. 1999. Manual for the Hatchery Production of Black Bream (*Acanthopagrus butcheri*). Information Series 1999/1 Aquaculture Development Unit, South Metropolitan TAFE. 125pp
- Lavens, P., Sorgeloos, P., Dhert, P. and Devresse, B. (1995). Larval Foods. In: Bromage, N. and Roberts, R.J. (eds), Broodstock Management and Egg and Larval Quality. Blackwell Science, Oxford. pp 373-397.
- Lee, C. S., Tamaru, C.S. and Kelley, C.D. (1986). Technique for making chronic-release LHRH-a and 17 $\alpha$ -methyltestosterone pellets for intramuscular implantation in fishes. Aquaculture 59: 161-168

- McKay, R. J., 1997. Pearl perch of the world. (Family Glaucosomatidae). An annotated and illustrated catalogue of the pearl perches known to date. FAO species catalogue. FAO Fisheries Synopsis. 125(17). Food and Agriculture Organization of the United Nations, Rome, 26 pp.
- Palmer, P.J., Burke, J.B., Willet, D.J. and Simpson, R.R. (1992). Development of a low-maintenance technique for rearing barramundi (*Bloch*) larvae. Queensland Department of Primary Industries, Information Series, No. Q192036
- Pankhurst, N.W. 1998. Reproduction. Pages 1-26 *in*. K. Black and A.D. Pickering editors. Biology of Farmed Fish. Sheffield Academic Press, Sheffield.
- Partridge, G.J., Ginbey, B., Kennerly, D.V. and Frankish, K. 1998. A comparison of semi-intensive larviculture techniques. Information Series 1998/1 Aquaculture Development Unit, South Metropolitan TAFE. 28pp
- Payne, M., Rippingale, R.J. and Cleary, J.J (2000). Cultured copepods as food for West Australian dhufish (*Glaucosoma hebraicum*) and pink snapper (*Pagrus auratus*) larvae. Aquaculture in press Pearce, A.F. (1991). Eastern boundary currents of the southern hemisphere. Journal of the Royal Society of Western Australia. 74: 35-45
- Pironet, F. N. and Jones, J. B., (in preparation). Treatment of parasites and diseases of captive Western Australian dhufish (*Glaucosoma hebraicum* Richardson). Fremantle Maritime Centre, Fremantle, Western Australia, 25 pp.
- Pironet, F.N and Neira, F.J. 1998. Hormone induced spawning and development of artificially reared larvae of the West Australian dhufish, *Glaucosoma hebraicum* (Glaucosomatidae). Marine and Freshwater Research 49: 133-42
- Rippingale, R. and Payne, M. (1999). Intensive cultivation of a calanoid copepod for live food in fish culture. Project 99/398 Final Report
- Robinson, R. G., 1987. The Morphology and Histology of the Ailmentary Tract: the Dietary Preference of the Western Australian Jewfish; *Glaucosoma hebraicum*. School of Biology, Curtin University of Technology. Third Year Student Report, 46 pp.
- Sudemeyer, J.E., Hancock, D.A., Lenanton, R.C.J. (1990). Biological synopsis of Westralian jewfish (*Glaucosoma hebraicum*) (Richardson, 1845)(Pisces: Glaucosomatidae). Fisheries Department of Western Australia. Report No. 96/97. Fisheries Research Report. Fisheries Western Australia.
- Thorn, T.J. 1995. Fish Health for Fish Farmers in Western Australia. Fisheries Department of Western Australia.

## Appendices

### **Appendix A    *Decompression sickness in Western Australian dhufish (*Glaucosoma hebraicum*)***

Author: Damien Ashby

This dissertation was presented as a partial fulfilment of the conditions for the degree of Bachelor of Science in Natural Resource Management. Faculty of Agriculture, University of Western Australia. November 1996. The project was funded by the Recreational Fishing and Advisory Committee. The work is unpublished and so is presented here in its entirety to make it more readily available to interested parties.

#### **Abstract**

The Westralian Dhufish (*Glaucosoma hebraicum*) is a highly sought after recreational and commercial fishing species in Western Australia. Current management of the Westralian Dhufish involves a bag limit and the releasing of undersized fish. However, the returning of undersized fish will be of no service to the conservation of the fishery if the fish die from the effects of the depressurisation during capture. This report describes an experiment to test the hypotheses that upon capture, Westralian Dhufish sustain damage caused by decompression sickness and that the damage sustained increases with increasing depth.

30 fish were caught from two depth categories. 15 fish were caught in water less than 20 metres (shallow category) and 15 in water deeper than 20 metres (deep category). Gross pathology examination was performed immediately after capture and samples of the heart, liver, kidney and spleen were removed for histopathology examination back in the laboratory. Acute damage was assessed based on the degree of bubble formation, clotting and haemorrhaging (symptoms of decompression sickness) in the various tissues.

Bubbles, clotting and haemorrhaging were found in all fish from both depth categories. Bubbles were often occluding blood vessels and several empty and broken blood vessels were noted. Exophthalmia and rupture of the swim bladder occurred in some of the deep-water fish. The mean damage scores for the deep-water fish were all higher than the scores for the shallow water fish. In conclusion, both hypotheses were supported in that all fish sustain damage from decompression sickness upon capture and the damage for deep-water fish is greater than the damage for shallow water fish.

Further research is required to determine the long-term survival of Westralian Dhufish after being caught and released.

## **Acknowledgments**

Firstly, I must thank my supervisor, Dr Roberta Bencini, for her patience and guidance through the course of this study.

Secondly, I wish to thank my co-supervisor, Dr Brian Jones at Agriculture Western Australia who helped me set up the project and guided me through the results and analysis. His knowledge and assistance has been invaluable to the smooth running of this project. I also thank the staff at Agriculture Western Australia who made the histopathology slides.

Thankyou to Franz Van der Poll for taking me fishing and for assisting me with the examination of the fish. I also thank Franz and his wife Mary for their hospitality while I was up at Ledge Point.

I would also like to thank Greg Jenkins and the Fremantle Maritime Centre for setting up this project and helping me organise the fishing.

Thankyou to the Recreational Fishing Advisory Committee for funding this project. I hope you are pleased with the results.

Thankyou to John Beasley and the Animal Science group for assisting me with transport, cameras and film.

Finally, I must thank my family and friends, especially Jessica Patterson, for supporting me and putting up with my stress.

## 1. Introduction

The Westralian Dhufish (*Glaucosoma hebraicum*) is a native to Western Australia and is one of the most sought after commercial and recreational fishing species (Figure A3). Their distribution ranges from as far south as Esperence and north to Shark Bay. They inhabit deep reefs usually in waters greater than 30 metres (Fisheries dept. WA 1993). They move into shallower water twice a year in March and again in September (F.Van der Pol, Ledge Point, WA, pers comm 1996) and can be caught in as little as 5 metres. WA Dhufish are slow growing, reaching sexual maturity at four to five years of age (Fisheries dept. WA 1993). They can grow to sizes greater than 25 kg.

The increasing numbers of amateur boats licensed each year combined with the advances in fishing technology have dramatically increased the pressure on this species. Good management is required to ensure we do not place the future of this species in jeopardy. Current management of the WA Dhufish is based on a bag limit (4 per day) for amateur fishermen and on the release of undersized fish (minimum legal size - 50cm), which applies for all fishermen. However, this management can only be effective if fish that are released survive. The returning of undersized Dhufish will be of no service to the conservation of the fishery if the fish die from the effects of capture and handling.

The Aquaculture Development Unit is currently researching into the spawning and culture of the Westralian Dhufish. In the time they have been collecting fish from the wild for broodstock, a general trend has been observed that fish caught in over 20 metres of water do not survive back in the hatchery tanks. They either die shortly after capture or within a few days or weeks after relocation to the hatchery. Fish caught under 20 metres adapt well to the change and survive in the hatchery (G. Jenkins, Aquaculture Development Unit, South Metropolitan TAFE, pers comm 1996).

It is common knowledge within the fishing industry that considerable damage is sustained by fish caught from great depth. Common damage seen includes protrusion of the eyes, over-inflation and often bursting of the swim bladder, inversion of the stomach out of the mouth and displacement of internal organs through the anus. Haemorrhaging and gas bubbles are often seen throughout the organs of the fish. Assuming that the fish is in good health before being caught, significant damage and mortalities could be due to the rapid depressurisation from depth. The physics of inert gas bubble formation upon rapid and extensive reduction in barometric pressure apply to all living things. The effects on Dhufish would be analogous to those seen in decompression sickness in divers. This report describes an experiment to test the hypotheses that upon capture, Westralian Dhufish sustain damage caused by decompression sickness and that damage sustained by Westralian Dhufish increases with increasing depth.

## 2. Literature Review

### 2.1. *The Solubility of Gases in the Ocean*

All of the atmospheric gases are found in solution in sea-water (Sverdrup *et al* 1942). The concentration of these dissolved gases depends on the partial pressure of that gas in the atmosphere and its solubility (Henry's law). Solubility increases with molecular weight and decreases with increasing temperature and salinity.

In studies of the distribution of dissolved gases in the sea it is generally assumed that whatever the location of a water particle, at some time it has been at the surface and in equilibrium with the atmosphere. So when we examine deep sea water we would expect the gas content, except for oxygen and carbon dioxide, to be the same as the expected gas content at the surface. Oxygen and carbon dioxide concentrations would be different as they are consumed biologically. In studies of dissolved nitrogen (N<sub>2</sub>), it has been found that sea water is virtually saturated (referred to a normal atmosphere) regardless of depth, making this assumption valid (Rakestraw & Emmel 1937, Broecker 1974, Shilling *et al* 1976, Saunders 1953). This also indicates that biological activity involving either fixation or production of N<sub>2</sub> is not sufficient to affect significantly the concentration of this gas in the water (Rakestraw & Emmel 1937).

Depending on the temperature of the surface water and with a normal ocean salinity of 35 parts per thousand (ppt), the concentration of dissolved nitrogen normally ranges between 8.4 and 14.5 ppt (Sverdrup *et al* 1942). Nitrogen is present at a partial pressure of 0.79 atm at all depths in ocean water in all but exceptional circumstances (Saunders 1953, Shilling *et al* 1976). Nitrogen represents the major inert gas in sea water, with other inert gases (Argon, helium, etc.) combining to equal only 2.7% of the dissolved nitrogen (Harvey 1955).

### 2.2. *The Physics of the Ocean and Gases.*

Gases are highly compressible due to the random free nature of their particles. The pressure of a given volume of gas, where temperature remains unchanged, varies inversely to its volume according to Boyle's law:

$$PV = K \quad \text{where} \quad \begin{array}{l} P = \text{pressure} \\ V = \text{volume} \\ K = \text{constant} \end{array}$$

If the pressure of a given amount of gas is doubled, it must be compressed to half its volume. A balloon filled with a given amount of gas can be used to illustrate the effects of increasing pressure in the underwater environment (Figure A1). At the ocean surface the balloon is subjected to the atmospheric pressure at sea level. This is the pressure of air directly above the balloon taken to be 760mm Hg or 1 atmosphere (1atm), disregarding any daily fluctuations. Pressure increases by



1atm every 10 metres of water (Shilling *et al* 1976). Thus, when the balloon is at 10 metres in depth it is under 2atm of pressure. The doubling of the pressure at 10 metres means the balloon contracts to half its original volume. At 20 metres in depth the balloon is under a pressure of 3atm which causes the balloon to decrease to a third of its original volume at the surface and so on.

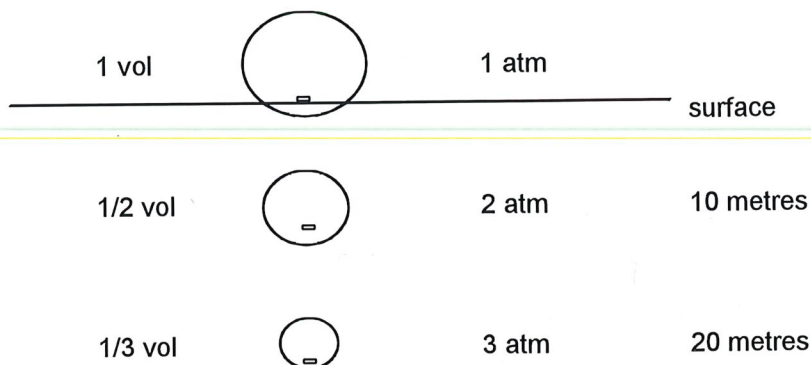

**Figure A1:** The effects on the volume of a balloon as pressure increases with depth (according to Boyle's Law).

The balloon can be taken as representing the air in the lungs of a diver. However, the lungs of a diver would crush under the increasing ambient water pressure. The air inside the lungs must be kept at a constant volume with increasing ambient pressure. To keep a constant volume, the air inside the lungs must be kept at the same pressure as the ambient water pressure. This is achieved by pumping more air into the lungs as the diver moves deeper and is subjected to increasing pressure. This is illustrated in Figure A2 using the balloon example again. At 10 metres, 2atm of gas would need to be supplied to the balloon to keep its volume the same as it was at the surface, while at 20 metres, 3atm of gas would be required. The extra air required by the diver can be supplied from a source of compressed air at the surface or from gas cylinders carried by the diver (Shilling *et al* 1976).

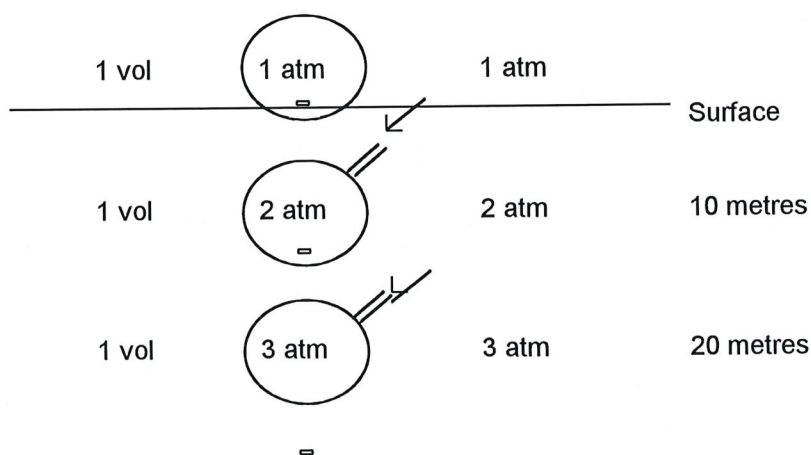

**Figure A2:** To maintain a constant volume in the balloon, gas has to be pumped into it as pressure increases with depth.

The balloon can also represent the swim bladder in a fish which must be kept at a constant volume to maintain neutral buoyancy. This is achieved by the secretion of gas in and out of the swim bladder as the ambient pressure changes. As a fish moves deeper, gas is secreted into the gas bladder from the bloodstream and when the fish moves up the water column, gas is absorbed back into the blood from the bladder.

### 2.3. Decompression Sickness in Humans

Decompression sickness, also referred to as the bends, caisson disease (in reference to tunnel workers), compressed air illness or dysbarism is a syndrome associated with a rapid and extensive reduction in environmental barometric pressure (Philp 1974). Not only has it been encountered by deep sea divers, but also by high altitude aviators and men employed in underground engineering projects in which compressed air is used to hold back ground water. It is also a potential hazard for astronauts and commercial airline passengers, should there be an accidental loss of cabin pressure (Philp 1974).

As the pressure of air increases inside the lungs of a diver to match the ambient water pressure, there is an increase in the partial pressures of the individual gas components of the air mixture being breathed in. Excluding CO<sub>2</sub> and other trace elements, air is made up of a mixture of the gases Nitrogen (79%) and Oxygen (21%) (Shilling *et al* 1976). Normal atmospheric pressure at sea level is 1atm or 760mm Hg. Thus the partial pressures of nitrogen (N<sub>2</sub>) and oxygen (O<sub>2</sub>) are:

$$P (N_2) = 79\% \text{ of } 760\text{mm Hg} = 600\text{mm Hg or } 0.79\text{atm}$$

$$P (O_2) = 21\% \text{ of } 760\text{mm Hg} = 160\text{mm Hg or } 0.21\text{atm}$$

As the diver descends, the pressure of air being supplied to the lungs increases resulting in a corresponding increase in the partial pressures of N<sub>2</sub> and O<sub>2</sub>. At 10 metres the partial pressures of these gases doubles (1.58 atm and 0.42 atm respectively). The increase in partial pressures of these gases has several physiological implications for the diver. Problems can arise such as oxygen toxicity, nitrogen narcosis (a manifestation of general anaesthesia), high-pressure neurological syndrome (the symptoms caused by pressure alone) and decompression sickness (Smith 1984). It is the absorption of increasing amounts of nitrogen with increasing water pressure that leads to decompression sickness in humans. The focus of this study is on decompression sickness (also known as 'the bends') which is caused by the formation of inert nitrogen gas bubbles in the blood and tissues as a result of a sudden lowering of the ambient pressure. Nitrogen gas is chemically inert in that it is not significantly affected by biological processes (Sverdrup *et al* 1942). Oxygen gas does not cause decompression sickness unless at very high pressures as it is consumed biologically in metabolism and is bound and transported by haemoglobin (Beyer *et al* 1976, Shilling *et al* 1976). Other inert gases such as argon, neon and helium can play a role in decompression sickness, however, these gases are present in only minute quantities even at high partial pressures.

Study of decompression sickness has not advanced very far during this century. The early theories of Haldane and his associates (Boycott *et al* 1908) are still used today for the modelling of decompression schedules. Haldane postulated that during diving the body absorbs the excess nitrogen supplied to the lungs as a result of the increase in pressure and that this is the gas responsible for bubble formation during decompression (Boycott *et al* 1908). This nitrogen is distributed through the body via the blood. Nitrogen is absorbed by the various body tissues according to their relative solubility and the blood supply to that tissue (Shilling *et al* 1976). All the inert gases dissolve in blood and tissue according to Henry's law:

$$C_x = a_x P_x \quad \text{where}$$

$C$  = dissolved concentration [ $\text{cm}^3$  (STP)/ $\text{cm}^3$  fluid]  
 $a$  = absorption constant [ $\text{cm}^3$  (STP)/ $\text{cm}^3$  fluid atm]  
 $P$  = partial pressure [atm]  
 $x$  = inert gas

When a diver is exposed to an increased partial pressure of nitrogen, the body absorbs the excess gas through the lungs and into the bloodstream. Nitrogen dissolves into the body tissue and fluids and with time the dissolved concentration will reach equilibrium with the pressure in the lungs (Shilling *et al* 1976). After equilibrium is reached, no more gas dissolves. Thus if divers stay at a certain depth for long enough, they will absorb nitrogen to saturation. After this point is reached, there is no further decompression liability.

The solubility of inert gases is greater in fat tissue than in lean tissue as these gases have a greater affinity for lipoidal fluids (Shilling *et al* 1976). The relative solubility of nitrogen in different fluids can be seen in Table A1. Thus, fat tissue represents a large reservoir for dissolved nitrogen. Increasing age and body weight increases susceptibility to decompression sickness (Shilling *et al* 1976).

**Table A1 Solubility coefficients for Nitrogen gas in biological fluids at 37°C (Shilling *et al* 1976).**

	Blood	Lean Tissue	Fat Tissue	Olive Oil
<b>Solubility of N<sub>2</sub></b>	0.013	0.012	0.062	0.067

At equilibrium the dissolved N<sub>2</sub> is at a maximum and the body tissues are considered saturated. A decrease in absolute pressure results in a decrease in the maximum N<sub>2</sub> that can be dissolved in tissue according to Henry's law. The tissues become supersaturated and nitrogen must be removed to re-establish equilibrium. If the decompression is slow, the excess nitrogen can be removed through the blood to the lungs for exhalation (Shilling *et al* 1976). Rapid decompression

saturates the rate of nitrogen elimination leading to the dissolution of nitrogen from the blood and tissues. The nitrogen leaves solution into bubbles until the concentration of dissolved nitrogen re-establishes equilibrium with the reduced partial pressure in the lungs. This situation is analogous to the precipitation of solute from a supersaturated solution and is frequently compared to the formation of bubbles associated with the opening of a soft drink bottle. The formation of intravascular bubbles obstructs the blood stream slowing the blood flow to the lungs, further reducing the rate of nitrogen elimination (Mitchell 1995).

The earliest bubbles are intravascular with the number of bubbles and sites of formation dependant on the magnitude of the decompression (Daniels 1984). However, Smith (1984) found that the severity of bubble formation is only moderately receptive to pressure change and that even in the most severe decompressions the level of bubble formation appears to reach a limiting value. It is the accumulation of stationary bubbles in the bloodstream and tissues that lead to the symptoms of decompression sickness (Daniels 1984). There is a critical end point in the amount of nitrogen bubbles released, which if passed, leads to the symptoms of decompression sickness (Hills 1970, Buckles 1968). Thus, even in 'safe' dives there is still some bubble release, known as 'silent bubbles'. The incidence of decompression sickness with multiple dives is due to the accumulation of these 'silent bubbles'.

### The Effect of Bubbles

Several haematological changes are associated with bubble formation in the blood due to the highly active gas-blood interface. Bubble pressure can lead to protein denaturation, similar to that caused by increased temperature (Smith 1984). Extravascular bubbles can rupture cell membranes releasing cell enzymes and lipids into the vascular system. Studies have shown that significant elevations in certain enzymes are indicative of tissue trauma and can be measured to gauge the extent of damage (Shilling *et al* 1976). The increase in circulating lipids leads to massive amounts of fat embolism, especially in the pulmonary capillaries and arterioles (Clay 1963). Intravascular bubbles can lead to air embolisation, blocking the flow of blood resulting in anoxic injury to the tissues (Shilling *et al* 1976, Weitkamp & Katz 1980). If bubble pressure is great enough, the vessel can rupture resulting in the haemorrhaging of blood into body tissue and the formation of clots at the damaged site (Thomson 1967, Kulshrestha & Mandal 1982). With increasing bubble formation, there is an associated increase in haemorrhaging and clotting.

#### 2.4. *Decompression Sickness in Fish*

Decompression sickness in man is a result of basic physics which apply to all things in nature. It is reasonable to say that the effects of decompression would be similar to all living organisms. The capture of a fish involves a rapid retrieval from depth and is generally associated with a huge pressure reduction. The effects of a rapid decompression in a fish would be analogous to those found in man. The swim bladder in a fish is similar to the lungs of a diver in structure, however, its

function is to keep the fish neutrally buoyant. When a diver ascends from depth, the expanding gas in the lungs from the reduction in pressure (according to Boyle's Law), can be easily expelled through exhalation. Some fish, known as physostomes have a swim bladder that is connected by an pneumatic duct to the gut which allows the fish to expel gas directly from the swim bladder upon pressure reduction (Saunders 1953, Ferguson 1989). Westralian Dhufish are physoclists, which have a closed swim bladder, lacking a pneumatic duct (Saunders 1953). There is a well-developed capillary mesh that supplies blood to the swimbladder (Ferguson 1989) and this is the means by which gas enters and leaves the swimbladder. Therefore, upon pressure reduction, the expanding gas in the swim bladder must be removed via the bloodstream (Saunders 1953). If the pressure reduction is rapid, the gas entering the bloodstream is under pressure and the blood quickly becomes supersaturated. This leads to the formation of bubbles in the blood and the effects of decompression sickness. At the same time, dissolved nitrogen in the body tissues is coming out of solution and forming more bubbles, compounding the damage. Fish are subjected to both forms of bubble formation, while divers are only subjected to the formation of bubbles from dissolved nitrogen in the body, as they can expel expanding air in their lungs.

The expansion of gas according to Boyle's Law, is enhanced by an increase in temperature. The temperature in the first 100 metres of the ocean does not change to any appreciable extent ( $\sim 1^{\circ}\text{C}$ ) (Broecker 1974). However, the temperature of the air in summer (when most recreational fishing is done) would be higher than that of the water from which the fish was caught. This increase in temperature would enhance the expansion of the swim bladder and the formation of bubbles, making the damage worse.

D'Aoust and Smith (1974) suggested that fish might be more sensitive to decompression stress than higher vertebrates because of their poorly perfused white muscle. The diffusion limited nature of their white muscle means dissolved gas takes longer to be expelled from the body.

Few studies have been conducted on the effects of decompression on fish, most of them in the USA. Feathers & Knable (1983) studied the effects of rapid decompression upon Largemouth Bass (*Micropterus salmoides*). They simulated the depressurisation from depth using a hyperbaric chamber in which the fish were acclimatised to the pressure of a certain depth and then subjected to rapid decompression which simulated conditions common to deep water angling. Fish depressurised from all depths experienced some bloating and external haemorrhaging. Fish decompressed from depths over 18.3 metres experienced severe internal haemorrhaging and formation of gas bubbles in the blood. These fish, subsequently had high mortality (at least 40%) as a result of decompression alone. The percentage of total mortality was directly related with the magnitude of decompression.

The damage found by Feathers and Knable (1983) included haemorrhaging in small blood vessels of the peritoneum, swim bladder, digestive tract, kidneys and those extending from the dorsal aorta. Large gas bubbles were found in the cardinal and hepatic veins, heart, gills and brain. While some bubbles could be tolerated, large gas bubbles in vital areas such as the heart were major

contributors to mortality. Fish depressurised from shallower depths exhibited bubbles, but not enough to cause significant mortality. These results agree with the observations made at the Fremantle Maritime College (G. Jenkins, Aquaculture Development Unit, South Metropolitan TAFE, 1996) in their collections of broodstock.

Beyer *et al* (1976) studied the effects of decompression induced bubble formation in salmonoids. They found that as the severity of the decompression increased, the number of bubbles found in the tissue increased. Post-mortem examination established that bubbles occluded blood vessels and were found throughout the heart. The coronary arteries were often completely occluded with bubbles, thus shutting off the blood supply to the heart. Blood vessels in the liver, kidney, brain, gonad and spleen also contained visible bubbles. If fish showed any signs of decompression sickness they rarely recovered.

Beyer *et al* (1976) also found that the time period between onset of signs of stress and death was considerably longer for large fish compared to small fish. Obvious bubbles were usually found in the fins, tail and lateral line in the small fish, but were generally lacking in the larger fish. They attributed this finding to the relationship between lethal bubble size and critical vessel size. Theoretically, similar ranges of bubble size would occur in both small and large fish. However, considering the embolic effects, bubbles of the same size would have a more severe effect on smaller fish due to their smaller vessel size, whereas larger bubbles or an accumulation of small bubbles would be required to cause ill effects in larger fish (Beyer *et al* 1976). This disagrees with the work by Feathers & Knable (1983) who found no significant difference in the damage between small and large fish. Considering that nitrogen is highly soluble in fat, one would expect to find a much larger reservoir of dissolved nitrogen in larger fish. The release of nitrogen could be expected to be proportional to the size of the fish. In studies of decompression sickness in man, increasing age and body weight increased the susceptibility to the disease (Shilling *et al* 1976). These findings also disagree with the observations made at the Fremantle Maritime College (G. Jenkins pers comm) that small fish have lower mortality and show a faster recovery from the capture.

Casillas *et al* (1975) investigated changes in haemostatic parameters in fish following rapid decompression. They found that decompression-induced intravascular bubbles caused mechanical damage to the tissue, which activated the haemostatic mechanism of the fish. This is also supported by the findings of Speare (1991). Coagulation or clotting occurs at the damaged site as a result. An activated coagulation system was found to enhance the pathogenesis of decompression sickness, often increasing the probability of death. More severe decompressions had higher levels of coagulation, increasing the rates of mortality.

### 2.5. Relationship to Gas Bubble Disease

Gas bubble disease (GBD) in fish is often compared to decompression sickness. They both involve the formation of gas bubbles by supersaturation of the body tissues with dissolved nitrogen. Activation of clotting mechanisms is evident in both diseases (Speare 1991). Intravascular bubble

formation and damage caused by bubbles to the tissue, including occlusion of vessels and anoxic injury are similar between the two diseases (Speare 1991). In GBD, the gradient of supersaturation is in the opposite direction to that of decompression sickness, in that supersaturated water gradually supersaturates the fish, whereas in decompression sickness, the body tissues absorb inert gas at the ambient hydrostatic pressure and then become supersaturated when the external pressure is decreased (D'Aoust and Smith 1974). The pathology of GBD differs in that it involves a condition of chronic exposure to low level super saturation (D'Aoust and Smith 1974), whereas, in decompression sickness, the pressure differences are greater and occur over a relatively shorter duration (Strauss 1979).

### **3. Materials and Methods**

#### *3.1. Experimental Procedure*

Thirty WA Dhufish were caught from a boat using hand lines, over a period of five weeks between August and September. The fish were caught between 5 and 50 kilometres off Ledge Point which is approximately 140 kilometres north of Perth. 15 fish were caught in water less than 20 metres (shallow category) and 15 in water deeper than 20 metres (deep category). The minimum depth of capture was 9 metres up to a maximum depth of 73 metres. As WA Dhufish are a bottom dwelling species, depth of capture was recorded using the depth of the sea floor reading on an echo sounder. The fish were hauled to the surface as quickly as possible to simulate ordinary fishing technique (fisherman want to get the fish on board as quickly as possible). Length (tip of mouth to tip of tail) and weight of each fish were recorded upon capture.

The fish were killed as soon as practical and within five minutes after capture using cervical dislocation (spiking through the brain) as the method of euthanasia. The fish were immediately necropsied aboard the boat for examination of gross pathology. A visual examination of the skin, eyes, fins, opercula and gills was conducted and a damage score awarded. Scoring was assigned based on grading the degree of haemorrhaging and/or bubble formation. A score of 0 was awarded for no sign of damage. A score of 1, 2 or 3 was awarded for light, moderate or severe damage respectively. The gut cavity was opened and the degree of haemorrhage and/or bubble formation assessed for the gut flaps, liver, spleen, heart, kidney and swim bladder. Scores were assigned as before. Swim bladder inflation was based on a score of 1, 2 or 3. If the gut cavity was firm but not swollen, a score of 1 was awarded. If the gut cavity was swollen, a score of 2 was awarded. If the cavity was soft and upon dissection a rupture (large tear near the posterior end of swim bladder) was seen in the swim bladder, a score of 3 was awarded. The presence of exophthalmia was also scored. A score of 1 was awarded for its presence and a score of 0 if it was absent.

Small samples (~ 5mm x 5mm x 5mm) of the liver, spleen, heart and kidney were cut out and fixed in 10% formalin-seawater solution. These samples were taken back to the laboratory for subsequent histopathology examination. The tissues were dehydrated in an alcohol series,

embedded in wax and sectioned at 3 microns using standard techniques. Sections were routinely stained with Haematoxylin and Eosin. Slides were examined with a light microscope at 4x and 10x magnification, looking for acute damage in the various tissues. Acute damage was distinguishable by limited response to damage by the tissue (eg. Granule formation, white blood cell accumulation). Damage that was assessed included the formation of bubbles, blood clotting and haemorrhaging.

The presence of bubbles inside vessels, in blood and the tissue itself was given a score from 0-3. If no bubbles were present a score of zero was awarded. The presence of small bubbles only (did not displace tissue to any degree) was awarded a score of 1. The presence of small bubbles with a small number of large bubbles (displace tissue) and/or partial occlusion of vessels by bubbles was awarded a score of 2. Many large bubbles and the complete occlusion of vessels with bubbles was awarded a score of 3.

Clotting was distinguishable by pink areas in the form of a fibrous protein matrix with small amounts of white blood cell accumulation. Haemorrhaging was identified by the presence of blood through the tissue with no form of vessel or wall separating them. A scoring system of 0-3 was also used to grade the degree of clotting and haemorrhaging. A score of 0 was awarded for no clotting or haemorrhaging. If the clotting or haemorrhaging was greater than 0% but less than 5% of the tissue, a score of 1 was awarded. If the clotting or haemorrhaging was between 5% and 10% of the tissue, a score of 2 was awarded. A score of 3 was awarded if the clotting or haemorrhaging covered more than 10% of the tissue.

The presence of other indicators of tissue damage were recorded such as oedema and vessel breakage's, however, these were not scored. Oedema was identified by the swelling of intercellular spaces with fluid from broken blood or lymph vessels.

### *3.2. Statistical Analysis*

The construction of box plots illustrated that the data was not normally distributed. Mann-Whitney U tests (Zar 1984) which test non-parametric data were employed to compare the two depth categories for the different parameters measured. All statistical tests were performed at the P = 0.05 level.

## **4. Results**

Haemorrhaging, clotting and bubbles were present in all of the fish studied in both the gross and histopathology examinations. The mean damage scores for the deep water fish were all higher than the mean scores for the shallow fish (except kidney clotting).

### *4.1. Gross Pathology*

After capture, all fish showed signs of bubble formation in the fins, opercula and gut flaps (Fig A4, Table A2). However, mean scores were quite low (mean score <1.5) and there was no significant



difference between depth categories. Large bubbles could be seen in the lining at the base of the gills in some of the fish from deep water.

**Table A2: Mean damage scores and standard errors for gross bubble formation in WA Dhufish upon capture from two depth categories. (Scores: 0-3)**

Depth Category	Fin bubbles	Opercula bubbles	Gut flap bubbles
Shallow (< 20m)	0.3 ± 0.11	0.2 ± 0.11	0.6 ± 0.15
Deep (> 20m)	0.3 ± 0.13	0.7 ± 0.24	1.4 ± 0.26
P-value	0.317	0.637	0.157

Haemorrhaging was evident in the liver (Figs A5 and A6), heart and swim bladder, especially for the deep water fish with mean scores of  $2.4 \pm 0.12$ ,  $1.5 \pm 0.32$  and  $1.7 \pm 0.28$  respectively (Table A3). The haemorrhage scores for the deep water fish were all significantly higher than the scores for the shallow water fish. Swim bladder haemorrhaging occurred in the network of capillaries on the inside lining of the swim bladder. The difference in haemorrhage severity between shallow and deep water fish is illustrated in Figures A7 and A8.

Gross haemorrhaging could not be distinguished in the kidney or spleen due to the dark colour of these organs. Evidence of bubbles was also difficult to distinguish in the organs of the fish. However, bubbles were present in the gut lining and in the residue blood on the surface of the organs. The presence of bubbles in these areas indicates that gas was escaping.

**Table A3: Mean damage scores and standard errors for gross haemorrhaging in WA Dhufish upon capture from two depth categories. (Scores: 0-3)**

Depth category	Liver haemorrhage	Heart haemorrhage	Swim Bladder haemorrhage
Shallow (< 20m)	0.7 ± 0.18	0.5 ± 0.17	0.3 ± 0.19
Deep (> 20m)	2.4 ± 0.12	1.5 ± 0.32	1.7 ± 0.28
P-value	0.001	0.014	0.003

All fish displayed some degree of swim bladder inflation (Fig A9, Table A4), even if it was just normal inflation (score of 1). 12 out of the 15 fish in the deep water category ruptured their swim bladder upon capture (mean score of  $2.8 \pm 0.11$ ). None of the shallow water fish ruptured their swim bladder (mean score of  $1.2 \pm 0.10$ ). The scores for inflation of the swim bladder for deep fish were higher than the scores for shallow fish. However, the difference just failed to reach significance ( $P=0.083$ )

Figure A10 shows a deep water fish with protrusion of the eyes or exophthalmia. This was seen in 7 out of the 15 deep water fish compared to no presence of exophthalmia in the shallow water fish (Table A4). Severe exophthalmia and bubble formation inside the eyes was evident in one of the smaller deep water fish.

**Table A4: Mean swim bladder inflation scores and presence of exophthalmia in WA Dhufish upon capture from two depth categories (with standard errors)**

Depth category	Exophthalmia (0=absent, 1=present)	Swim Bladder inflation (score: 1-3)
Shallow (< 20m)	0.0	1.2 ± 0.10
Deep (> 20m)	0.5 ± 0.13	2.8 ± 0.11
P-value	0.002	0.083

None of the symptoms noted in the gross pathology had any relationship with the size of the fish. There was no relationship between size of fish and depth of capture.

#### 4.2. Histopathology

##### Heart

Bubbles and blood clotting were evident in the histopathology examination of the heart for almost all of the fish (Table A5, Figs A11 and A12). Deep water fish had a mean bubble score of  $1.8 \pm 0.19$  compared to a score of  $1.2 \pm 0.14$  for the shallow fish. The difference between bubble scores was significant ( $P = 0.050$ ). Both depth categories had high levels of blood clotting in the heart, with a mean clotting score of  $2.0 \pm 0.19$  for the deep fish and a score of  $1.6 \pm 0.24$  for the shallow fish. There was no significant difference between clotting scores for the different depth categories. Haemorrhaging is not found in the heart as this organ does not have its own circulatory system in WA Dhufish, therefore, there are no vessels which can be ruptured.

**Table A5 Mean damage scores and standard errors for heart histopathology in WA Dhufish upon capture from two depth categories. (Score: 0-3)**

Depth category	Heart bubbles	Heart clotting
Shallow (< 20m)	1.2 ± 0.14	1.6 ± 0.24
Deep (> 20m)	1.8 ± 0.19	2.0 ± 0.19
P-value	0.050	1.000

## Liver

Bubbles, clotting and haemorrhaging were all evident in the tissue of the liver (Table A6). Bubbles were very pronounced in all fish, occurring inside blood vessels and through the pancreatic tissue surrounding the vessels (Figs A13 and A14). Small bubbles were also present in the parenchyma. Mean bubble scores for deep and shallow fish were  $2.1 \pm 0.18$  and  $1.4 \pm 0.20$  respectively. There was no significant difference between depth categories for bubble scores.

Clotting could be seen in and around blood vessels throughout the liver in all of the fish (Fig A13). The level of clotting was significantly higher (mean score of  $2.4 \pm 0.18$ ) in the deep fish than the shallow fish (mean score of  $1.1 \pm 0.18$ ). Liver haemorrhage (Fig A15) was not as pronounced as other effects with scores for deep and shallow fish of  $1.1 \pm 0.19$  and  $0.9 \pm 0.25$  respectively. The difference in haemorrhage scores for the two depth categories was not significant.

Other notable observations in the liver histology were the presence of empty blood vessels and large gaps between the vessels and the parenchyma tissue (Fig A16). Several empty broken vessels were noted, usually with heavy clotting through the damaged areas.

**Table A6: Mean damage scores and standard errors for liver histopathology in WA Dhufish upon capture from two depth categories. (Score: 0-3)**

Depth category	Liver bubbles	Liver clotting	Liver haemorrhage
Shallow (< 20m)	$1.4 \pm 0.20$	$1.1 \pm 0.18$	$0.9 \pm 0.25$
Deep (> 20m)	$2.1 \pm 0.18$	$2.4 \pm 0.18$	$1.1 \pm 0.19$
P-value	0.564	0.005	0.317

## Kidney

Bubbles, clotting and haemorrhaging were all seen in the kidney (Table A7). High mean scores of  $2.6 \pm 0.13$  for deep fish and  $1.9 \pm 0.21$  for shallow fish were recorded for bubbles. Bubbles were usually small and associated with oedema. Occlusion of blood vessels with bubbles were often seen. Some large bubbles were associated with areas of haemorrhaging (Fig A17). The difference between bubble scores for the two depths was significant at a 90% confidence level ( $P = 0.105$ ).

Mean clotting scores were approximately the same for both depth categories with no significant difference found. Clotting was often associated with bubbles inside blood vessels. Haemorrhaging was seen throughout the kidney tissue in the deep fish (mean score of  $1.9 \pm 0.22$ ) as illustrated in

Figure A17. The deep fish scores were significantly higher than the haemorrhage scores for the shallow fish (mean score of  $0.4 \pm 0.22$ ).

Vessel wall damage was evident in the kidney in both depth categories. The large spaces that were present between the vessels and parenchyma in the liver were not present in the kidney.

**Table A7: Mean damage scores and standard errors for kidney histopathology in WA Dhufish upon capture from two depth categories. (Score: 0-3)**

Depth category	Kidney bubbles	Kidney clotting	Kidney haemorrhage
Shallow (< 20m)	$1.9 \pm 0.21$	$1.6 \pm 0.29$	$0.4 \pm 0.22$
Deep (> 20m)	$2.6 \pm 0.13$	$1.5 \pm 0.25$	$1.9 \pm 0.22$
P-value	0.105	0.778	0.003

### Spleen

Table A8 shows that bubbles and clotting were present in the spleen of most fish. Bubbles were mostly small and associated with oedema. Bubbles were also present inside blood vessels. The bubbles scores for deep and shallow fish (mean scores of  $1.8 \pm 0.19$  and  $1.4 \pm 0.15$  respectively) were not significantly different.

**Table A8: Mean damage scores and standard errors for spleen histopathology in WA Dhufish upon capture from two depth categories. (Score: 0-3)**

Depth category	Spleen bubbles	Spleen clotting
Shallow (< 20m)	$1.4 \pm 0.15$	$0.5 \pm 0.17$
Deep (> 20m)	$1.8 \pm 0.19$	$0.9 \pm 0.28$
P-value	0.450	0.599

Clotting in the spleen (Fig A18) was only present in half of the fish, giving low mean clotting scores for both deep and shallow fish ( $0.9 \pm 0.28$  and  $0.5 \pm 0.17$  respectively), with no significant difference between depths. Clotting was often associated with bubble formation inside the blood vessels. Haemorrhaging could not be distinguished in the spleen tissue, however, some damage to vessel walls was evident.

None of the symptoms noted in the histopathology examination had any relationship with the size of the fish.

## 5. Discussion

The most important findings of this study was that there was the presence of bubbles, clotting and haemorrhaging in all fish in both the gross and histopathology examinations. This support the first hypothesis that the Westralian Dhufish suffers damage caused by decompression sickness upon capture. The presence of bubbles is the most important factor in determining the presence of decompression sickness as they are formed as a direct result of the decrease in barometric pressure (Shilling *et al* 1976, Mitchell 1995, Daniels 1984, Boycott *et al* 1908, Smith 1984). In this experiment, bubbles found in the gross examination also corresponded to the presence of bubbles throughout all the major organs in the histopathology examination. Clotting, haemorrhaging and vessel damages are directly related to the pressure of bubbles (Shilling *et al* 1976, Smith 1984). The presence of these forms of damage in both examinations gives further support to the hypothesis

The results indicate that the damage in the deep water fish is greater than the shallow water fish which supports the second hypothesis that damage is greater in fish caught from deep water. With increasing level of bubble formation, there is an associated increase in the other forms of damage (i.e clotting and haemorrhaging). This agrees with the results of Feathers and Knable (1983), Beyer *et al* (1976) and Casillas *et al* (1975). Therefore, increases in the level of bubble formation and other associated damage is related to the extent of decompression.

### 5.1. Gross Pathology

The gross examination of the heart, liver and swim bladder showed that haemorrhaging was significantly higher in the deep water fish. This supports the second hypothesis that damage is greater in fish caught from deep water. However, bubble formation in the fins, opercula and gut flaps did not show significant differences between depth categories. This could be explained by the fact that the gross bubble scores were fairly conservative estimates and yielded a low result. External bubbles in the tissue are very small and invisible to the naked eye. They could be felt popping under the pressure of a finger, however, the severity of formation was too difficult to determine. Combined with this is the short life span of these external bubbles as they disappear quite quickly.

The formation of large gas bubbles in the residue blood in the gut cavity (Plate.2) and the inflation of the lining of the gut and at the base of the gills indicated that gas was being released. Even though this was not associated with any particular organ, it indicates the presence of decompression sickness, therefore, supporting the first hypothesis.

Despite the difference in swim bladder inflation for the two depths not reaching significance ( $P=0.083$ ), 12 out of the 15 fish caught in deep water ruptured their swim bladder, while none of the shallow water fish did. As with all non-parametric statistical analysis, the Mann-Whitney U test is very conservative in predicting a significant difference in results and could explain the non-

significance of the results. However, there was a strong difference in swim bladder inflation between depths and this presents some scope for further research. Exophthalmia, which results from the formation of gas bubbles behind the eye, was present in half of the deep water fish with no evidence in the shallow water fish. This further supports the hypothesis that damage increases with depth.

## 5.2. Histopathology

Significant differences found between depth categories in the histopathology examination are supported by the findings of Feathers and Knable (1983) and Beyer *et al* (1976) and support the second hypothesis being tested. Tissues where the difference in damage scores between depths was not significant could be attributed to the nature of histopathology examination. Because such a thin section of tissue is examined, a damaged area is easily missed by the tissue sectioning process. The fact that not all the differences in damage scores between depths were significant does not reduce the importance of the results. The health of the fish depends on the condition of all its organs, so when the parameters are combined together, deep fish will sustain more damage than shallow fish upon capture.

A large proportion of the bubbles in the liver, kidney and spleen were contained in vessels (Fig A13). Daniels (1984) indicated that the earliest bubbles are intravascular. This is due to the large loads of dissolved nitrogen in the blood. With the reduction in barometric pressure, the body seeks to remove excess nitrogen through the gills via the blood (Shilling *et al*, 1976). Thus, there is huge 'dumping' of dissolved nitrogen from the tissues into the bloodstream. This leads to the occlusion of blood vessels with bubbles coming out of solution. These results are supported by the findings of Feathers and Knable (1983), Beyer *et al* (1976) and Casillas *et al* (1975).

Clotting in the blood vessels arises from the mechanical damage caused by bubbles inside the vessel (Casillas *et al* 1975, Speare 1991). Severe bubble pressure causes vessels to rupture resulting in mass clotting at the damaged sites. The empty blood vessels seen in the liver, kidney and spleen (Fig A16) are due to the breakage of the blood vessel somewhere along its length, resulting in the emptying of the blood from the vessel. The presence of empty vessels agrees with the findings of Kulshrestha and Mandal (1982) in their study of the pathology of gas bubble disease.

The large spaces that are present between the vessels and the parenchyma in the liver (Figs A13 and A16) can also be attributed to intravascular bubbles. The presence of the bubbles causes the vessel to expand, compressing the surrounding parenchyma tissue. When the blood vessel breaks somewhere along its length, the pressure is released and the vessel contracts back to its original form. However, the parenchyma does not return to its original position and a space is left (B.Jones, pers comm). This gap does not occur in the kidney or spleen as these tissues are quite spongy and return to their original shape when the pressure in the vessel is released.

### 5.3. Conclusion

In conclusion, both the hypotheses were supported by the results and are supported by other studies in this area. The damage sustained by the fish is analogous to that found in human decompression sickness and is in agreement with the principles of depressurisation. Management implications cannot be drawn as a result of this study alone, however, if further research indicates that the released fish do not survive as a result of decompression sickness, then new management strategies will need to be found.

A smaller bag limit for recreational fishermen seems to be one of the obvious management options for the WA Dhufish. The current limit of 4 per day is far too high considering the size of these fish. The removal of minimum size limits seems an easy solution to the problem of decompression induced mortalities of released fish. However, fishermen are likely to throw back small Dhufish that are already dead when they land bigger fish. The splitting of the bag limit into a small fish category and a large fish category is also a possible solution to prevent fishermen throwing back dead fish. With increasing pressure on Dhufish stocks, management needs to be reassessed to ensure the conservation of this fishing species.

### 5.4. Scope for Further Research

Further research is required to test the long term survival of WA Dhufish after being caught. Treatment of divers bends involves recompression back to the pressure they were diving at. If fish are quickly returned to depth, can the damage be reduced and will the fish survive? Tagging studies will need to be employed to study the survival of released fish.

Studies by Hills (1970) and Buckles (1968) showed that there was a critical level of bubbles, which if passed would result in death. Is there a critical depth at which fish can be caught and safely returned based on a maximum level of damage that the fish can tolerate?

This study found no relationship between size of fish and the degree of damage, nor was there any correlation between fish size and depth of capture. This lack of relationship agrees with findings by Feathers and Knable (1983), however, disagrees with the findings of Beyer *et al* (1976). It may be an artefact of the small sample size used in this experiment. To find a true relationship, further work must be conducted on long-term survival.

The fact that 12 of the 15 fish in deep water ruptured their swim bladder compared to no rupturing in the shallow water may pose a problem for management. A fish with a ruptured swim bladder would have little chance of survival if returned. It would not be able to remain neutrally buoyant and would sink to the bottom where it would be highly vulnerable to predation.

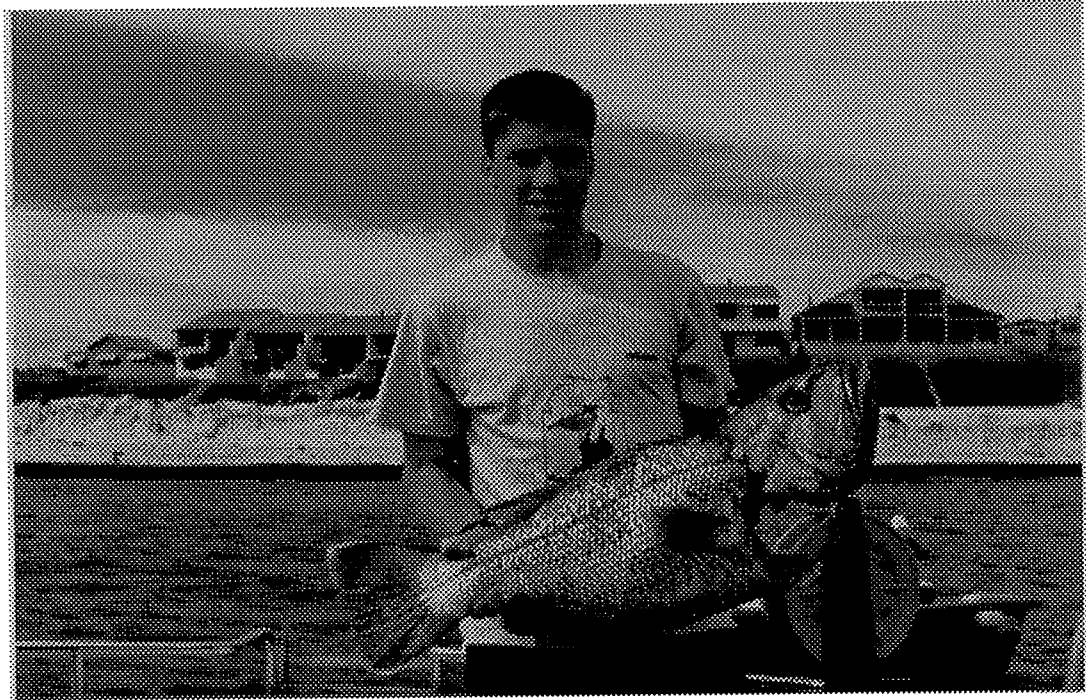
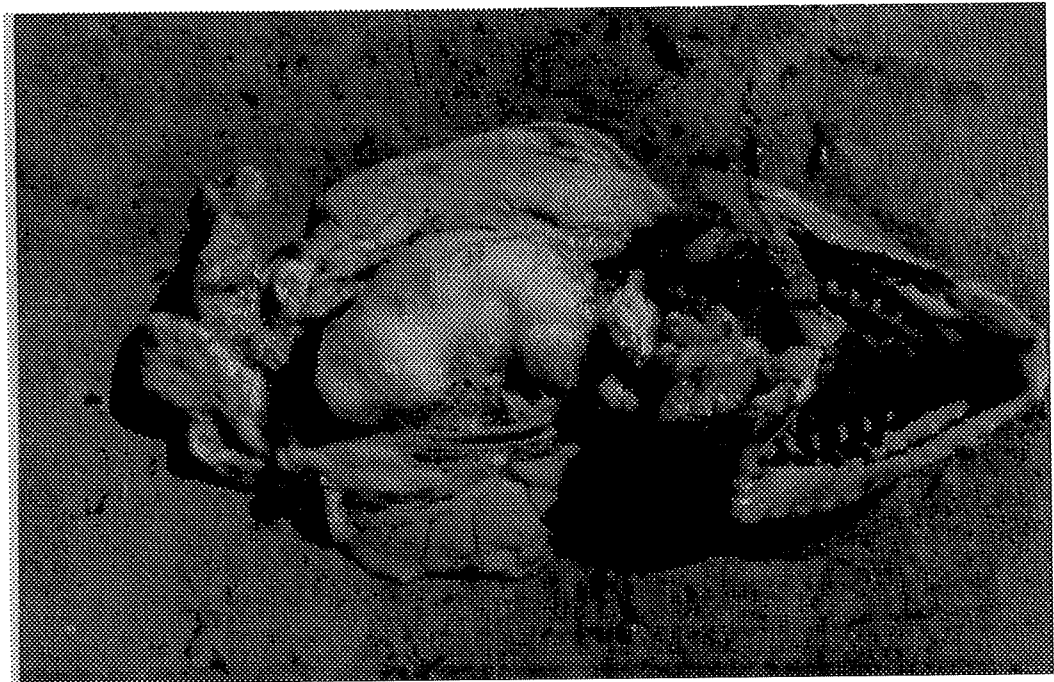

**Figure A3: The Wetralian dhufish**



**Figure A4: The formulation of bubbles in the residue blood in the gut cavity**





**Figure A5: Shallow water fish with minor haemorrhage in the liver (red smear in yellow lobe at top of photo).**



**Figure A6: Deep water fish with moderate to severe haemorrhage in liver (red smearing through the yellow lobes).**



**Figure A7: Slight haemorrhaging in the capillaries on the inside of the swim bladder of a shallow water fish.**



**Figure A8: Severe haemorrhaging in the capillaries on the inside of the swim bladder of a deep water fish.**

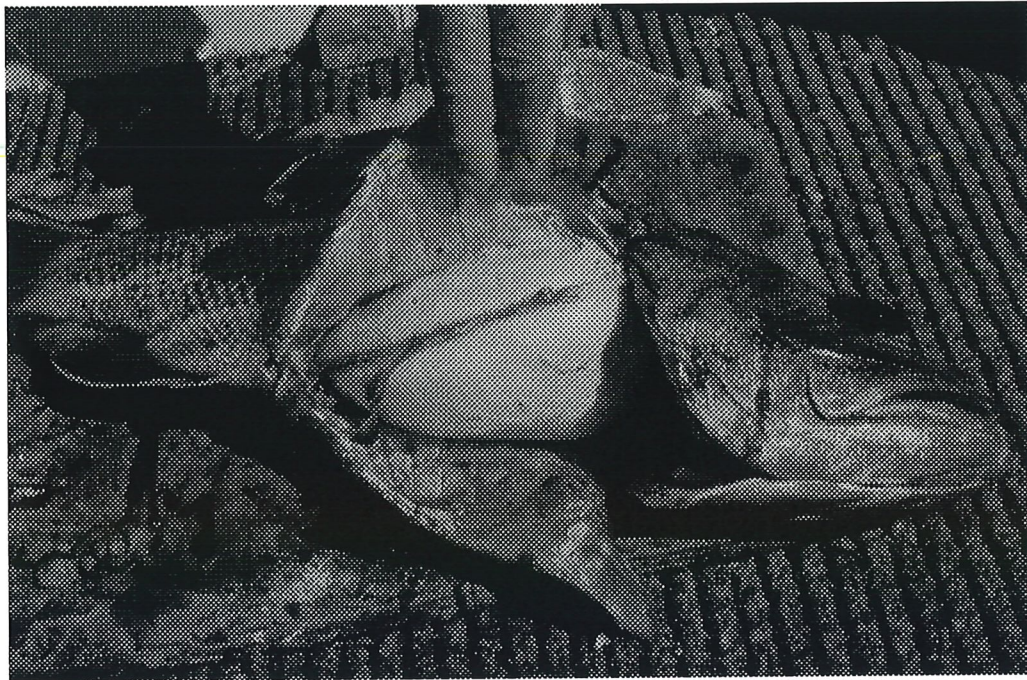

**Figure A9: Heavy inflation of the swim bladder in shallow water fish**



**Figure A10: Exophthalmia (protrusion of the eyes) in a deep water fish.**

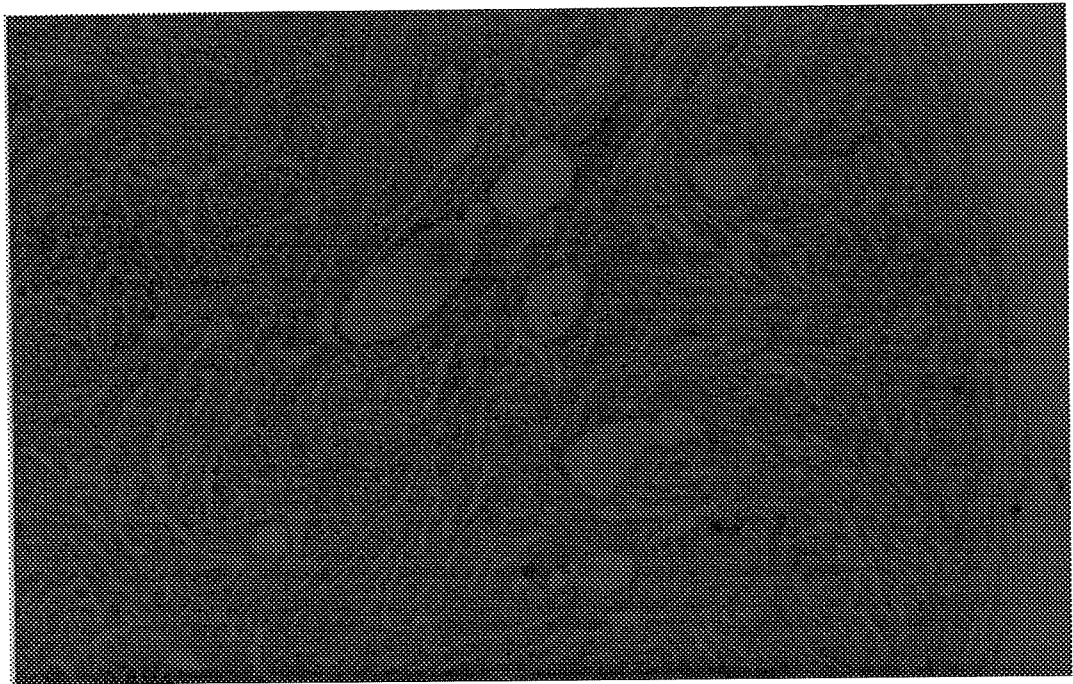

**Figure A11: (4x) Large bubbles in the tissue of the heart of a deep water fish.**

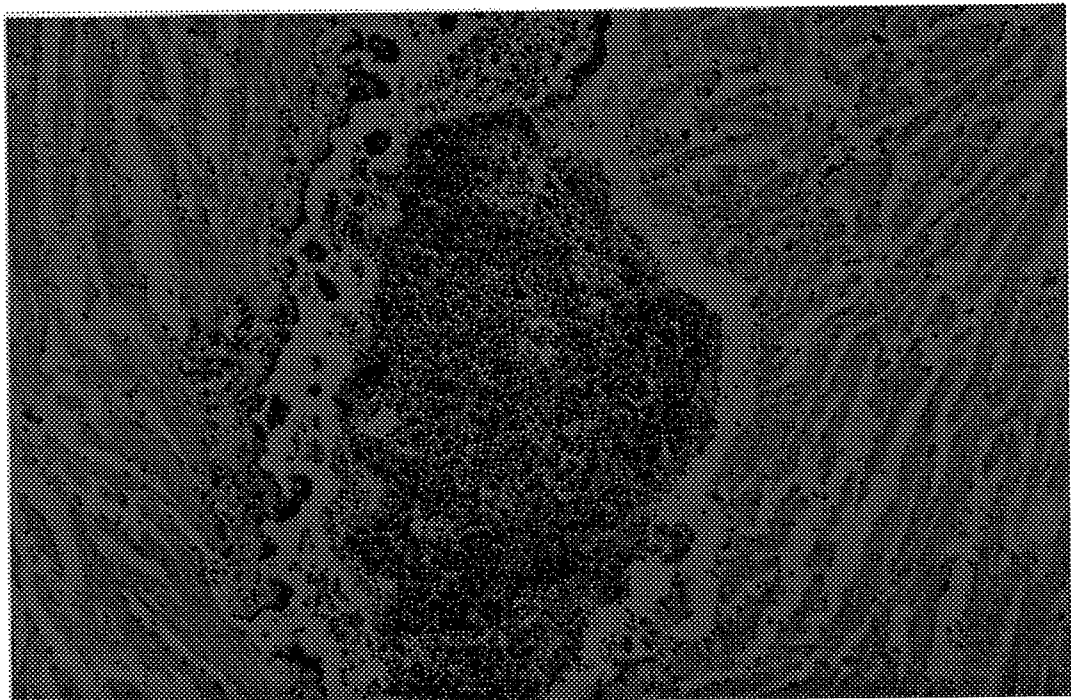

**Figure A12: (10x) Heavy clotting in the heart tissue of a deep water fish.**



**Figure A13: (4x) Bubbles and clotting occluding a blood vessel in the liver of a deep water fish.**

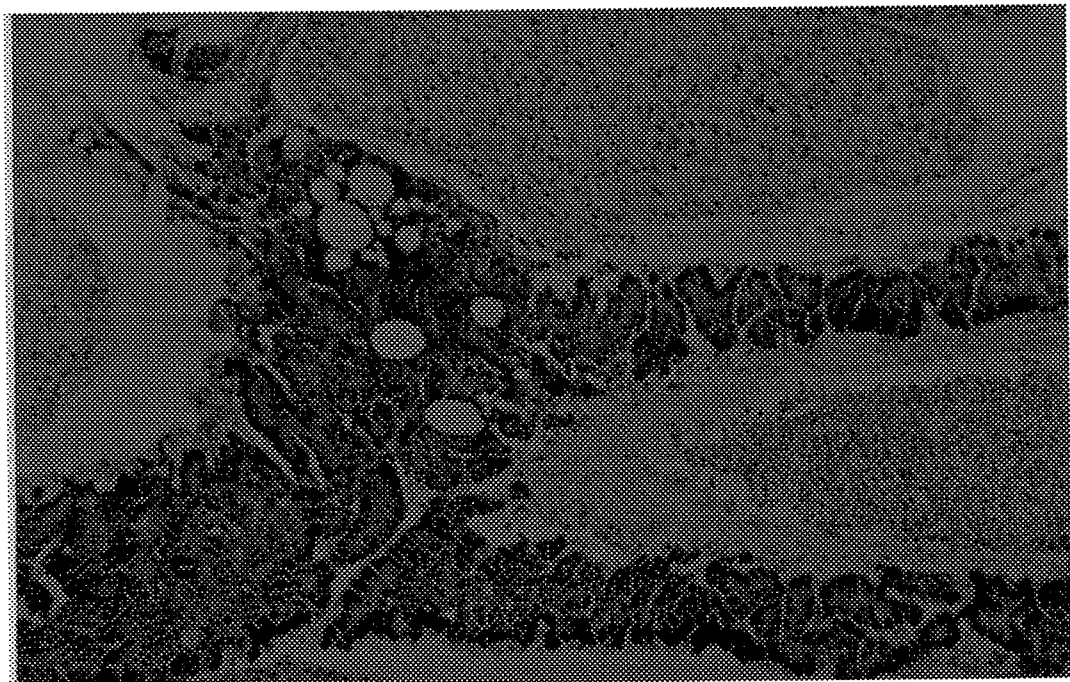

**Figure A14: (10x) Large bubbles in the pancreatic tissue (purple tissue) surrounding a blood vessel in the liver.**

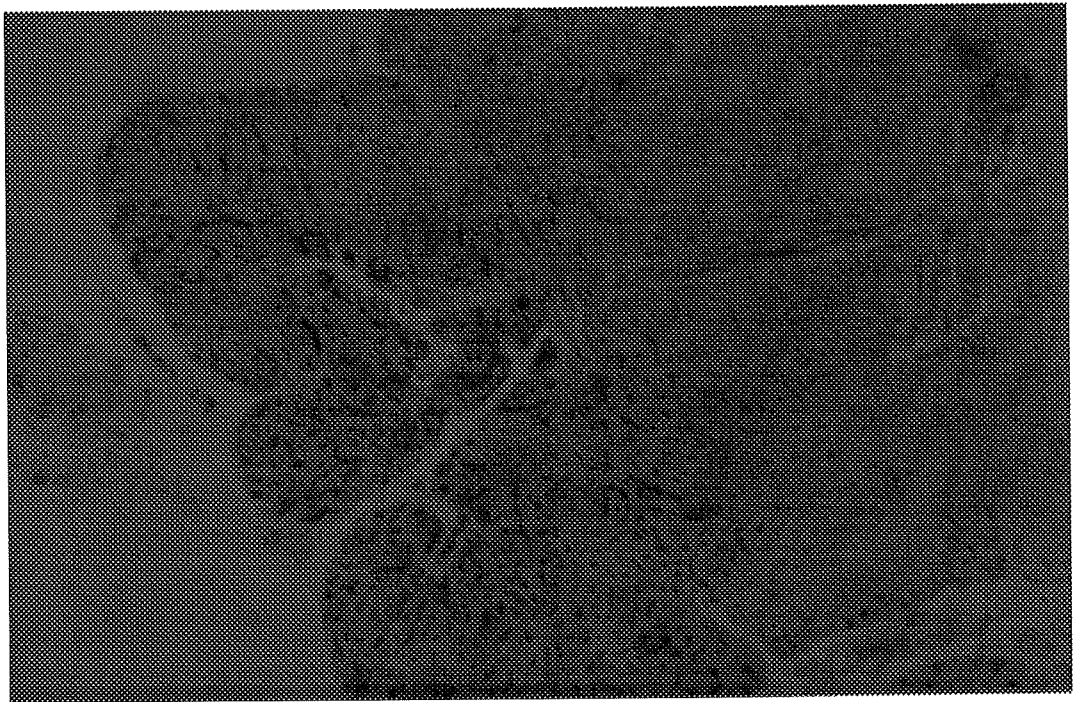

**Figure A15: (4x) Severe haemorrhaging in the liver of a shallow water fish.**

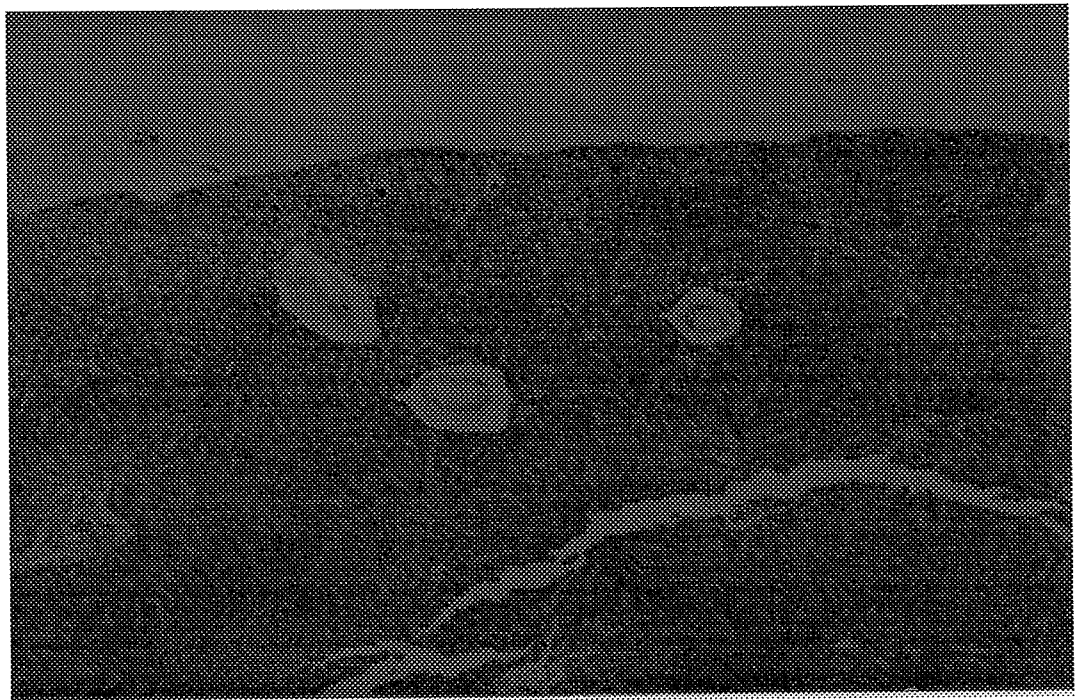

**Figure A16: (4x) Empty blood vessels with large spaces between the vessel and the liver parenchyma.**

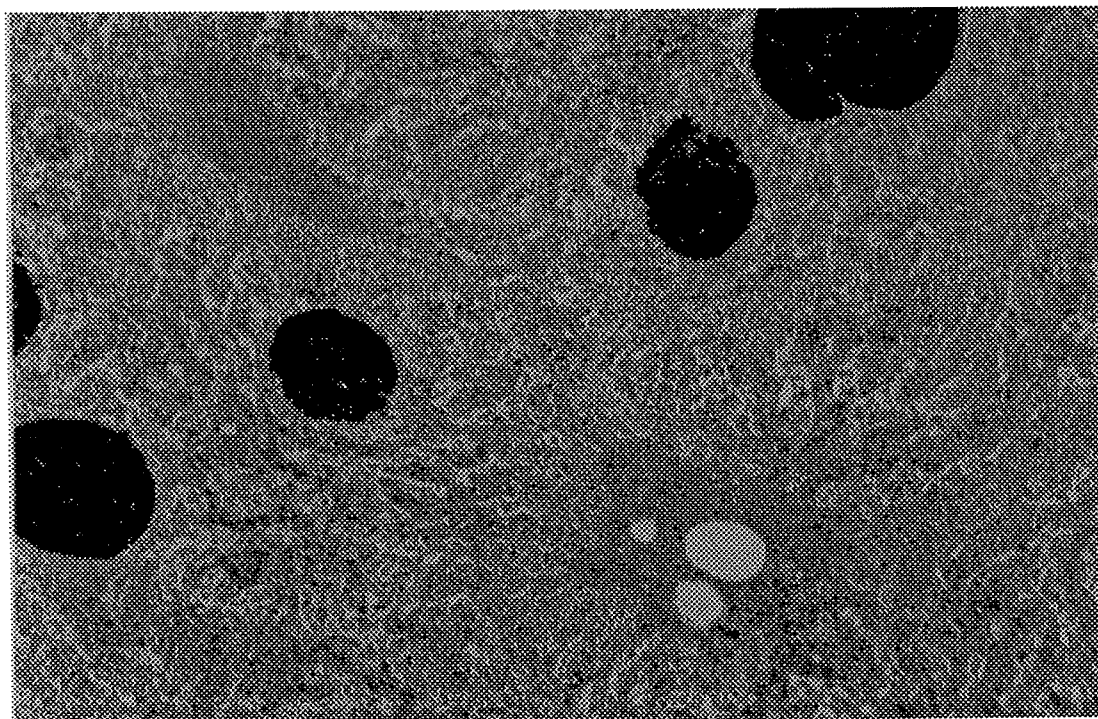

**Figure A17: (10x) Haemorrhaging with large bubble formation in the tissue of the kidney.**

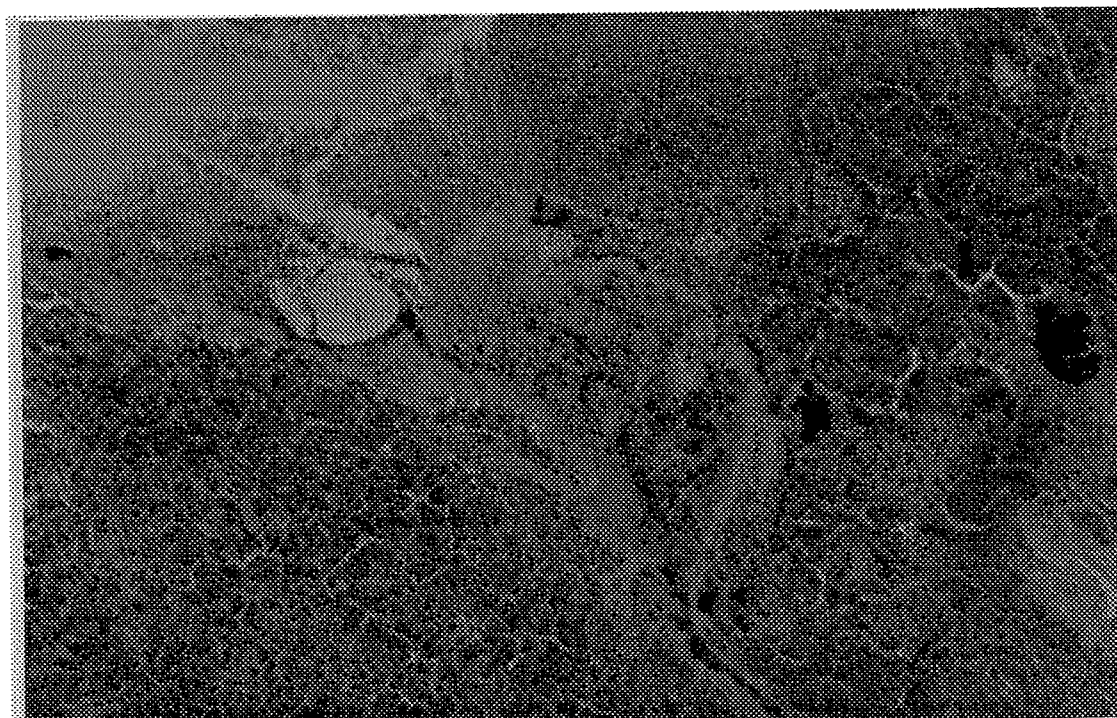

**Figure A18: (10x) Heavy clotting in the spleen of a deep water fish (pink area in centre with white blood cell accumulation).**

## References

- Beyer, D.L., D'Aoust, B.G. and Smith, L.S. (1976) Decompression-induced bubble formation in salmonoids: comparison to gas bubble disease. *Undersea Biomedical Research* **3** (4), 321-338.
- Boycott, A.E., Damant, G.C.C. & Haldane, J.S. (1908) The prevention of compressed air illness. *J. Hyg.(London)* **8**, 342-443.
- Broecker, W.S. (1974) *Chemical Oceanography*. Harcourt, Brace, Jovanovich, New York, 115-119.
- Buckles, R.G. (1968) The physics of bubble formation and growth. *Aerospace Medicine* 1062-1069.
- Casillas, E., Miller, S.E., Smith, L.S. and D'Aoust, B.G. (1975) Changes in hemostatic parameters in fish following rapid decompression. *Undersea Biomedical Research* **2** (4), 267-276.
- Clay, J.R. (1963) Histopathology of experimental decompression sickness. *Aerospace Medicine* **34**, 1107-1110.
- D'Aoust, B.G. and Smith, L.S. (1974) Bends in fish. *Comp. Biochem. Physiol.* **49A**, 311-321.
- Daniels, S. (1984) Ultrasonic monitoring of decompression procedures. In: *Diving and Life at High Pressures*. The Royal Society, London, 153-170.
- Feathers, M.G. and Knable, A.E. (1983) Effects of decompression upon Largemouth Bass. *North American Journal of Fisheries Management* **3**, 86-90.
- Ferguson Wood, E.J. (1975) *The Living Ocean*. Croom Helm, London, 74.
- Ferguson, H.W. (1989) *Systemic Pathology of Fish*. Iowa State University Press, Ames, Iowa.
- Fisheries Department of Western Australia (1993) Fish for the future card No. 2
- Harvey, H.W. (1955) *The Chemistry and Fertility of Sea Waters*. Cambridge University Press, London, 183-187.
- Hills, B.A. (1970) Limited supersaturation versus phase equilibrium in predicting the occurrence of decompression sickness. *Clinical Science* **38**, 251.
- Kulshrestha, A.K. and Mandal, P.K. (1982) Pathology of gas bubble disease in two air breathing catfishes (*Clarias batrachas* Linn. and *Heteropneustes fossilis* Bloch.) *Aquaculture*, **27**, 13-17.
- Mitchell, S.J. (1995) The role of lignocaine in the treatment of decompression illness. A review of the literature. *SPUMS Journal* **25** (4), 182-194.
- Philp, R.B. (1974) A review of blood changes associated with compression-decompression: relationship to decompression sickness. *Undersea Biomedical Research* **1** (2), 117-150.
- Rakestraw, N.W. and Emmel (1937) The relation of dissolved oxygen to nitrogen in some Atlantic waters. *Journal of Marine Research* **1**, 207-216.
- Riley, J.P. and Chester, R. (1971) *Introduction to Marine Chemistry*. Academic Press, London, 111-115.
- Saunders, R.L. (1953) The swimbladder content of some freshwater fish with particular reference to the physostomes. *Canadian Journal of Zoology* **31** (6), 547-560.



- Shilling, C.W., Werts, M.F. and Schandelmeier, N.R. (1976) *The Underwater Handbook*. Plenum Press, New York and London, 85-90, 467-505.
- Smith, E.B. (1984) The biological effects of high pressures: Underlying principles. In: *Diving and Life at High Pressures*. The Royal Society, London, 5-16.
- Speare, D.J. (1990) Histopathology and ultrastructure of ocular lesions associated with gas bubble disease in Salmonoids. *J. Comp. Path.*, **103**, 421-432.
- Speare, D.J. (1991) Endothelial lesions associated with gas bubble disease in fish. *J. Comp. Path.*, **104**, 327-335.
- Strauss, R.H. (1979) Diving Medicine. *American Review of Respiratory Disease*, **119**, 1001-1023.
- Sverdrup, H.U., Johnson, M.W. and Fleming, R.H. (1942) *The Oceans: Their Physics, Chemistry and General Biology*. Prentice Hall, New York, 186-192.
- Thomson, W.A.R. (1967) *Black's Medical Dictionary* 27<sup>th</sup> Ed. Adam and Charles Black, London.
- Walton Smith, F.G. (1974) *Handbook of Marine Science Vol 1*. CRC Press, Ohio.
- Weitkamp, D.E. and Katz, M. (1980) A review of dissolved gas supersaturation literature. *Transactions of the American Fisheries Society*, **109**, 659-702.
- Zar, J.H. (1941) *Biostatistical Analysis* 3<sup>rd</sup> Ed. Prentice Hall, New Jersey, c1996.

## **Appendix B    *Suitability of bore salt-water and ocean water for rearing dhufish***

At the ADU there are two sources of salt water available. Ocean-intake water is pumped directly from the ocean, while bore salt-water is pumped from 18m below ground approximately 10m from the shoreline. The quality of ocean-intake water is greatly affected by the conditions of the adjacent Swan River Estuary. Storms and heavy rainfall can cause high sediment loads, and decreased salinity. Maintenance of water quality is particularly a problem during the winter months, when storms and high winds are common in Perth. Maintenance of pumps and filters during these months is expensive and time-consuming. In contrast, bore salt-water is not affected by the Swan River and is clean. Little filtration is needed before use in the hatchery, making bore salt-water cheap and efficient to maintain. Bore salt-water chemistry, however, differs to ocean-intake water, with the main area of concern being its high carbon dioxide levels coupled with low pH.

Over the past two years, bore salt-water had been used increasingly at the ADU. All larviculture and juvenile grow-out of snapper, black bream, King George whiting and dhufish are now conducted in bore salt-water with excellent results. In February 1999, due to a need for extensive maintenance on the ocean-intake pumps and filters, all broodstock at the ADU were temporarily converted to bore salt-water. Initially, no ill effects of the bore salt-water were noted among any of the broodstock (including snapper, black bream, King George whiting, and dhufish). A management decision was therefore made to keep the bore salt-water on in an effort to maintain better water quality during the winter months and reduce maintenance costs and labour. Most of the broodstock at the ADU of various species (other than wild-caught dhufish) continued to appear to thrive. Dhufish broodstock feed rates declined however, and six months after the bore salt-water had been turned on, wild-caught dhufish broodstock began to deteriorate and more than twenty of the thirty two fish caught as broodstock that year died over a period of several months. All these fish had been caught in shallow water (<20m) and handled according to best practice at the ADU. Fish health experts at Fisheries WA were unable to identify a particular cause of death. All fish that died had not eaten for some time. The ocean water was turned back on in November 1999, solely for the wild-caught dhufish. The health of the surviving wild-caught fish improved and they began to feed more vigorously, however, few sexually matured and those that did were weak and unable to withstand the rigours of hormonal manipulation.

As it was not possible to compare the health and survival of dhufish held in bore salt-water and ocean-intake water concurrently, it is impossible to determine whether the bore salt-water was the cause of the mortalities or not. Observations on feeding and behaviour, however, strongly suggest a connection. Similar mortality rates have not been observed in hatchery-reared dhufish. This is likely to be due to the fact that hatchery-reared fish are generally more tolerant to stress than their wild-caught counterparts. Further support for the difference in tolerance to bore water between hatchery-reared and wild-caught fish is given by observations on a bore-water tank containing 20 hatchery-reared dhufish and 2 wild-caught males. Although hatchery-reared fish continued to feed and thrive, the two males gradually stopped feeding and lacked vigour. In a similar tank, stocked with similar fish but run on ocean intake water, the two wild-caught males ate substantially more than their bore-water counterparts at equal temperature. The bore-water tank was therefore turned to ocean water and feeding increased in the males.

Since bore water is likely to be widely used in land-based aquaculture ventures the question of the suitability of bore salt-water for the culture of dhufish and other species must be fully explored and techniques developed for making it suitable, such as properly removing CO<sub>2</sub> or other contaminants. Addressing these issues is now a high priority at the ADU.

### Appendix C Specifications for vitamin and mineral premix

The diet of captive dhufish is supplemented regularly with vitamins and minerals. The vitamins and minerals are ordered from Gloucester Park Rural Industries, Leeville NSW according to the specifications in Table A9. It is supplied in two parts: Part A contains the vitamins in a sodium bicarbonate base; Part B contains minerals. These are mixed in 1:1 ratio and then stored in an airtight container in a refrigerator until use. The premix is administered to wild-caught broodstock in a gelatine capsule. The capsules are filled with the premix (0.6g/capsules) and then inserted into the feed prior to feeding. Approximately one capsule is given per kilogram of fish. Capsules are fed 3 times a week for two weeks every month. For hatchery-reared broodstock and juveniles, the premix is incorporated in a moist pellet at an inclusion rate of 0.5%/kg. The vitamin-enriched pellet comprises about 20% of the total diet (Refer to Appendix D for recipe for the moist pellet).

**Table A9: Specifications for vitamin and mineral premix.**

Supplement	Source Ingredient	Amount of Source Ingredient (g/kg premix)	Amount of Active Ingredient (unit/kg premix)	Amount of Active Ingredient/Capsule (1 capsule = 0.6 g premix)
<b>Part A: Vitamins</b>				
A	Vitamin A/D3 (500/100)	2.2	1,103 x 10 <sup>6</sup> IU	662,251 IU
D			220 x 10 <sup>6</sup> IU	132,450 IU
B1	Vitamin B 1 (100%)	2.8	2.8 g	1.7 mg
B2	Vitamin B 2 (80%)	4.6	3.7 g	2.2 mg
B3	Niacin (100%)	36.8	36.8 g	22.1 mg
B6	Vitamin B 6 (100%)	2.8	2.8 g	1.7 mg
B12	Vitamin B12 (1%)	0.4	0.004 g	0.002 mg
C	Vitamin C (90%)	184.5	166.0 g	99.6 mg
E	Vitamin E (50%)	73.6	36.8 g	22.1 mg
K	Hetrazeen K 3 (22.7%)	16.2	3.7 g	2.2 mg
Pantothenic acid	D-Calcium Pantothenate (100%)	9.2	9.2 g	5.5 mg
Folic acid	Folic (95%)	1.0	0.961 g	0.6 mg
Biotin	Biotin (2%)	9.2	0.183 g	0.1 mg
Inositol	Inositol (100%)	92.0	92.0 g	55.2 mg
Astaxanthin	Astaxanthin (8%)	23.0	1.8 g	1.1 mg
Ethoxyquin	Ethoxyquin (66%)	41.9	27.621 g	16.6 mg
Base	Sodium Bicarbonate	36.8	36.8 g	22.1 mg
<b>Part B: Minerals</b>				
Choline	Choline Chloride (60%)	423.4	254.1g	152.4 mg
Iodine	Potassium Iodide (90/10) (68% I)	0.2	0.1 g	0.069 mg
Copper	Copper Sulphate (25%)	2.0	0.5 g	0.3 mg
Iron	Ferrous Sulphate (30%)	16.9	5.1 g	3.0 mg
Manganese	Manganese Sulphate (31%)	4.7	1.5 g	0.882 mg
Zinc	Zinc Sulphate Mono (31%)	47.1	14.6 g	8.8 mg
Selenium	Sodium Selenite (1%)	5.6	0.1 g	0.034 mg
<b>Total</b>		<b>1 kg</b>		

## Appendix D Recipe for the moist pellet

Moist pellets are fed to hatchery-reared dhufish as a vector for administering vitamin supplements and other oral treatments (after Glencross *et al*, 1999).

Ingredients are outlined in Table A10. Whole pilchards, prawns and squid are minced, before being combined with dry ingredients (vitamins/minerals, gluten and fishmeal). All ingredients are mixed thoroughly using a commercial mixer. Fish oil and water are then added to make dough. The amount of water is adjusted to ensure the dough is of the desired consistency. The dough is then covered and placed in the refrigerator overnight to allow it to rest (this makes it easier to pass through the pasta maker) and to chill the dough prior to pressing (to counteract the heat generated by the pasta maker). The dough is then transferred into a pasta maker fitted with an appropriate sized die (depending on the size of pellet being made). Pellets are then baked in the oven at 80°C until a slight crust is formed (approximately 2 hrs), before being cooled at room temperature. When cool, the pellets are placed in airtight containers and stored in the freezer for up to 1 month.

**Table A10: Ingredients for moist pellet. After Glencross *et al*, 1999**

Ingredient	Inclusion (%)	g/kg
Vitamin/Mineral premix	0.50	5.00
Water	12.00	120.00
Fish oil	5.00	50.00
Wheat gluten	10.00	100.00
Fish meal	42.50	425.00
Fresh pilchards	10.00	100.00
Whole prawns	10.00	100.00
Whole squid	10.00	100.00

### References

Glencross, B.D., Van Barnveld, R.J., Carter, C.G. and Clarke, S.M. (1999). On the path to a manufactured feed for farmed Southern Bluefin Tuna. *World Aquaculture Society Journal* 30: 42-46

## **Appendix E    *Technique for making and administering an LHRHa slow-release cholesterol pellet***

LHRHa slow release cholesterol pellets are used to stimulate ovulation in captive female dhufish and to maintain spermiation in captive males. The dose used for females is  $50\mu\text{g.kg}^{-1}$  and for males is  $10\mu\text{g.kg}^{-1}$ . The pellets are made according to Lee *et al* (1986). Brief details are given below, however, Lee *et al* (1986) should be referred to for more details.

### **Making hormone pellets**

#### *Ingredients*

- LHRHa – Sigma (L4513)
- Cholesterol – Sigma (C8667)
- Copha – available from supermarkets
- 50% ethanol (10 ml analytical grade ethanol plus 10ml distilled H<sub>2</sub>O)

#### *Equipment*

- Pellet Mould – constructed of 10mm perspex with 1.6 mm holes drilled right through.
- Backing plate – a piece of perspex the same size as the pellet mould
- Ram – this is a metal rod that fits neatly inside the holes drilled in the pellet mould. This is used to compress the pellet mixture to form a pellet
- Small hammer – this is used to apply pressure to the ram to form the pellet
- Analytical balance to weigh individual pellets
- Drying oven set at 37°C

#### *Procedure*

1. Dissolve 4mg LHRHa in 0.5 ml of 50% ethanol in 50ml vial
2. Add 380mg cholesterol and mix well
3. Place mixture in the drying oven for 1h at 37°C
4. Add 20mg of cocoa butter (2 drops if molten) and mix thoroughly until its consistency is flaky.
5. Place a small amount of mixture into a hole in the pellet mould using a spatular.

6. Place the backing plate behind the mould and using the ram and hammer, compress the mixture. Keep adding the mixture and compressing until the mould is full and a pellet has been formed.
7. The pellet is then ejected from the mould by removing the backing plate and pushing the pellet out using the ram and hammer.
8. If the pellet falls apart add more copha to the mixture and try again. Take careful note of the weight of any extra copha additions, as this will be required for calculation of hormone concentration.
9. Calculate exact concentration of LHRHa in the pellet mixture and determine required weight of each pellet.
10. Cut each pellet to the size required (use analytical balance) and place individually in small labelled vials. Cut pellets to different sizes (within the range likely to be required). Vials should be labelled with date, amount of hormone/pellet and the weight of the pellet.
11. Pellets are stored in the freezer until use.

### **Administering pellets**

#### *Equipment*

- scales
- 1.8mm internal bore needle (similar to a recycled PIT tag needle)
- PIT tag applicator
- foam restraint

#### *Procedure*

1. Sterilise in alcohol all equipment to be used in administering the pellet (needle, forceps, probe).
2. Anaesthetise fish
3. Weigh the fish and calculate the amount of hormone required
4. Select an appropriately sized pellet and load into a recycled PIT tag needle. Use forceps and/or a metal probe to do this,
5. Attach loaded needle to a PIT tag applicator or similar.
6. Place the anaesthetised fish ventral side up in a foam restraint.

7. Implant the pellet intraperitoneally by sliding the needle under a scale and through the flesh into the abdominal cavity, about 5 scales posterior to the pelvic fins (Fig A19). Once the needle is in place the plunger on the tag applicator is pushed to eject the pellet.

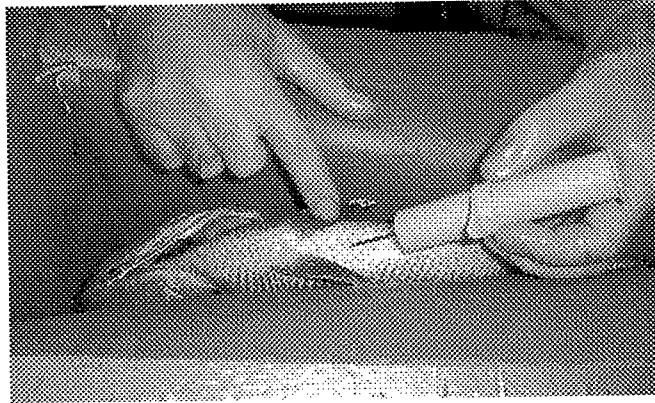

**Figure A19: Implanting a slow-release cholesterol pellet into a sexually mature female held in a foam restraint**

#### Reference

- Lee, C. S., Tamaru, C.S. and Kelley, C.D. (1986). Technique for making chronic-release LHRH-a and 17a-methyltestosterone pellets for intramuscular implantation in fishes. *Aquaculture* 59: 161-168



## **Appendix F     Stimulating in-tank spawning**

### **Introduction**

Procedures for hormonal induction of ovulation and subsequent stripping are sometimes the only means of obtaining eggs. Nevertheless, these procedures can negatively affect both the success of the procedure and the health of the broodstock. Stress imposed by capture and handling is known to affect reproduction in a wide range of species (reviewed in Pankhurst, 1998). Most techniques for administering hormones to induce ovulation and spawning require that the fish first be caught and handled. This is a major disadvantage as the stress may impair the efficacy of the hormone treatment. Furthermore, repeated stripping episodes can result in physical damage to the fish and in extreme cases, death. In addition, once eggs have ovulated, they must be stripped within the window of peak viability. Successful hand stripping in species with a short window of viability requires that the precise time of ovulation be predicted. If the fish spawns, however, the dependence on human interpretation is removed, as is the need to subject the fish to handling protocols. Therefore two pilot studies were conducted to investigate the use of hormones to stimulate in-tank spawning in dhufish and to eliminate handling during the process of hormonal treatment.

### *Part A*

On two separate occasions during the 1996/97 spawning season, dhufish treated with a low dose of exogenous hormone released eggs in the tank which were subsequently fertilised by the resident male (FRDC report, June 1997). On one occasion the female was treated with a luteinising hormone releasing hormone analogue (LHRHa) pellet (5 :g.kg<sup>-1</sup>) followed three days later by a LHRHa injection (5 :g.kg<sup>-1</sup>). On the other occasion the female was treated with an injection of Ovaprim<sup>®</sup> (6 :g GnRH.kg<sup>-1</sup>). In the following season we sought to confirm these results in a controlled manner using a low dose of LHRHa.

### *Part B*

Dietary administration of hormones does not require pre-treatment handling and so avoids possible negative stress effects. This technique has not been widely investigated, however, it has been used successfully in several species including spotted seatrout (*Cynoscion nebulosus*; Thomas and Boyd, 1989), sable fish (*Anoplopoma fimbria*; Solar *et al.*, 1990), goldfish (*Carassius auratus*; Suzuki *et al.*, 1988), Thai carp (*Puntius gonionotus*; Sukumasavin *et al.*, 1992) and coho salmon (*Oncorhynchus kisutch*; McLean *et al.*, 1991). The dose required for successful oral administration is normally higher than is typically used in injections. Solar *et al.*, (1990) reports that the dose required to induce ovulation in sable fish by oral intubation was 10-fold greater than for injection. Other workers report doses of between 0.5 and 3 mg.kg<sup>-1</sup> (Thomas and Boyd, 1989). Although LHRHa administered by injection and slow-release

cholesterol based pellet has been demonstrated to be effective in inducing ovulation in dhufish (Pironet, and Neira, 1998, Appendix G and M this volume), the efficacy of administering LHRHa orally has not been investigated. Therefore a trial was conducted (within the natural dhufish spawning season) to test the efficacy of oral administration of LHRHa to stimulate ovulation and spawning in dhufish.

## Methods

### Part A

In January 1998, three females in a 50 m<sup>3</sup> tank were treated with 5 :g/kg LHRHa slow release cholesterol pellets (Appendix E), followed 3 days later by a 5 :g.kg<sup>-1</sup> LHRHa saline-based injection. The remaining 2 females in the tank were treated identically but with a blank pellet and a saline injection (control). Similarly, in another tank (20m<sup>3</sup>), two females were treated with LHRHa and two with a control. The dose used, however, was 10 :g.kg<sup>-1</sup> (LHRHa or control equivalent) for both implant and injection. Following the injection, all fish were left undisturbed for a further 96 h post injection to enable time for release of the eggs. At 96h after the injection, the tanks were drained and the fish stripped to check for ovulation. Oocyte diameters prior to implant were between 550 and 700 :m. Tanks were fitted with egg nets on water overflows to trap any eggs released in the tank. Egg nets were checked daily for released eggs.

### Part B

In one tank (50m<sup>3</sup>), 2 females were fed their normal flesh diet with LHRHa injected into the flesh of the food so that each fish received a hormone dose of approximately 0.05 mg.kg<sup>-1</sup>. In a separate tank (40m<sup>3</sup>), two females were fed the same diet, however, the food was injected with a corresponding volume of saline solution (no LHRHa). The remaining three fish per tank were fed their normal diet without injection. This procedure was repeated weekly and then twice weekly to the same fish for 21 days. The dose of LHRHa (and corresponding saline dose) doubled each time (Table A11). The final dose used was 0.8 mg.kg<sup>-1</sup> LHRHa on Day 21. Due to the requirement not to disturb the fish, no attempt was made to assess stage of maturation (by gonadal biopsy) of the females prior to the experiment.

All tanks were fitted with egg nets and these were checked daily for any eggs released into the tank. Observations were made daily (prior to feeding) of each fish to identify any change in the size of the abdomen which may indicate developing oocytes or ovulation.

**Table A11: Schedule for oral administration of LHRHa to captive female dhufish.**

Day of treatment	1	8	15	18	21
Dose (or equivalent) (mg LHRHa.kg <sup>-1</sup> )	0.05	0.1	0.2	0.4	0.8

## Results/Discussion

### Part A

In the 50m<sup>3</sup> tank (fish treated with LHRHa at 5 :g.kg<sup>-1</sup> or control equivalent) there was no external evidence of ovulation (swelling of abdomen) or of spawning (eggs in egg collector). At 96h after treatment, ovarian biopsies showed that none of the LHRHa-treated fish ovulated, while one of the control fish ovulated. Less than 500 poor quality eggs were stripped from this fish. In the 20 m<sup>3</sup> tank, the abdomen of fish treated with LHRHa (10:g.kg<sup>-1</sup>) swelled from 48h post injection, however no eggs were found in the collector, indicating that the fish did not spawn. At 96h post injection, the ovaries were excessively swollen and contained multiple batches of over-ripe ovulated eggs. Neither of the control fish ovulated.

The results from these trials indicate that the in-tank spawning that occurred in 1996/1997 are not readily reproducible. This is probably due the complex and interrelated nature of factors that affect the behavioural act of spawning (Pankhurst, 1998). These may include water temperature, tank dimension, tank-side disturbance, substrate availability and/or photoperiod. Clearly, it is not simply related to the correct hormone dose.

### Part B

Eggs were not released in either the control or the LHRHa-treated tank, nor was there any visual evidence of ovulation (i.e. abdominal swelling) following any of the doses. The trial was terminated at this point since the high concentration of LHRHa required, high cost of the product and limited stocks of LHRHa precluded the use of higher doses.

The maximum dose tested in the current study was 0.8 mg.kg<sup>-1</sup>. In other species the dose rate is slightly higher. Oral administration of LHRHa (1-2 mg LHRHa.kg<sup>-1</sup> of body weight) successfully induced spawning in spotted seatrout (*Cynoscion nebulosus*; Thomas and Boyd, 1989). Sablefish (*Anoplopoma fimbria*) were orally intubated with LHRHa at 1 mg/kg of body weight, followed by another dose at 0.5 mg.kg<sup>-1</sup> 11 days later. This treatment resulted in three out of four treated sablefish ovulating 3 to 7 days after the second treatment (Solar *et al*, 1990). Therefore it is possible that the dose used in the current study was too low to induce a response. A higher dose should be tested.

Alternatively, these negative results may suggest that LHRHa is not readily absorbed through the gut, or that it is being broken down in the gut before absorption. Since the stage of maturation was not assessed prior to the experiment it is also possible that the gonads were not developed sufficiently for the LHRHa to have an effect. In order to confirm the cause of this lack of response, however, further work needs to be done. One way of approaching this problem would be to orally administer LHRHa in combination with a blood-sampling regime. Analysis of plasma 17 $\beta$ -estradiol and testosterone levels would indicate whether a gonadotropin surge was stimulated following oral administration of LHRHa, and hence whether LHRHa can be absorbed through the dhufish gut.

**References**

- McLean, E.M., Parker, D.B., Warby, C.M., Sherwood, N.M. and Donaldson, E.M. (1991). Gonadotropin release following oral delivery of luteinizing hormone-releasing hormone and its superactive analogue (des-Gly<sup>10</sup>[D-Ala<sup>6</sup>]LHRH ethylamide) to 17 $\beta$ -oestradiol-primed coho salmon, *Oncorhynchus kisutch* (Walbaum). *Journal of Fish Biology* 38: 851-858
- Pankhurst, N.W. 1998. Reproduction. Pages 1-26 in. K. Black and A.D. Pickering editors. *Biology of Farmed Fish*. Sheffield Academic Press, Sheffield.
- Pironet, F.N and Neira, F.J. 1998. Hormone induced spawning and development of artificially reared larvae of the West Australian dhufish, *Glaucosoma hebraicum* (Glaucosomatidae). *Marine and Freshwater Research* 49: 133-42
- Solar, I.I., McLean, E., Baker, I.J., Sherwood, N.M. and Donaldson, E.M. (1990). Induced ovulation in sablefish *Anoplopoma fimbria* (Pallas, 1811), following oral administration of des Gly<sup>10</sup>(D-Ala<sup>6</sup>) LHRH ethylamide. *Fish Physiology and Biochemistry* 8: 497-499
- Suzuki, Y., Kobayashi, M., Nakamura, O., Aida, Katsumi and Hanyu, I. (1988). Induced ovulation of the goldfish by oral administration of salmon pituitary extract. *Aquaculture* 74: 379-384
- Sukumasavin, N., Leelapatra, E., McLean, E. and Donaldson, E.M. (1992). Orally induced spawning of Thai carp (*Puntius gonionotus* Bleeker) following co-administration of des Gly<sup>10</sup>(D-Arg<sup>6</sup>) sGNRH ethylamide and domperidone. *Journal of Fish Biology* 40: 477-479
- Thomas, P. and Boyd, N.W. (1989). Dietary administration of an LHRH analogue induces spawning of spotted seatrout (*Cynoscion nebulosus*). *Aquaculture* 80: 363-370

## **Appendix G    *The response of acclimated female dhufish to implant with LHRHa slow-release pellet***

### **Introduction**

When fish are caught or held in captivity, natural ovulation may not occur. It is therefore often necessary to induce ovulation with exogenous hormone treatments. LHRHa has been shown to stimulate oocyte maturation and ovulation in gilthead seabream (Zohar *et al*, 1988), red seabream/snapper (*Pagrus auratus*; Battaglione, 1995) and salmonids (reviewed in Donaldson and Devlin, 1996). Although recent trials have suggested that LHRHa, may induce ovulation in dhufish (Pironet and Neira, 1998, Appendix M), this remains to be proved in a controlled manner. Therefore an experiment was conducted to determine the effect of a slow-release cholesterol pellet containing LHRHa on ovulation in dhufish.

### **Methods**

During January and February of 1999 and 2000, tanks containing acclimated dhufish were drained to knee depth and fish anaesthetised with 2-phenoxyethanol (0.3ppt). An ovarian biopsy was conducted on each female to determine stage of sexual maturity. Sexually mature females (ovaries containing vitellogenic, hydrating or ovulated oocytes; oocyte diameter >400µm) were weighed and then implanted intraperitoneally with a slow-release cholesterol-based pellet containing either 0 (control; n=3) or 50 :g.kg<sup>-1</sup> LHRHa (n=10). The pellet implants were made according to Lee *et al* (1986), and contained 95% cholesterol and 5% copha oil (Appendix E). Implants were administered using a large bore needle with an internal shaft. LHRHa-treated fish weighed 6.67 ± 0.27kg, while control fish weighed 5.53 ± 0.98kg.

After treatment the fish were then placed in a 4000L tank and regular ovarian biopsies were conducted (following light anaesthesia) to assess the stage of oocyte development and to predict the time of ovulation. These were conducted at least every 24h. As soon as ovulation was detected, the fish was anaesthetised deeply for stripping. Once anaesthetised, the abdominal region of the fish was rinsed with freshwater and gently towel dried to remove traces of salt water and anaesthetic. The fish was then stripped by applying pressure along the abdomen, beginning at the front of the fish (behind the pectoral fins) and moving toward the vent. Sperm and seawater was added to the eggs, followed by gentle mixing. Sperm supply in dhufish is limiting and sperm quality is highly variable. Therefore sperm was obtained from whatever source was available including sperm stripped from freshly caught captive males, or fish caught from the wild. Water temperature was not controlled and ranged between 21.0 and 24.5°C.

From ovulation (T=0h post-ovulation fish were stripped every 24h. The trial was concluded at 96 h post capture. At each stripping, the number, viability and fertility of eggs were determined

volumetrically. Eggs were stocked into 43L incubation cones for hatching. Once hatched the number of larvae were counted volumetrically.

Paired T-tests were used to compare the first and 2<sup>nd</sup> successive ovulation from each ovulating fish, in terms of numbers of eggs produced, viability and fertilisation. Other statistical tests were not conducted due the irregularity of the data.

## Results/Discussion

Oocyte diameters at the time of treatment for all fish were between 500 and 610 $\mu$ m. In the control treatment oocyte diameters remained similar throughout the experiment (Fig A20). In the LHRHa treatment, mean oocyte diameter was 800 $\mu$ m by 48h after treatment and remained at greater than 800 $\mu$ m through to the end of the experiment.

Sixty percent of LHRHa treated fish ovulated during the 96h of the experiment, while none of the control fish ovulated. Few eggs were released on the first ovulation for each fish (<300 eggs). These small ovulations were ignored and only ovulations of more than 1000 eggs were included in the following data. Twenty percent of LHRHa-treated fish first ovulated between 24 and 48h post treatment. Thirty percent of LHRHa-treated fish first ovulated between 48 and 72h post treatment. Twenty percent first ovulated between 72 and 96h post treatment. Forty percent of fish failed to ovulate within the 96 h of the experiment. One of these died at 48h post treatment but had hydrating oocytes at death. Another fish had hydrated oocytes at 96h and ovulated 7h later (beyond the time frame of this experiment).

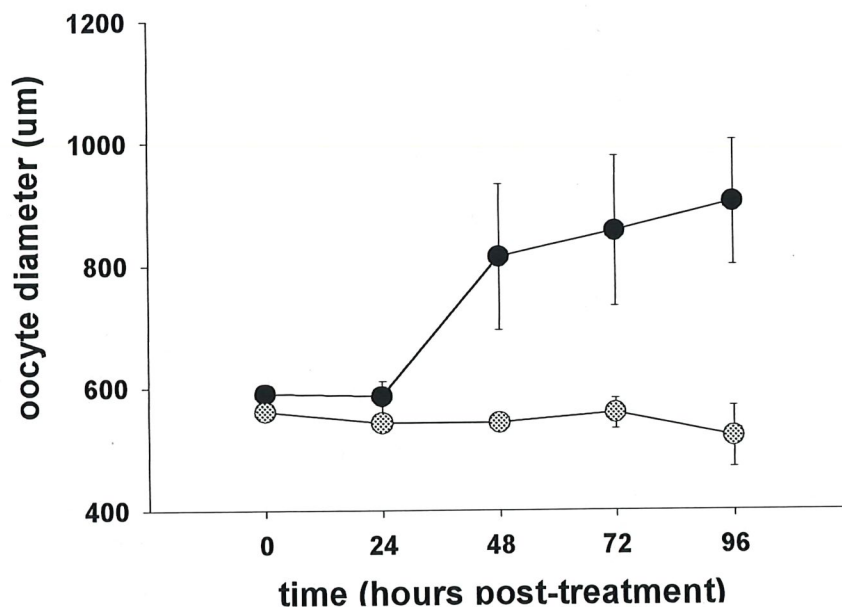

**Figure 20:** Change in mean oocyte diameter with time in acclimated female dhufish following treatment with an LHRHa slow release cholesterol pellet (50 $\mu$ g.kg<sup>-1</sup>; black circle; n=10) or a control pellet (0  $\mu$ g.kg<sup>-1</sup>; grey circle; n=3). Values are means  $\pm$  SE

Of the fish that ovulated, all fish ovulated at least twice; 42% ovulated twice and 58% ovulated three times. As the time of first ovulation varied among fish, for the purposes of further analysis, first ovulations from each fish were grouped together, as were second or third successive ovulations. At each successive ovulation an average of between 80,000 eggs and 120,000 eggs were stripped (Fig A21). The largest single ovulation was approximately 300,000 eggs, while the smallest was 17,000. The most number of eggs stripped from any one female during the experiment was 571,000 (in 3 ovulations), while the fewest number was 64,809 (in 2 ovulations). Viability of eggs in first ovulations was 95%. This decreased to 68% by the second ovulation ( $P < 0.01$ ). By the third ovulation viability was only 37%. Fertilisation success of viable eggs was low, with an average of less than 40% of the first, second and third ovulations being fertilised. Maximum fertilisation was 95%, while the lowest was 0%. Hatch was 44% in eggs from first ovulations. By the second and third ovulation, hatch was 24 and 26% respectively, almost half that of the first ovulation, however large variation prevented detection of a significant difference.

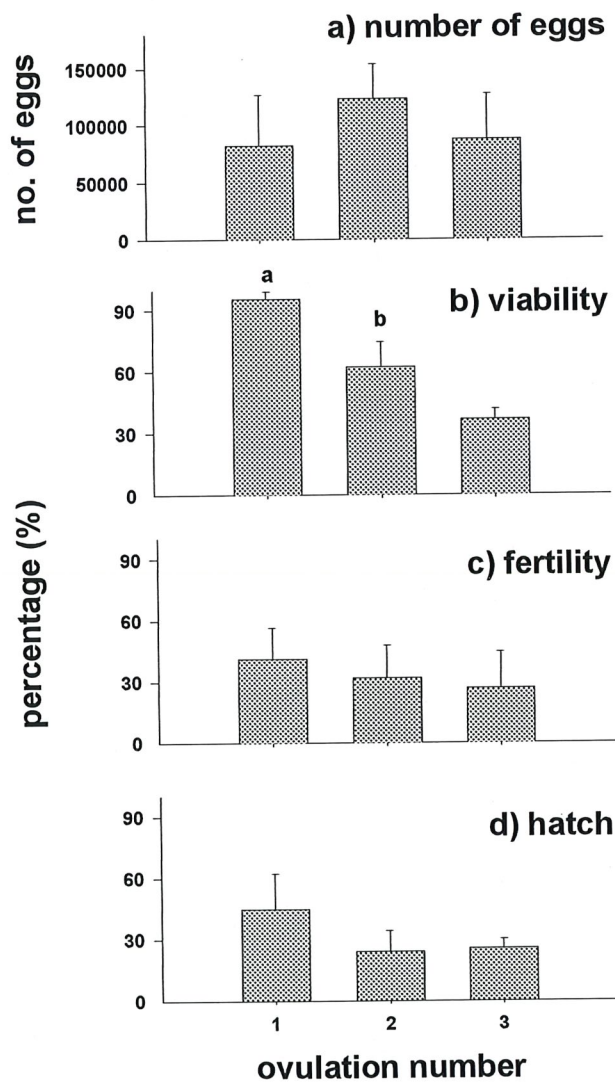

**Figure A21:** The number, % viability, % fertilisation, % hatch of eggs stripped from acclimated female dhufish following treatment with an LHRHa slow release cholesterol pellet. Different letters indicate a significant difference between first and second ovulations

Therefore LHRHa at a dose of 50:g.kg<sup>-1</sup> stimulated oocyte development in dhufish, with 60% of fish responding to the treatment, while none of the control fish did. If the fish that died and the one that ovulated a few hours after the conclusion of the experiment are considered, 80% of the treated fish ovulated. This makes the LHRHa pellet at 50:g.kg<sup>-1</sup> highly effective at stimulating ovulation in acclimated female dhufish. The time to first ovulation varied widely from 24 through to 96 h post treatment, making prediction of the time of injection impossible, without regular monitoring. The water temperature, however, was not controlled and varied between 21.0 and 24.5°C. This is likely to have influenced the latency period from treatment to ovulation. This should be addressed in further trials

All of the fish which ovulated, did so two or three times within the 96 h from treatment. Although the number of eggs produced at each successive ovulation did not appear to vary, the viability of the eggs decreased from the first ovulation to the second ovulation and presumably from the second to the third (although this was not tested statistically). This reduction in viability could be due to errors made in detecting the time of ovulation, or due to a reduction in egg quality with increasing time from treatment. Neither fertilisation (as a percentage of viable eggs) or hatch (as a percentage of fertilised eggs) decreased with successive ovulations. Fertilisation and hatch were low at each ovulation. Although fertilisation is also attributable to egg quality, sperm supply and quality in dhufish is limiting and an inadequate supply of sperm was often the primary cause of low fertilisation. When good quality sperm was available in sufficient quality and this coincided with good quality eggs, fertilisation could be as high as 95%. This emphasises the importance of continuing research in to securing a supply of good quality sperm, including refining techniques for cryopreserving sperm (Appendix L).

## References

- Battaglione, S.C.(1995). Induced ovulation and larval rearing of four species of Australian marine fish. *PhD. Thesis*, University of Tasmania. 215p
- Donaldson, E.M. and Devlin, R.H. (1996). Uses of biotechnology to enhance production. In *Developments in Aquaculture and Fisheries Science. Principles of salmonid culture* (eds W.Pennel and B.A. Barton). Elsevier, Amsterdam pp 969-1021
- Pironet, F.N and Neira, F.J. 1998. Hormone induced spawning and development of artificially reared larvae of the West Australian dhufish, *Glaucosoma hebraicum* (Glaucosomatidae). *Marine and Freshwater Research* 49: 133-42
- Zohar, Y., Pagelson, G. and Tosky, M. (1988). Daily changes in reproductive hormone levels in the female gilthead seabream *Sparus aurata* at the spawning period. In *Reproduction in Fish – Basic and Applied Aspects in endocrinology and genetics*. pp 119-125. IRNA Press, Paris.



## ***Appendix H Stimulating ovulation from dhufish caught from the wild during the spawning season***

### **Introduction**

At the ADU, fertilised eggs are normally obtained by artificially stimulating acclimated dhufish (ie caught from the wild and held in captivity for several months prior to the spawning season; Appendix G). The number and quality of the eggs obtained however is highly variable. There are many factors that may determine egg quality including nutrition and husbandry conditions (Bromage, *et al*, 1994; Pankhurst, 1998). In stress sensitive species, procedures such as routine tank maintenance, feeding or any other tank-side activity may be sufficient to induce increases in plasma cortisol levels and decreases in plasma gonadal steroid levels (Cleary *et al*, 2000a). Reduced plasma gonadal steroid levels have been shown to impair the response to hormone therapy in some species (Haddy and Pankhurst, 2000; Cleary *et al*, 2000b). Furthermore, broodstock nutrition also affects egg quality. As dhufish culture is in its infancy, little is known about broodstock nutrition. The broodstock are fed a diet of high quality fish flesh (including squid, whiting, garfish, prawns, and mullet) supplemented with vitamins and minerals (Appendix C & D). Every effort has been made to optimise this diet, however, in the absence of the facilities and resources to conduct trials, it is possible that this diet is not as good as that consumed in the wild. Therefore it is likely that the problem of poor egg quality in dhufish is a direct consequence of the culture environment.

Fish in the wild feed on a natural diet and are less likely to be exposed to chronic or acute stress during the critical period of vitellogenesis than captive fish. Therefore the use of sexually mature fish caught from the wild during the spawning season and injected with hormones at the time of capture may improve egg quality. In addition, the use of fish caught from the wild during the spawning season precludes the need to hold captive stock year round. Therefore in this pilot study, the potential of using dhufish caught from the wild during the spawning season was assessed. A variety of hormone treatments were tested: luteinising hormone releasing hormone analogue (LHRHa; injection or slow-release cholesterol pellet) or human chorionic gonadotropin (hCG; injection only). Both hCG and LHRHa are commonly used to induce ovulation in a variety of marine finfish and have also been used successfully to induce ovulation in captive dhufish (Pironet and Neira, 1998, Appendix G this volume).

### **Methods**

During the natural spawning season (December to April) between December 1998 and April 2000, dhufish were caught by handline or dropline from waters off the Perth metropolitan region. Fish were caught from depths ranging from 10 to 60m. Fish larger than 10kg were rejected as they are too difficult to handle. The swimbladder of suitably sized females was vented and the fish placed ventral side up in a foam restraint. An ovarian biopsy was conducted to determine

the stage of sexual maturity. Sexually mature females (ovaries containing vitellogenic, hydrating or ovulated oocytes; oocyte diameter > 400 $\mu$ m) were retained. Total length was measured and body weight estimated based on length to weight ratio described for dhufish caught from the wild in earlier years of this project. For convenience this data was tabulated to enable rapid conversion of weights into dose rates (eg Table A12). The fish were injected with either 200 IU hCG.kg<sup>-1</sup>, 1000 IU hCG.kg<sup>-1</sup>, >1000 IU hCG.kg<sup>-1</sup>, 100 :g LHRHa.kg<sup>-1</sup> (saline-based injection), 10ug LHRHa.kg<sup>-1</sup> (slow-release cholesterol pellet or a saline injection/blank pellet (control). LHRHa injections and pellets were pre-prepared and stored in appropriately sized aliquots in the freezer. These were kept frozen on dry ice while at sea, and thawed immediately prior to use. HCG was in the form of Chorulon®. The undiluted hCG powder was stored on ice and diluted according to manufacturers instructions immediately prior to use (see section 5.2).

**Table A12 :** Length-weight-dose conversion used at sea to determine correct dose for injection. The dose rate for hCG (10000IU.kg<sup>-1</sup>) using a stock solution of 4000IU.ml<sup>-1</sup> is given as an example.

Min FL (cm)	Max FL (cm)	Est Weight (kg)	hCG (4000IU.ml <sup>-1</sup> ) (ml)
	35.2	0.5	0.13
35.3	40.8	1	0.25
40.9	45.4	1.5	0.38
45.5	49.3	2	0.50
49.4	52.9	2.5	0.63
53.0	56.1	3	0.75
56.2	59.0	3.5	0.88
59.1	61.8	4	1.00
61.9	64.4	4.5	1.13
64.5	66.9	5	1.25
67.0	69.3	5.5	1.38
69.4	71.6	6	1.50
71.7	73.7	6.5	1.63
73.8	75.8	7	1.75
75.9	77.9	7.5	1.88
78.0	79.8	8	2.00
79.9	81.7	8.5	2.13
81.8	83.6	9	2.25
83.7	85.4	9.5	2.38
85.5	87.1	10	2.50
87.2	88.9	10.5	2.63
89.0	90.5	11	2.75
90.6	92.2	11.5	2.88
92.3		12	3.00

After treatment, fish were placed in a covered 200-250L tank supplied with oxygen and regular water exchange for transport to the ADU. At the ADU the fish were transferred to covered 4000L tanks, supplied with flow-through water and aeration. Every 24 h from capture, fish were anaesthetised lightly and an ovarian biopsy performed. If the developing oocytes were 800µm or greater, biopsies were performed more regularly to enable prediction of the time of ovulation and hence successful stripping.

Once ovulation was detected, ovulating females were anaesthetised and stripped. Sperm, collected immediately prior from live acclimated males or from wild-caught males killed and stored on ice, was used to fertilise the eggs. Egg quality was assessed by volumetrically estimating percentage viability, fertilisation and hatch.

## **Results/Discussion**

### *Capture of sexually mature females*

Seventy-two male and sixty-five female dhufish were caught. Of the females, forty-eight were immature, and nineteen were sexually mature (eleven vitellogenic and twelve hydrating or ovulated). Three of these died shortly after capture. The remainder were treated with hormones and transported back to FMC.

Following hormone treatment it is necessary for the fish to survive for at least 96 h to enable the female to respond to the hormone and ovulate. Survival of sexually mature females to 96h after capture was 72% in fish caught in water 30m or shallower and only 17% in fish caught in waters deeper than 30m. Therefore, for greatest success, sexually mature females must be caught in shallow water.

A total of forty-six fishing trips were made during the natural spawning season of the dhufish (December to April) during 1998, 1999 and 2000. The twenty-three sexually mature females caught in water depths across the full range of water depths fished in (between 10 and 60m), with twelve being caught in shallow water (<30m) and sixteen in deep water (>30m). Averaged across all fishing days, the number of mature fish caught per fishing trip in deep water, was more than twice as high from deep water than shallow water. An average of 0.88 mature fish were caught per fishing trip in deep water compared with 0.41 in shallow water. Therefore, although sexually mature fish were caught in waters above and below 30m in depth during the spawning season, it took approximately twice the fishing effort to catch fish in shallow water than the deeper water. With increased local knowledge and further understanding of the behaviour of spawning fish, the fishing effort may be reduced.

Averaged across all three years sampled, the number of mature females caught per fishing trip in shallow water was highest during December with 0.80 mature females caught per fishing trip (Table A13). From January through to April less than 0.40 mature females were caught per

fishing trip in shallow water. This data suggests that fishing for sexually mature females in shallow water should commence early in the spawning season. During late spring and summer the location of the dhufish population is associated with the annual migration of the crayfish "whites" (soft post-moult crayfish; Ron Lopresti, Revilo PTY LTD, 2000, pers com, 2000). In the Fremantle area, the crayfish normally (but not always) first appear on approximately the 7-10<sup>th</sup> December and are abundant in near shore areas until mid-January. From mid-January the "whites" begin to migrate to deeper waters. As crayfish is a common food for dhufish, it is widely believed that dhufish populations follow the "whites" to deeper water. This is consistent with data in the present study showing that sexually mature females were easier to catch in shallow water in December than in other months. It should be noted that "whites" run later in the Fremantle than they do waters to the north. Therefore fishing for sexually mature females in shallow waters to the north of Perth should begin earlier in the season.

**Table A13: Capture rate of sexually mature dhufish caught from the wild in shallow waters (<30m)**

	# trips	# mature females/trip
<b>December</b>	5	0.80
<b>January</b>	8	0.38
<b>February</b>	10	0.30
<b>March</b>	4	0.25
<b>April</b>	3	0.33
<b>Combined</b>	<b>30</b>	<b>0.41</b>

#### *Hormone induction of ovulation*

Three sexually mature females were treated with a blank pellet or injection (control). Two of these had hydrating oocytes (ie > 800µm) at capture and ovulated while being transported to the ADU (Table A14). Both of these fish were stripped at the ADU, and although one produced 18,500 eggs, no eggs were viable. The poor viability is probably due to the eggs being stripped outside of the window of peak viability, as the fish had ovulated at sea (Appendix I). These fish did not ovulate again. The oocytes of Fish # 1 decreased from 1200 µm to 600 µm by 48h post-treatment (Fig A22a). Fish # 2 died at 48h post-treatment when its oocytes were still approximately 100µm. The third control fish had oocytes of 500 µm and these did not develop throughout the experiment. This data suggests that even if ovulating females are caught from the wild, hormone treatments will be required to stimulate ovulation on successive days. In

addition, in order to utilise eggs ovulating shortly after capture, it will be necessary to be equipped to strip ovulating females at sea.

Two fish were injected with LHRHa ( $100\mu\text{g}\cdot\text{kg}^{-1}$ ). One of these had hydrating oocytes at capture, however, failed to ovulate before dying 6 h after capture (Table A14). The other fish failed to respond to the treatment and oocyte diameters remained less than  $600\mu\text{m}$  (Fig A22b). Three fish were treated with an LHRHa slow-release cholesterol pellet ( $10\mu\text{g}\cdot\text{kg}^{-1}$ ). One fish, having vitellogenic oocytes ( $592\mu\text{m}$ ) failed to respond to the treatment and oocyte diameters remained similar throughout (Table A14; Fig A22c). Two fish had hydrated oocytes at capture. One of these died within 6 h of capture and failed to ovulate in this time. The other did not ovulate and oocyte diameters gradually decreased to  $700\mu\text{m}$  by 96h post-capture. Therefore LHRHa at the

**Table A14:** The initial oocyte diameter, number of ovulations, the number of ovulated eggs and the number of viable eggs of individual female dhufish caught from the wild and treated with a control treatment, LHRHa injection ( $100\mu\text{g}\cdot\text{kg}^{-1}$ ), LHRHa pellet ( $10\mu\text{g}\cdot\text{kg}^{-1}$ ), hCG injection ( $200\text{IU}\cdot\text{kg}^{-1}$ ), hCG injection ( $1000\text{IU}\cdot\text{kg}^{-1}$ ) or hCG injection ( $>1500\text{IU}\cdot\text{kg}^{-1}$ ).

Treatment	Fish ID	Initial oocyte diameter	No. ovulations	Total no. ovulated eggs	No. viable eggs
Control	1	1124	1	18500	0
	2	1010	1	300	0
	3	500	0	0	0
LHRHa injection ( $100\mu\text{g}\cdot\text{kg}^{-1}$ )	4	506	0	0	0
	5	1050	0	0	0
LHRHa pellet ( $10\mu\text{g}\cdot\text{kg}^{-1}$ )	6	1052	1	33800	14196
	7	592	0	0	0
	8	1104	2	18000	0
hCG ( $200\text{IU}\cdot\text{kg}^{-1}$ )	9	708	0	0	0
	10	560	0	0	0
hCG ( $1000\text{IU}\cdot\text{kg}^{-1}$ )	11	659	2	200	0
	12	588	4	63250	46860
	13	1000	4	105550	44737
	14	1100	4	71365	48276
hCG ( $>1500\text{IU}\cdot\text{kg}^{-1}$ )	15	1036	4	113000	84733
	16	1200	3	17356	6729

rates tested (by injection or pellet) was not a successful treatment. Given the subsequent success of LHRHa pellet at  $50 \mu\text{g.kg}^{-1}$  in acclimated females (Appendix G), it is likely that the doses tested were too low, and so higher doses should be tested.

Two fish were treated with hCG at  $200\text{IU.kg}$ . Both of these had vitellogenic oocytes ( $550\text{-}710 \mu\text{m}$ ) at capture and failed to ovulate during the next 96h. Four fish were treated with hCG at  $1000\text{IU.kg}$ . Two of these had hydrated oocytes ( $1000$  and  $1100\mu\text{m}$ ) at capture, while two had vitellogenic oocytes ( $588$  and  $659\mu\text{m}$ ). The former 2 fish ovulated, producing a total of  $63,173$  ( $59435$  viable) and  $71365$  ( $48,276$  viable) eggs over four successive strippings. The remaining 2 fish first ovulated on days 2 and 3 after capture, one fish producing  $92,850$  ( $51945$  viable) eggs over four successive strippings, while the other fish produced only  $200$  ( $0$  viable) eggs. Two fish were treated with hCG at  $>1500 \text{IU.kg}$ . Both of these had hydrated oocytes at capture, and

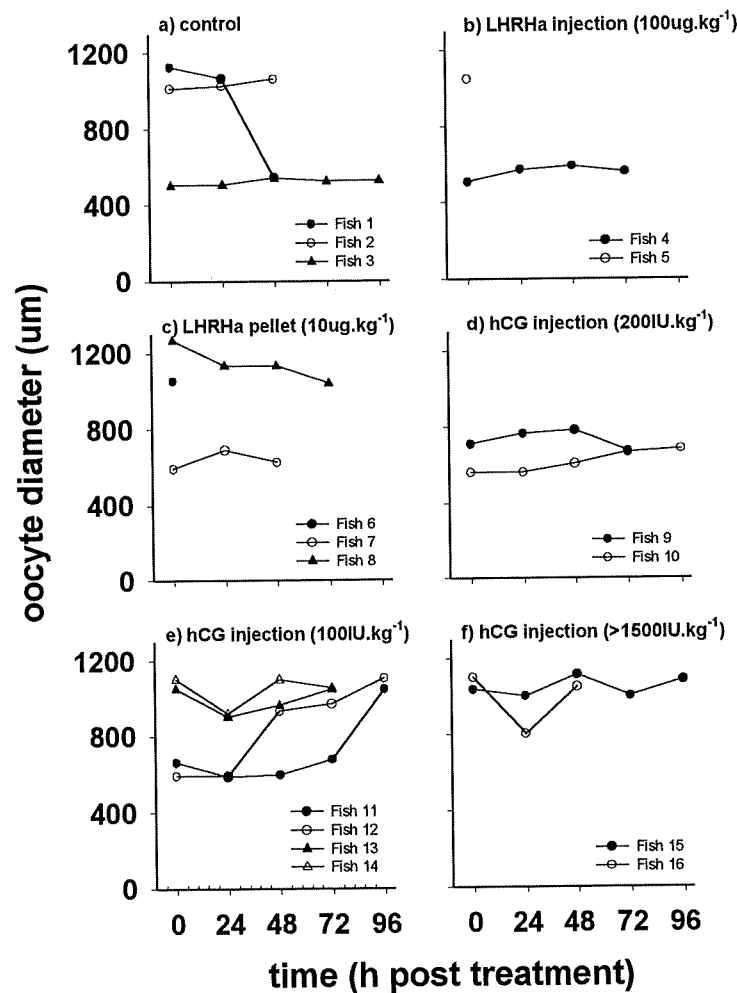

Figure A22 : Change in oocyte diameter with time from treatment of female dhufish caught from the wild and treated at capture with a) control treatment, b) LHRHa injection ( $100\mu\text{g.kg}^{-1}$ ), c) LHRHa pellet ( $10\mu\text{g.kg}^{-1}$ ), d) hCG injection ( $200\text{IU.kg}^{-1}$ ), e) hCG injection ( $1000\text{IU.kg}^{-1}$ ) or f) hCG injection ( $>1500\text{IU.kg}^{-1}$ ).

ovulated on successive days. One fish produced 142,400 (95,420 viable) eggs, while the other produced 17,356 (6729 viable) eggs. Twenty-four hours after treatment, detection of ovulation became difficult. There ceased to be a distinct class oocytes proceeding to ovulation. Instead some oocytes were beginning hydration, while others were completing it. This is reflected in the poor viability (<50%) as no matter when stripping was conducted, both old and new oocytes were stripped. Gwo *et al* (1993) reported a similar problem, stating that hCG caused generalised hydration of all oocytes in the ovary, while LHRHa caused selective hydration of oocytes at a specific stage of development. This problem, however, was not observed following treatment with hCG at the lower dose of (1000IU.kg<sup>-1</sup>).

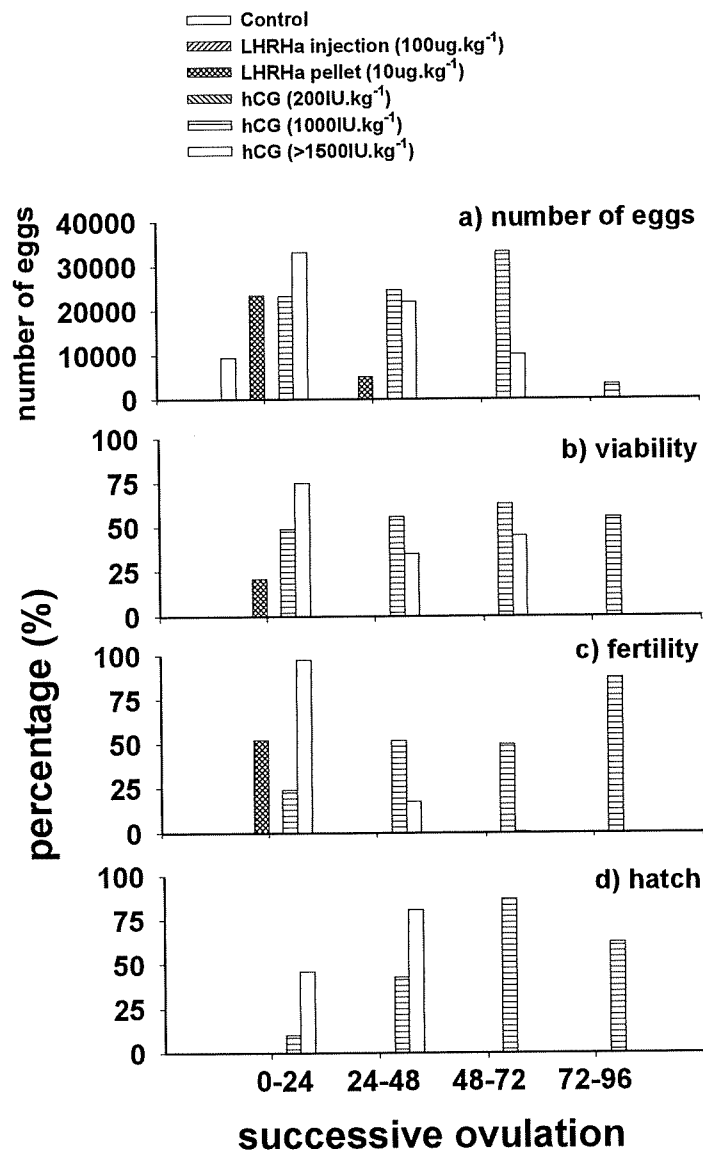

Figure A23: Mean number, % viability, % fertilisation and % hatch of eggs stripped from female dhufish caught from the wild treated with a control treatment, LHRHa injection (100µg.kg<sup>-1</sup>), LHRHa pellet (10µg.kg<sup>-1</sup>), hCG injection (200IU.kg<sup>-1</sup>), hCG injection (1000IU.kg<sup>-1</sup>) or hCG injection (>1500IU.kg<sup>-1</sup>).

Although ovulation was detected in 5 out of 6 of the treatments tested, in the majority of the treatments the fish only ovulated once and this was within 24h of capture. HCG at both 1000IU.kg<sup>-1</sup> and 1500IU.kg<sup>-1</sup>, however, stimulated multiple successive ovulations (data not shown).

The maximum mean number of eggs from any 24h period for any treatment was approximately 30,000 (1000IU.kg<sup>-1</sup>hCG at 48-72h post-treatment and >1500 IU.kg<sup>-1</sup>hCG at 0-24h post treatment; Fig A23a). The largest single ovulation was 42,400 eggs (1000IU.kg<sup>-1</sup>hCG; 16 h post treatment). The most eggs stripped from any one female was 113,000 over 4 successive stripplings (>1500IU.kg<sup>-1</sup>hCG). Mean viability ranged from 0 to 75% (Fig A23b). Mean fertility (as a percentage of viable eggs) ranged from 20 to 95% \*Fig A23c). Mean hatch (as a percentage of fertilised eggs) was highly variable with mean hatch being between 0 and 90% (Fig A23d). Therefore the number and quality of the eggs produced was highly variable. HCG at 1000IU.kg<sup>-1</sup>, however, gave consistent results with the mean number of eggs being 20,000 to 30,000 and viability being approximately 50%.

Therefore fertilised eggs can be obtained from females caught from the wild during the spawning season and treated at capture with hCG at 1000IU.kg<sup>-1</sup>. The success of obtaining good quality eggs which subsequently were fertilised and hatched from dhufish caught from the wild during the spawning season is an important development in securing a reliable supply of good quality eggs. In addition to the potential negative effects of the culture environment on egg production in captive fish, maintaining broodstock year round for a short spawning season once a year is expensive (requires large tanks, labour and high quality feed) and risky. Further refinement to the techniques for obtaining eggs from fish caught during the spawning season may open the possibility to not hold captive broodstock, but rather fish each summer for broodstock. A cost-benefit analysis would need to be done to justify this. This technique also provides the possibility for establishing new ventures or recovery after disease.



**References**

- Bromage, N., Bruce, M., Basavaraja, N., Rana, K., Heilds, R., Young, C., Dye, J., Smith, P., Gillespie, M., and Gamble, J. (1994). Egg quality determinants in finfish: the role of overripening with special reference to the timing of stripping in the Atlantic halibut *Hippoglossus hippoglossus*. *Journal of the World Aquaculture Society* 25: 13-21
- Cleary, J.J., Pankhurst, N.W. and Battaglione, S.C. (2000a). The effect of capture and handling stress on plasma steroid levels and gonadal condition in wild and farmed snapper, *Pagrus auratus* (Sparidae). *Journal of the World Aquaculture Society* in press
- Cleary, J.J., Battaglione, S.C. and Pankhurst, N.W. (2000b). Capture and handling stress affects the endocrine and ovulatory response to exogenous hormone treatment in snapper, *Pagrus auratus* in review
- Gwo, J.C., Strawn, K., Arnold, C.R. (1993). Induced ovulation in Atlantic croaker (sciaenidae) using hCG and an LHRH analog: a preliminary study. *Theriogenology* 3: 353-361
- Haddy, J.A. and Pankhurst, N.W. (2000) The efficacy of exogenous hormones in stimulating changes in plasma steroids and ovulation in wild black bream *Acanthopagrus butcheri* is improved by treatment at capture. *Aquaculture* in press
- Pankhurst, N.W. 1998. Reproduction. Pages 1-26 in. K. Black and A.D. Pickering editors. *Biology of Farmed Fish*. Sheffield Academic Press, Sheffield.
- Pironet, F.N and Neira, F.J. 1998. Hormone induced spawning and development of artificially reared larvae of the West Australian dhufish, *Glaucosoma hebraicum* (Glaucosomatidae). *Marine and Freshwater Research* 49: 133-42

## **Appendix I     *Determining the window of post-ovulatory viability***

### **Introduction**

All externally fertilising species have a window of post-ovulatory viability after which there is a time dependant decline in egg viability (reviewed in Bromage *et al*, 1994). The period of peak fertility varies among species, from several hours (eg snapper *Pagrus auratus*; Hobby and Pankhurst, 1997) to several days to weeks (eg rainbow trout; Bromage *et al*, 1994). Reliable stripping of good quality eggs is dependent on a correct estimate of the length of this window, for the species in question. The length of the window of postovulatory viability for dhufish is unknown. The capacity to accurately estimate this window is beyond the scope of this project, as it would require large numbers of fish. Nevertheless, an experiment was conducted to gain an indication of the length of the window viability of dhufish oocytes.

### **Methods**

Six captive dhufish were treated with a slow release cholesterol pellet containing LHRHa at 50:g.kg<sup>-1</sup> (Appendix E). Each fish was then placed in a 4000L tank and checked regularly for ovulation by ovarian biopsy. As soon as ovulation was detected (eggs flowing freely; T=0 h post-ovulation), a portion of the eggs were stripped. Eggs were collected and mixed with sperm stripped from a captive male (if available). Sperm was stripped prior to stripping the female at 0h and stored in a syringe on ice for later strippings. Seawater was added and the eggs were gently mixed to disperse the sperm. Egg quality was determined by taking a sample of eggs in a petri dish filled with seawater and examining them under a dissecting microscope to determine the percentage of eggs which were round, clear and buoyant. Two hours after adding the sperm, fertility was assessed by recording the percentage of eggs undergoing cell division. From T=0 h post ovulation, the fish were anaesthetised, and stripped as above every 3 h for 9h, or until fertilisation was less than 5%. Water temperature ranged between 21.5 and 23°C.

### **Results/Discussion**

The mean percentage of round, clear, buoyant eggs was 75% at the time of ovulation (0h; Fig A24). By 3h after ovulation, this was less than half, with 40% of eggs being round clear and buoyant. The mean percentage of round clear and buoyant eggs further decreased to be less than 10% by 9h post ovulation. Due to an unreliable supply of sperm from male dhufish, sperm was only available to fertilise eggs from three females. Mean fertilisation success was 70% at ovulation. By 3h post-ovulation, 55% of eggs were fertilised and by 6h, only 35% of eggs were fertilised. By 9h post-ovulation fertilisation was virtually 0%.

The window viability in dhufish appears to be short. In a similar study on snapper, *Pagrus auratus*, fertilisation fell below 50% between 6 and 9 h post ovulation (Fig A24; Hobby and

Pankhurst, 1997). In the current study, the percentage of round, clear and buoyant eggs was less than 50% before 3h post ovulation, and fertilisation was less than 50% shortly after 3h. In the present study sperm was stripped prior to stripping the female for the first time, and stored in a syringe for use at later strippings. This was done as dhufish produce very small amounts of sperm (<1ml at any one time) and this was the only way of ensuring sperm was available for the latter strippings. This method, however, opens up the possibility that the decline in fertilisation may be at least partly affected by a decline in sperm quality in the 9 h from stripping. The fact that the percentage of round clear and buoyant eggs decreased concomitant with fertilisation, however, suggests that this is not the case. The short window of viability for dhufish means that care must be taken in induced ovulation and stripping protocols to accurately detect the time of ovulation and to strip as soon as possible after.

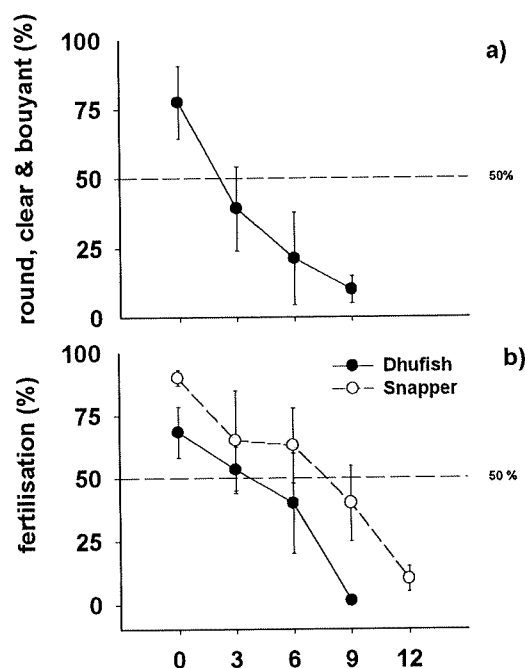

**Figure A24:** The percentage of a) round, clear and buoyant eggs and b) percentage fertilisation of eggs stripped from ovulated dhufish at 0, 3, 6, 9 and 12 h after ovulation (n=3-6; black circles). The percentage fertilisation of eggs stripped from snapper, *Pagrus auratus*, at 0, 3, 6, 9, and 12h after ovulation is presented for comparison (clear circles; from Hobby and Pankhurst, 1997). Values are means  $\pm$  SE

## 1. References

- Bromage, N., Bruce, M., Basavaraja, N., Rana, K., Heilds, R., Young, C., Dye, J., Smith, P., Gillespie, M., and Gamble, J. (1994). Egg quality determinants in finfish: the role of overripening with special reference to the timing of stripping in the Atlantic halibut *Hippoglossus hippoglossus*. *Journal of the World Aquaculture Society* 25: 13-21
- Hobby, A. and Pankhurst, N.W. (1997). Post-ovulatory egg viability in the snapper *Pagrus auratus* (Sparidae). *Marine and Freshwater Research* 48:385-9

## Appendix J *The effect of LHRHa implant on acclimated males*

### Introduction

Although male dhufish can spermiate in captivity if given sufficient acclimation time, sperm supply is currently limiting the success of the artificial propagation program for dhufish. Only the dominant males will spermiate in any particular tank and the volume of sperm produced is normally less than 1ml. Although there is some indication that the most beneficial treatment is a low dose slow-release LHRHa pellet, this information is somewhat anecdotal and it remains to be tested in a controlled manner. Therefore this experiment was conducted to examine the effect of an LHRHa slow-release pellet on the volume of sperm produced and sperm viability

### Methods

Twenty male dhufish were caught from the wild and acclimated in a number of 20,000-L tanks at the ADU; each tank containing from 2 to 6 males and up to 5 females. During three successive spawning seasons (December – April; 1997/1998, 1998/1999 and 1999/2000) tanks were drained to knee depth and the fish herded into a crowd where they were anaesthetised with 2-phenoxyethanol (3ppm) according to standard practice at the ADU. The abdomen of the fish was rinsed in fresh-water to remove salt-water and anaesthetic residues. The fish were then stripped by applying pressure along the abdomen toward the vent. All sperm released was collected in a sterile hypodermic syringe and stored on ice. Each fish was then weighed, measured and implanted with a slow-release cholesterol pellet containing either 0 or 10 :g LHRHa.kg<sup>-1</sup> (Appendix E). The fish were then released into 4000L tanks (2-3 fish per tank; 1 treatment per tank) where they remained undisturbed until Day 3 post-implant. On day 3 and 6

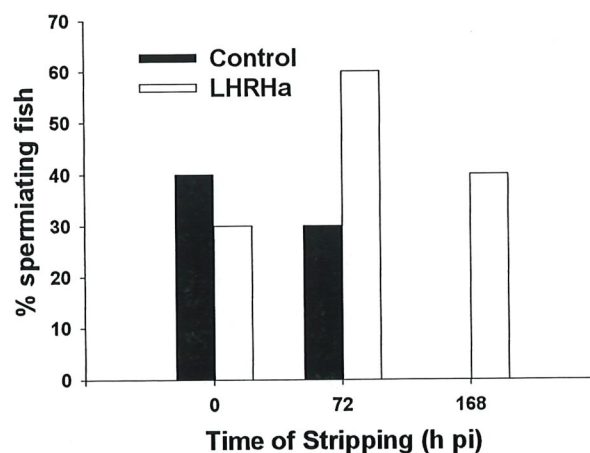

Figure A25: The proportion (%) of dhufish males spermiating 0, 72 and 168h following treatment with a slow release cholesterol pellet containing either 0 or 10  $\mu\text{g.kg}^{-1}$  LHRHa. n= 10

post-implant, each tank was drained and the fish anaesthetised, and stripped as above, before being returned to the same tank. For all sperm collected, sperm volume, and activity were determined.

## 1. Results/Discussion

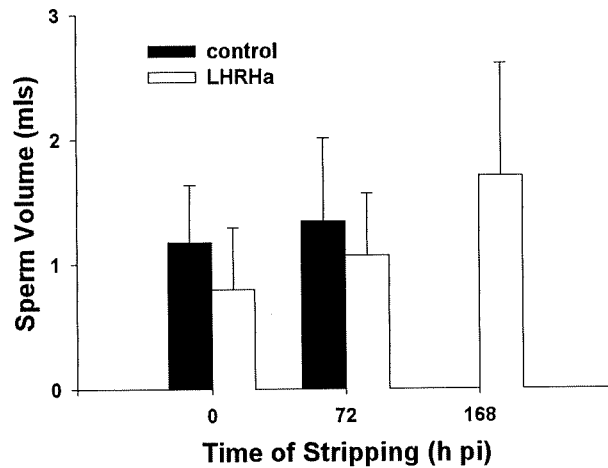

Figure A26: Volume of sperm stripped from dhufish males at 0, 72 and 168h following treatment with a slow release cholesterol pellet containing either 0 or 10  $\mu\text{g}\cdot\text{kg}^{-1}$  LHRHa.  $n=10$ . Values are means (excluding non-spermiating fish)  $\pm$  SE.

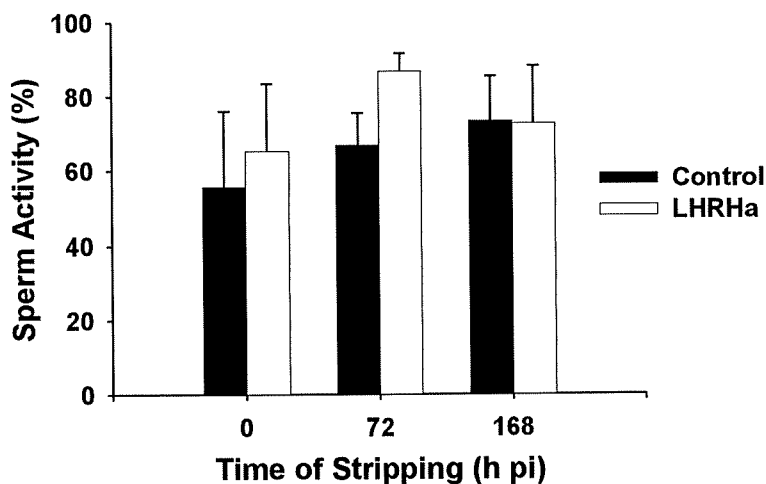

Figure A27: Activity of sperm stripped from dhufish males at 0,72 and 168h following treatment with a slow release cholesterol pellet containing 0 or 10 $\mu\text{g}\cdot\text{kg}^{-1}$  LHRHa.

At the first stripping, 40% of control-treated fish and 30% of LHRHa-treated fish could be stripped (Fig A25). By 72h post-treatment, the number of spermiating LHRHa-treated males had doubled to 60%, while in control fish it had decreased slightly to 30%. By 168h post-treatment, all control fish had ceased spermiating, while of the LHRHa-treated fish, 40% continued to spermiate

At the time of treatment, both control and LHRHa-treated fish produced an average of between 0.75 and 1 ml of sperm (non-spermiating fish excluded; Fig A26). A similar volume of sperm was produced by 72h post-treatment in both treatments, with an average of around 1ml being produced in both control and LHRHa treatments. By 168h post-treatment, the mean volume of sperm stripped from LHRHa-treated males remained at greater than 1ml, while no sperm was produced by control fish. The mean volume of sperm stripped at 168h from LHRHa-treated fish was approximately twice that stripped at 0h, although not significantly different. The activity of sperm produced by fish in both treatment groups, and at each time was between 50 and 90% (Fig A27). There was no effect of treatment or on the timing of stripping.

Therefore, stress of repeated episodes of capture, handling and stripping caused a decrease in the number of fish producing sperm by 168 h post-implant. The volume of sperm from these fish was similar, as long as some fish were spermiating. Treatment with LHRHa at  $10\mu\text{g}\cdot\text{kg}^{-1}$  maintained spermiation with a similar percentage of fish spermiating at 0 and 168h post-treatment. The volume of sperm produced from LHRHa-treated fish appeared to increase from 0 to 168h, however, large variation precluded detection of significant differences. The activity of the sperm (used here as a measure of sperm quality) was not affected by stress, indicating the action of stress on male reproduction is on whether they spermiate or not, rather than sperm quality. Sperm activity, however, is a crude measure of sperm quality and so the effect of stress on fertilisation success of sperm and embryo quality still needs to be addressed. The use of LHRHa to maintain sperm production throughout the stress episode did not compromise activity of the sperm, adding support for its use to help overcome problems of sperm supply in captive dhufish.

Since conducting this experiment, problems have been experienced in the use of LHRHa to promote spermiation in captive dhufish. Although sperm activity is usually quite high (>70%) in fish stimulated by a LHRHa pellet, the activity rapidly deteriorates with time. "Natural" sperm can usually be stored a syringe for many hours, and often even for several days. "LHRHa-induced" sperm however is usually less than 10% active within a few hours. The longevity of sperm was not tested in the present study, however, this issue needs to be addressed before treatment with an LHRHa pellet can be recommended as a reliable means of securing sperm supply from captive dhufish.

## **Appendix K    *Collection of sperm from different sources***

### **Introduction**

Sperm supply in dhufish limits the success of artificial propagation of the species. Captive male dhufish only produce a small amount of sperm compared to many other commonly cultured species. Recently techniques for cryopreserving dhufish sperm have been developed with some success. This technology, once refined, would enable a stock of cryopreserved sperm to be established for use when required. The limitation in sperm supply from captive males, however, means that there is little sperm available in the hatchery to conduct the research and in the longer term to establish a stock. Therefore, dhufish sperm will need to be obtained from fish from the wild. The simplest/cheapest way of obtaining sperm from wild-caught dhufish is to collect testes from fish at the fish market, prior to processing. Another source is to obtain fish from recreational fishermen. This study was conducted to compare the efficacy of sperm collected from fish at the fish markets and fish caught by recreational fishermen with sperm stripped from live captive male dhufish.

### **Methods**

Sperm was collected from captive males at the ADU ("Captive"), fish from the fish market ("Market") or from fish from recreational angling competition ("Competition").

"Captive": Fresh sperm was stripped from males being held at FMC and collected in a sterile syringe and stored on ice. Activity was measured by viewing sperm mixed with salt water under 40x magnification and determining the percentage of sperm moving. The time from stripping the sperm until measuring activity was less than 1h.

"Market": Testes were collected from dead fish at the fish markets. The fish had been dead for up to 72 h and stored on ice. The testes were placed in a plastic bag and stored on ice for transport to the ADU where activity was measured as above. The time from removal of the testes until measurement of activity was less than 24h.

"Competition": Testes were collected from fish caught by recreational fishermen at a fishing competition. The testes were stored on ice and the activity was measured up on return to the ADU (as above). The time from removal of the testes until measuring activity was less than 5h.

### **Results/Discussion**

Sperm stripped from captive males was significantly more active than sperm stripped from the testes of dead Competition and Market males (93%, 64% and 27% respectively; Figure A28). This difference is probably due to the delay from death until testing the activity of the sperm. Although the exact time is not known, this may have been as great as 97 h for Market fish, and



16 h for Competition fish. In contrast, for Captive fish there was a delay of less than 1 h. It is also possible, however, that the extra steps of removing the testes, and storing on ice might have affected the activity. Although not significantly different, the mean activity of sperm obtained from the Market fish was less than half that of sperm obtained from Competition fish (27 c.f. 64%). This again is likely to be due to the difference in time delay for Market and Competition fish.

These results suggest that the best source of sperm is live captive fish. It is likely that wild-caught fish stripped live, immediately following capture would yield similarly good sperm. For the purposes of cryopreservation it would be necessary to complete cryopreservation at sea to achieve optimal results. This would be logistically difficult but not impossible. In the absence of sperm stripped from live males, sperm stripped from the testes of males soon after death would be a suitable alternative. In the present study, testes were removed from the fish and stored in plastic bags on ice. There is anecdotal evidence to suggest that leaving the testes inside the dead fish, and storing the whole fish on ice may better preserve the sperm quality.

	Time Delay (h)		
Time from death until removal of testes	<72	<10	na
Time from removal of testes to measuring activity	<24	<5	na

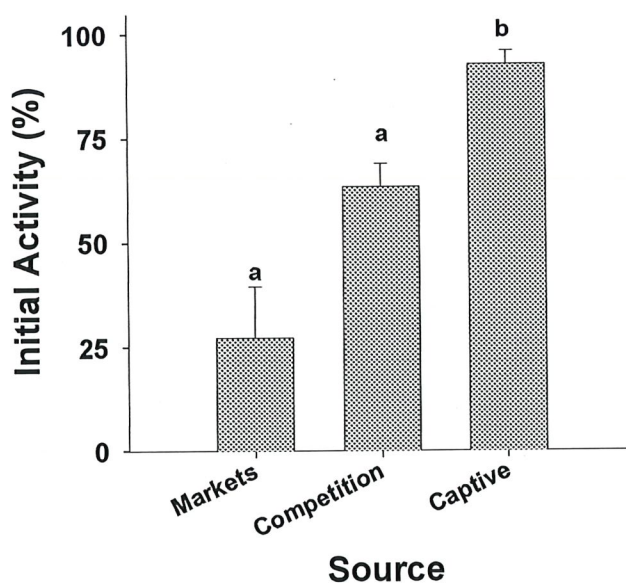

**Figure A28:** Activity of sperm, collected from a variety of sources: 1) testes removed at fish markets (Markets; n=9); 2) testes removed following an angling competition (Competition; n=17); and 3) sperm stripped from live fish (Captive, n=9). Values are means + SE. Different letters show significantly different Tukey groupings among sources.

## **Appendix L    Cryopreservation of Dhufish Spermatozoa**

Author: Tahryn Mackrill

This report was written in partial fulfilment of the Industry Practicum component of the Bachelor Degree of Marine Science, School of Environmental Science, Murdoch University

### **ABSTRACT**

The dhufish, *Glaucosoma hebraicum*, is a highly valued fish species, with great potential in aquaculture. Many problems are associated with the breeding of this species in captivity, including particularly low semen availability compared to other species. The cryopreservation of dhufish semen is a technique with potential to overcome this problem.

Semen from dhufish was preserved using two different diluents: 1) Ringers, DMSO and glycerol, and 2) Ringers and glycerol. This was to determine if the two diluents would have a significant impact on the outcome of cryopreservation. The effect of these diluents on dhufish spermatozoa was not detrimental, although the rate of diluent addition was found to influence sperm activity.

Diluted semen was frozen in 1.2mL cryogenic vials or in 0.25mL straws to determine if the storage vessels would influence the success of cryopreservation. The cryogenic vials resulted in significantly higher activities than the straws.

Overall, a fast freeze rate was compared to a slow freeze rate to determine if this would affect the outcome of cryopreservation. It was evident that a fast freeze rate resulted in higher activities than the slow freeze rate.

To compare the technique for cryopreserving spermatozoa, black bream (*Acanthopagrus butcheri*) and pink snapper (*Pagrus auratus*) trials were also conducted. The snapper spermatozoa were more robust than both black bream and dhufish spermatozoa.

## ACKNOWLEDGMENTS

Firstly and foremost, I would like to thank my industry supervisor, Dr Jennifer Cleary, for her endless patience, willing assistance, encouragement and friendship throughout the course of this project. Without her knowledge and guidance, I would have been lost.

Secondly, I wish to thank my academic supervisor, Dr Jim Cummins, for his interest in my project and wisdom on cryogenics. His help to hunt down references was invaluable.

Thankyou to Greg Jenkins for organising this project, and allowing me to set up at the Fremantle Maritime Centre.

Thankyou to Anthony Aris for taking me under his wing and teaching me first hand everything there is to know about aquaculture. Without his endless help the project would never have been complete.

I must also thank the rest of the hatchery staff, for making me feel so welcome and all helping out in one way or another. Ken, Dean, Arron, Andrew, Sam, Gavin, Bruce, Craig, Mick, John and Stuart - you have all been fantastic. Thanks also to Wayne, for sharing his office.

A big thankyou to the members of the MAAC and the Busselton Fishing and Angling Club, for allowing me to collect my fish samples and set up my endless amount of equipment.

Thankyou also to the staff at Sealanes and Festival Fish, for allowing me to collect samples and set up equipment.

Thankyou to Ron Lopresti, the best dhufish fisherman in WA, and his deckhand Ousi. The experience I gained from our fishing expeditions was priceless, and I'm now addicted to fishing forever.

Finally, thankyou to my family and friends, for showing interest, support and understanding.

## Introduction

The Dhufish, *Glaucosoma hebraicum* (of the family Glaucosomatidae), is endemic species to the south west of Australia. It has a limited distribution from Koks Island at Shark Bay, southwards to Cape Leeuwin (McKay 1997). They are carnivorous, bottom dwelling fish found mostly in reefs submerged under 30 meters or more of water (Abord 1986, Ashby 1996). In the wild, dhufish have a very slow growth rate, however, they can grow up to and over 27 kg (Hesp and Potter 2000).

Little is known of the biology of dhufish, and few studies have been conducted on the species. Dhufish are multiple spawners (Hesp and Potter, 2000). Their natural spawning season in the wild is between late December and April (Hesp and Potter, 2000) providing a very limited time frame for studies on reproductive biology to be conducted.

Due to its high value, the dhufish is subject to considerable fishing pressure both recreationally and commercially. The production of dhufish stocks through aquaculture is an alternative way of fulfilling commercial requirements, thereby reducing the pressure on the wild fish population. Aquaculture of dhufish also provides the possibility of restocking cultured dhufish into the oceans.

Breeding dhufish through aquaculture has proved to be a difficult task, and for many reasons. Primarily, female dhufish caught from the wild will not ovulate or spawn naturally when held in captivity. The Aquaculture Development Unit (ADU) of the Fremantle Maritime Centre are currently running a dhufish breeding program. They are hopeful that, provided conditions are optimal, the female fish bred at the centre (now 4 years of age) will begin to spawn without assistance in their broodstock tanks. This is an ongoing trial. In the absence of naturally spawning fish, hormone treatment is required. Whilst administering specific hormone doses will evoke ovulation, spawning still does not normally occur and the eggs must be manually stripped and fertilised (Cleary 1998). Work done by Dr Jennifer Cleary at the ADU has focused specifically on this problem. To begin the process of stripping and fertilisation, the eggs within the female fish must be released from the ovary into the oviduct (ie. ovulated). In order to do so, the female is treated with the hormone LHRHa (luteinising hormone releasing hormone analogue) or HCG (human chorionic gonadotropin) to induce ovulation. Once ovulation has occurred, the female is anaesthetised so that the eggs within her can be stripped manually. Semen is collected from male dhufish in a similar fashion, and is then added to the freshly stripped eggs and gently mixed. Salt water is added to activate the sperm cells and begin the process of fertilisation. With the initial problems relating to egg production overcome, the successive problems of sperm production arise.

Availability of good quality dhufish semen is often an impediment to the successful production of fertilised eggs. Male dhufish held in captivity will spermiate naturally if their time in the tank has

been sufficient for them to acclimatise to the environment (Cleary 1998). However, it has become apparent that without hormonal assistance only the dominant male in a tank (ie, the healthiest and fittest - usually the largest, unless it is ill) will produce semen. Further problems arise with the volume of semen produced by each male. A large male dhufish of approximately 9 kg will yield less than 1 mL of semen on any one day. In contrast, a small pink snapper of approximately 2 kg can yield up to 10 mL of excellent quality semen. This is directly related to testes size. A dhufish testes constitutes only 0.1% of the total body weight as opposed to 5-10% of the body weight in a snapper (Hesp and Potter, 2000).

Although hormone induced males produce larger volumes of semen, and with more than one male in a tank spermiating at a time, the semen produced tends to be less viscous than naturally produced semen. The sperm cells do not appear to remain active for a long enough period of time, suggesting that they are of poorer quality. Further studies will be conducted in the future in an attempt to refine the hormone induction technique. However, due to the small volume of semen available in wild-caught fish, it is unlikely that hormone therapy will completely overcome limitations in semen supply.

Cryopreservation is a technique that could help to overcome the problems associated with limited semen supplies. Cryopreservation is essentially the "long-term preservation of biological material in a frozen but viable form at ultra-low temperatures, usually below  $-130^{\circ}\text{C}$ " (Bromage and Roberts 1995). Presently, any attempts to cryopreserve fish ova have been unsuccessful.

In contrast, spermatozoa have been successfully cryopreserved for many years. The origin of spermatozoan cryopreservation dates back to 1953, with Blaxter's work on herring spermatozoa. Since then, cryopreservation has developed and is now a well-established procedure. Many problems are associated with cryopreserving sperm cells, although for many of the species of fish examined, these problems have been overcome. The preservation of spermatozoa provides a great number of benefits to aquaculture. In the case of dhufish, cryopreservation technology could be used to overcome limitations in semen supply by establishing a 'sperm bank'. This would guarantee a supply to meet fertilisation requirements.

Cryopreservation, although successful in many species, has never been established for the dhufish. The fact that limited studies on any aspect of this species have been conducted makes work on them quite difficult. In previous years at the ADU, trials to cryopreserve dhufish sperm were undertaken. Success was achieved in terms of freezing and thawing the sperm, although fertilisation of eggs with the thawed sperm was unsuccessful (Cleary, Jenkins and Partridge 1999). The limited success is not surprising, considering that there are a number of factors that may affect the success of cryopreservation.

As a result, this project was conducted in an attempt to determine a successful method for cryopreserving dhufish spermatozoa. Through experimentation, the factors affecting cryopreservation of dhufish semen were explored. However, the pre-mentioned problems

associated with low semen availability for this species placed limitations on the study. Additional trials were conducted on black bream (*Acanthopagrus butcheri*) and pink snapper (*Pagrus auratus*) to determine if the efficacy of the cryopreservation technique varies between species.

The determination of an effective method for cryopreservation involved testing whether the use of different diluents and storage vessels would significantly impact the success of freezing. Two diluents were compared, one containing the cryoprotectants DMSO and glycerol, and one containing simply glycerol. The two storage vessels compared were 1.2mL sterile cryogenic vials and 0.25mL cryogenic straws.

## **Materials and Methods**

### ***Dhufish - Trial 1***

#### *Collection of Semen*

Semen was stripped from the testes of wild caught dhufish on the 8<sup>th</sup> January 2000, at the Marmion Angling and Aquatic Club (MAAC) fishing competition. The testes were removed from male dhufish several hours after death. The time of removal, length of the fish, and whether or not the fish was kept chilled (ie. on ice) were recorded. Once removed, the testes were placed in sealed plastic bags, and stored on ice until needed.

After making a small section in the testes with a scalpel, a pasteur pipette was used to take a small sample of the semen to determine the activity of the sperm. This was called the initial activity. Once an initial activity reading was taken from each sample, the scalpel was used to cut open the testes at one end. Starting from the anterior end and gently working down with smooth forceps (or fingers), the semen was stripped out and into labelled 2mL vials. The maximum volume of semen allowed in each vial was 0.4 mL (to allow for dilution - see below). Thus, multiple vials were used for each testes. The vials were kept in a stand within an ice bath so as to keep the samples continuously chilled.

#### *Determining activity*

A small sample of semen was taken using a pasteur pipette, and smeared onto a glass microscope slide. A glass cover slip was placed over the smear, and the slide was examined under a compound microscope. At this point, the sample should have been inactive, indicating that no seawater had contaminated the semen. If the sperm cells were already activated, the sample could not be cryopreserved and so no further processing was conducted. If the sample was inactive, an activity reading was taken.

To the slide containing the inactive sperm cells, a drop of seawater was added by gently lifting the cover slip, and replacing it after addition. With the seawater added, the live spermatozoa activate and will be seen swimming rapidly on the microscope slide. Any dead sperm cells can be seen as immobile dots. By examining the slide on a magnification of 40x, an approximation of the number of active cells amongst inactive cells in the field of view was taken. This was repeated at different positions on the slide to gain an approximation of the percentage of active sperm cells for the entire sample. Any sperm cells vibrating on the spot, but not swimming were not counted as active spermatozoa. Sperm activity was used to measure the quality of the semen.

#### *Processing of semen – Comparison of DMSO vs glycerol*

Once the semen was separated into vials, the diluents were added. Two diluents were trialed (Table A 15): 1) Marine Teleost Ringers (Table A16) with glycerol and 2) Marine Teleost Ringers with glycerol and dimethyl-sulphoxide (this diluent is referred to as DMSO). Approximately half of the vials from any one fish were allocated to the DMSO treatment, and the remainder to glycerol.

**Table A15: Composition of the two diluents used for diluting semen samples prior to cryopreservation.**

	Diluent	
	DMSO	Glycerol
Marine Teleost Ringers	50 mL	50 mL
Glycerol (5%)	2.5 mL	2.5 mL
DMSO (6.25%)	3.25 mL	N/A

The diluent was added in four equal portions using an automatic pipette. Each portion was equivalent to the volume of semen, so that the final ratio of semen to diluent was 1:4. The rate of diluent addition was quite rapid for this trial. During dilution, the vials were kept on ice. Between each diluent addition, the vial was gently shaken to mix the diluent with the semen. Once diluted, a small sample was taken from each vial and the activity of the sperm cells was recorded (as above). This was called the pre-freeze activity.

**Table A16: Composition of the Marine Teleost Ringers used in both diluents. Adapted from Palmer, Hogan and Barlow, 1994.**

Component	50mL Stock Solutions (in 50mL dist H <sub>2</sub> O)	Ringers Solution (vol of stock)	Final Concentration of Ringers (g/L)
NaCl	No stock	7.25 g	7.25
KCl	3.8 g	5 mL	0.38
CaCl <sub>2</sub> .2H <sub>2</sub> O	2.4 g	5 mL	0.24
MgSO <sub>4</sub> .7H <sub>2</sub> O	2.7 g	5 mL	0.27
NaHCO <sub>3</sub>	1 g	0.5 mL	0.01
NaH <sub>2</sub> PO <sub>4</sub> .2H <sub>2</sub> O	4.1 g	5 mL	0.41
D+ glucose	10.1 g	5 mL	1.01
Distilled water		975.5 mL	

#### *Cryopreservation of semen – Comparison of straws vs vials*

Two storage vessels were used: straws and vials. The diluted semen was portioned into cryogenic straws and sterile cryogenic vials to prepare for freeze. The semen was drawn into the 0.25 mL straws using a syringe with fine tubing on the end which attached firmly to the top of the straw. An automatic pipette was used to place 100 µL samples of diluted semen into the 1.2 mL cryogenic vials. Approximately half of the semen diluted in glycerol was stored in straws, and the other half was stored in vials. Semen diluted with DMSO was treated this way also.

Vials and straws were taped onto the end of a thin piece of PVC rod. A 1.5 L thermos flask was half-filled with liquid nitrogen. The samples were secured in the neck of the flask by a clamping the rod to a retort stand (Fig A29). Gradually, the rod was lowered into the liquid. An electronic thermometer was also attached to the rod, to monitor the temperature change. On average, a freeze rate of 3 to 5 °C.min<sup>-1</sup> was applied.

Once the temperature reached -50 °C, the samples were completely submerged in the liquid. They were removed from the rod and transferred to the liquid nitrogen dewar for storage (the straws were in goblets attached to the canes, and the vials were attached directly onto the cane). They were stored in the dewar for no particular length of time, until the thawing of samples was conducted.



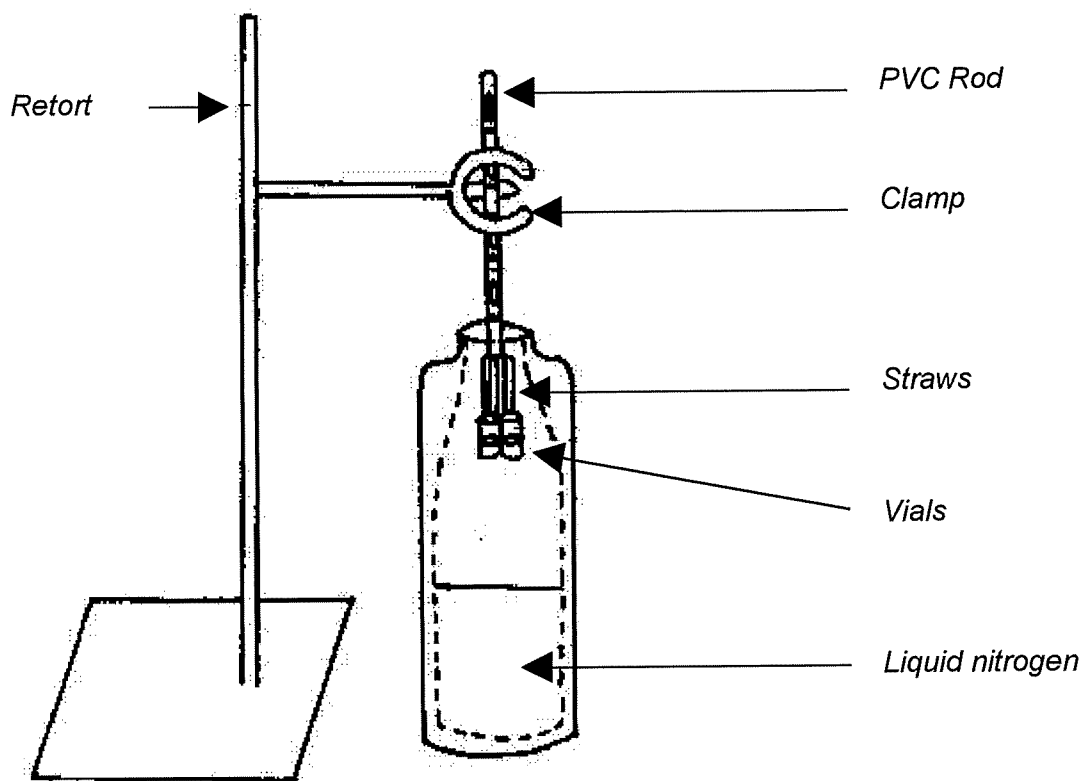

**Figure A29:** Set up of equipment used in dhufish trial 1. This was a slow freeze in liquid nitrogen vapour.

### *Thawing of semen*

The straws and vials were thawed at a range of different temperatures in an attempt to find the most successful. Thus, cold water baths as low as 20 °C and hot water baths up to 50 °C were used. Some samples were thawed at room temperature. The temperature used was recorded for each sample.

Once thawed, a slide was prepared from each sample to obtain the final activity reading for the trial. This was the post-freeze activity.

### ***Dhufish - Trials 2 and 3***

#### *Collection of semen*

##### Trial 2 – Wild-caught

This trial was also conducted at the MAAC, on the 5<sup>th</sup> February 2000 at the fishing competition. The method of collecting the semen was identical to the method used in dhufish trial 1.

Trial 3 – Captive

Unlike the first two dhufish trials, which collected semen from dead dhufish, the third trial was conducted on live fish. The semen was collected opportunistically (whenever tanks were drained) from the captive male dhufish held in the broodstock tanks at the ADU. The fish were anaesthetised using 2-phenoxyethanol, at a dose rate of 0.3 ml/L. Once anaesthetised, the fish was lifted out of the tank, rinsed thoroughly with freshwater on its abdominal area and gently towelled dry. This prevents contamination of semen with salt water and anaesthetic. By gently applying pressure along the abdomen from behind the pectoral fins, toward the vent, the semen was forced out of the vent. It was collected in 1mL or 2mL sterile syringes.

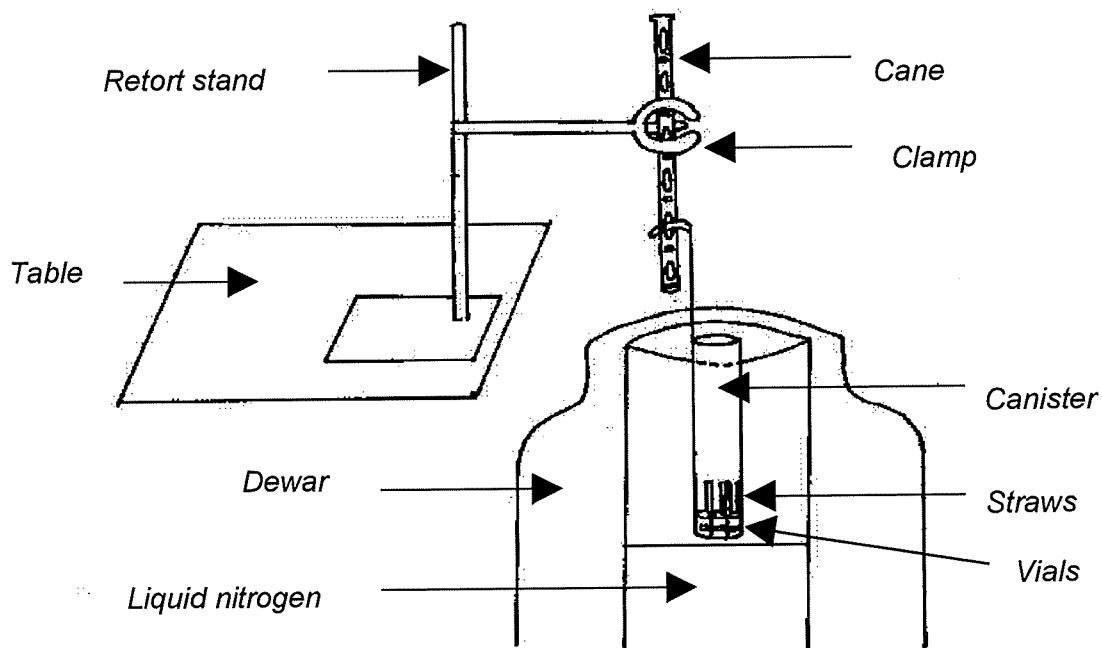

**Figure A30:** Set up of equipment used for dhufish trials 2 and 3, all black bream trials and the snapper trial. This was a rapid freeze in liquid nitrogen vapour.

*Processing of semen – Comparison of DMSO vs glycerol*

The processing of semen for both trials was almost identical to the processing in dhufish trial 1. The only variation was the rate of dilution. The addition of diluent to the semen in trial 2 was slower than for the first trial, yet no set time was allowed between each addition. However, in trial 3, the addition of diluent to the semen samples allowed a 30 second interval between successive additions.

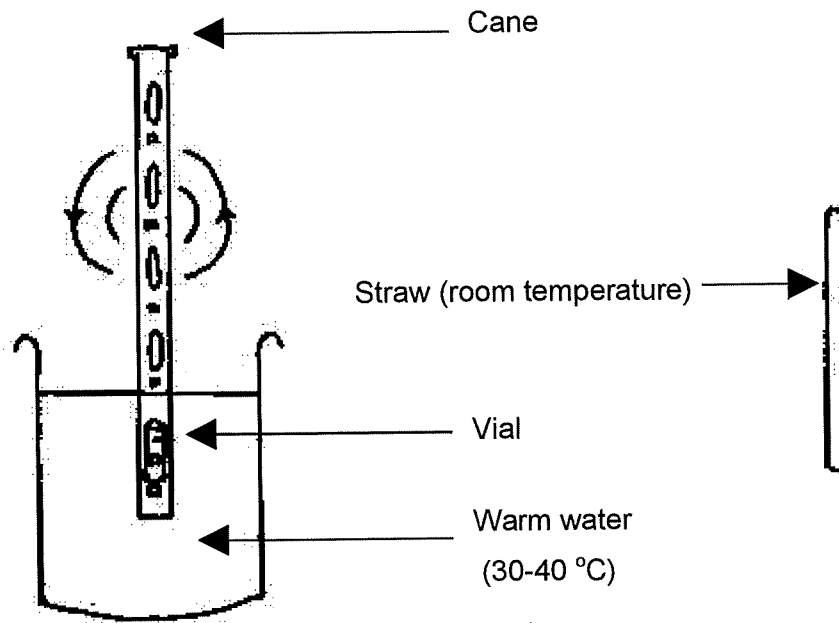

**Figure A31:** Thawing of vials and straws for dhufish trials 2 and 3, all black bream trials and the snapper trial.

#### *Cryopreservation of semen – Comparison of straws vs vials*

The portioning of samples from the vials into the straws and cryogenic vials was identical to the procedure in dhufish trial 1. However, the rate of freezing the samples was more rapid.

Rather than a slow freeze, the method chosen for cryopreserving was a rapid freeze in the liquid nitrogen vapour. A canister from the dewar was removed, and positioned within the dewar so that the base was held just above the surface level of the liquid nitrogen. The canister was kept in this place by hooking the handle through a cane held by the clamp on a retort stand (refer to Fig A30). A few vials and straws were then simply dropped into the canister, and left for 10 minutes to ensure that the freeze was complete. Due to limitations in equipment sensitivity, the rate of freeze for this method is unknown, yet the electronic thermometer indicated a drop of  $-50^{\circ}\text{C}$  in less than 30 seconds.

#### *Thawing of semen*

Rather than thawing over a range of temperatures as in dhufish trial 1, the straws and cryogenic vials in these trials were thawed at set temperatures recommended by Leung (1983). The straws were thawed for 3 minutes at room temperature. The vials were swirled in a warm water bath between  $30$  and  $40^{\circ}\text{C}$  for 1.5 minutes (Fig A31).

***Black Bream - Trials 1-4 and Snapper****Collection of semen*

The black bream and snapper semen for these trials was collected from live fish held in tanks at the ADU. The method of collection was the same as that described for dhufish trial 3.

*Processing of semen – Comparison of DMSO vs glycerol*

The processing of the semen was similar to dhufish trials 2 and 3, with 30 second intervals between successive diluent additions.

*Cryopreservation of semen – Comparison of straws vs vials*

The method of freezing the samples was the same as that described for dhufish trials 2 and 3 - a rapid freeze in liquid nitrogen vapour.

*Thawing of semen*

The thawing for all of these trials was the same as in dhufish trials 2 and 3.

**Table A17 : Summary of the varying techniques used for collecting, preparing, cryopreserving and thawing semen samples for dhufish, black bream and snapper trials.**

	Source	Dilution	Diluents	Freeze Rate	Thaw Rate	
					Straws	Vials
Dhufish Trial 1	Dead	Fast	DMSO & Glycerol	Fast	Varied room-50 °C	Varied room-50 °C
Dhufish Trial 2	Dead	Med.	DMSO & Glycerol	Slow	Room	30-40 °C
Dhufish Trial 3	Alive	Slow	DMSO & Glycerol	Slow	Room	30-40 °C
Black bream Trials 1-4	Alive	Slow	DMSO & Glycerol	Slow	Room	30-40 °C
Snapper Trial 1	Alive	Slow	DMSO & Glycerol	Slow	Room	30-40 °C

### ***Analysis of data***

For each species, the raw data was sorted into each of the four treatments being tested - DMSO with straws, DMSO with vials, glycerol with straws and glycerol with vials. For each of these treatments, the mean, standard deviation and standard error was calculated, using the average activities for initial, pre-freeze and post-freeze.

Statistics were used to make comparisons between these treatments. For these analyses, dhufish trials 2 and 3 were pooled together, due to their similar techniques. The subsequent increase in sample size increased statistical power. The same was done for all of the black bream trials, which were pooled together into one trial.

Data was analysed by ANOVA. Prior to performing ANOVA, homogeneity of variance was tested using Bartlett's test. If the variance was homogenous, no further transformations were required prior to further analysis. To test differences between diluents and vessels, a two-way ANOVA was performed on each data set (initial, pre-freeze and post-freeze activity). If no significant differences occurred between the diluents or between the vessels, and there was no interaction, the analysis was complete. If one significant difference occurred, a one-way ANOVA (t-test) was performed by pooling the data, disregarding the insignificant component. If two significant differences occurred, a comparison of means was conducted using the Tukey-Kramer HSD test. All analysis was conducted using the statistics computer package, JMP Version 3.1.1.

The Tukey-Kramer HSD test was then used to conduct a comparison of means for the mean initial, pre-freeze and post-freeze activities from each species. This test indicated any significant differences within species between each of these activities. It also indicated if any relationships between species existed. Dhufish trials 2 and 3 were treated as different trials for this analysis, in order to visualise if any difference occurred between the wild-caught and the captive dhufish. Due to the large sample size of the black bream trial (1-4 combined) compared to the other trials, 50 data entries were randomly removed prior to analysis. This created approximately equal sample sizes for each species, and increased to chance of obtaining equal variances.

## RESULTS

### *Dhufish - Trial 1*

The mean activity decreased during dilution, with initial activities of about 75% decreasing to 50-60% after dilution. The comparison of means from this trial (Fig A32) indicated that this difference was significant. The decrease during the freeze was greater, with mean post-freeze activities ranging from 0-25% only. This decrease from pre-freeze activity was significant (Fig A33).

After the addition of the diluent, the glycerol samples had significantly higher activities than the DMSO samples ( $P=0.02$ ; Fig A33). A significant difference was also indicated between the vessels. However, Bartlett's test on the one-way ANOVA indicated that variances were not homogenous. An attempt to arc-sin transform the data was made, yet the variances remained unequal. The figures in Table A18 below explain this.

**Table A18 : The range of post-freeze activities for dhufish trial 1.**

Activity Range for Post-Freeze	Frequency
0-10%	36
10-30%	1
30-50%	6
50-70%	1
70-90%	1

With the bulk of the activities occurring within the narrow range of 0-10%, the curve for the distribution of this data is not 'normal'. Since the data does not have a normal distribution, no valid analyses can be performed. This is not important however. The importance lies in the fact that the majority of samples had a post-freeze activity close to, or equal to, zero.

### *Dhufish - Trials 2 and 3 combined*

In the second trial, a significant decrease in activity occurred after the addition of diluent to the samples. This decrease occurred during the freeze also, with post-freeze activities significantly different to pre-freeze activities (Fig A34). The mean post-freeze activity for this trial was significantly higher than for trial 1.

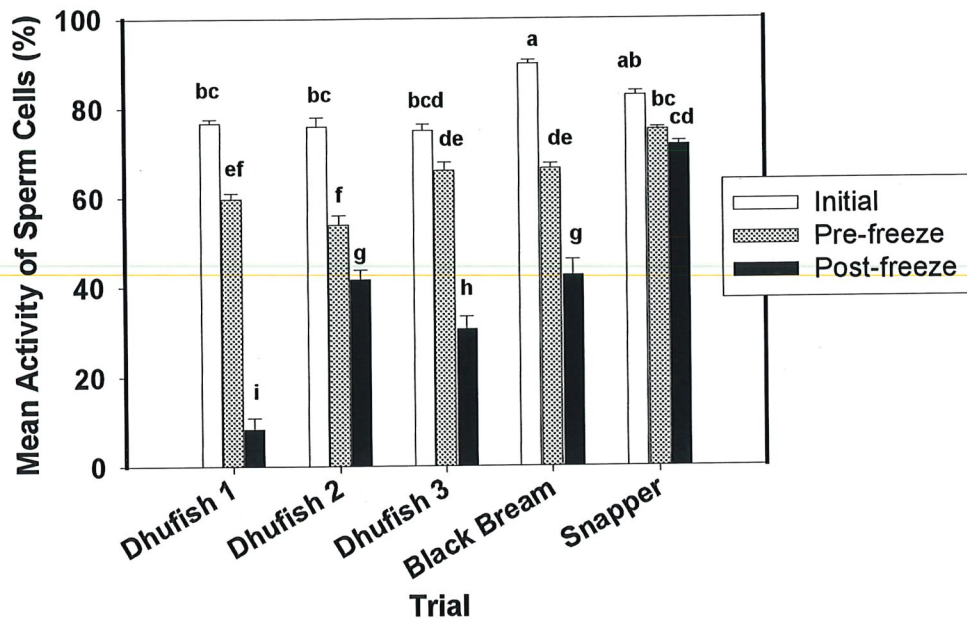

**Figure A32:** Comparison of means for initial, pre-freeze and post-freeze activities for each dhufish, black bream and snapper. Different letters indicate significantly different Tukey-Kramer HSD grouping ( $P < 0.01$ ).

The comparison of means for the third trial indicated that the dilution had no significant effect on the pre-freeze activity. However, the decrease from pre-freeze to post-freeze activity was significant (Fig A32). This post-freeze activity is significantly higher than the first trial, yet significantly lower than the second.

The combined data from dhufish trials 2 and 3 indicated that the activities of DMSO samples were higher than that of glycerol samples (Fig A34). The difference between these two diluents was significant ( $P = 0.0137$ ). A significant difference also occurred between the vessels after freezing. Once thawed, the activities of the vials were significantly higher than the activities of the straws ( $P = 0.0263$ ; Fig A34).

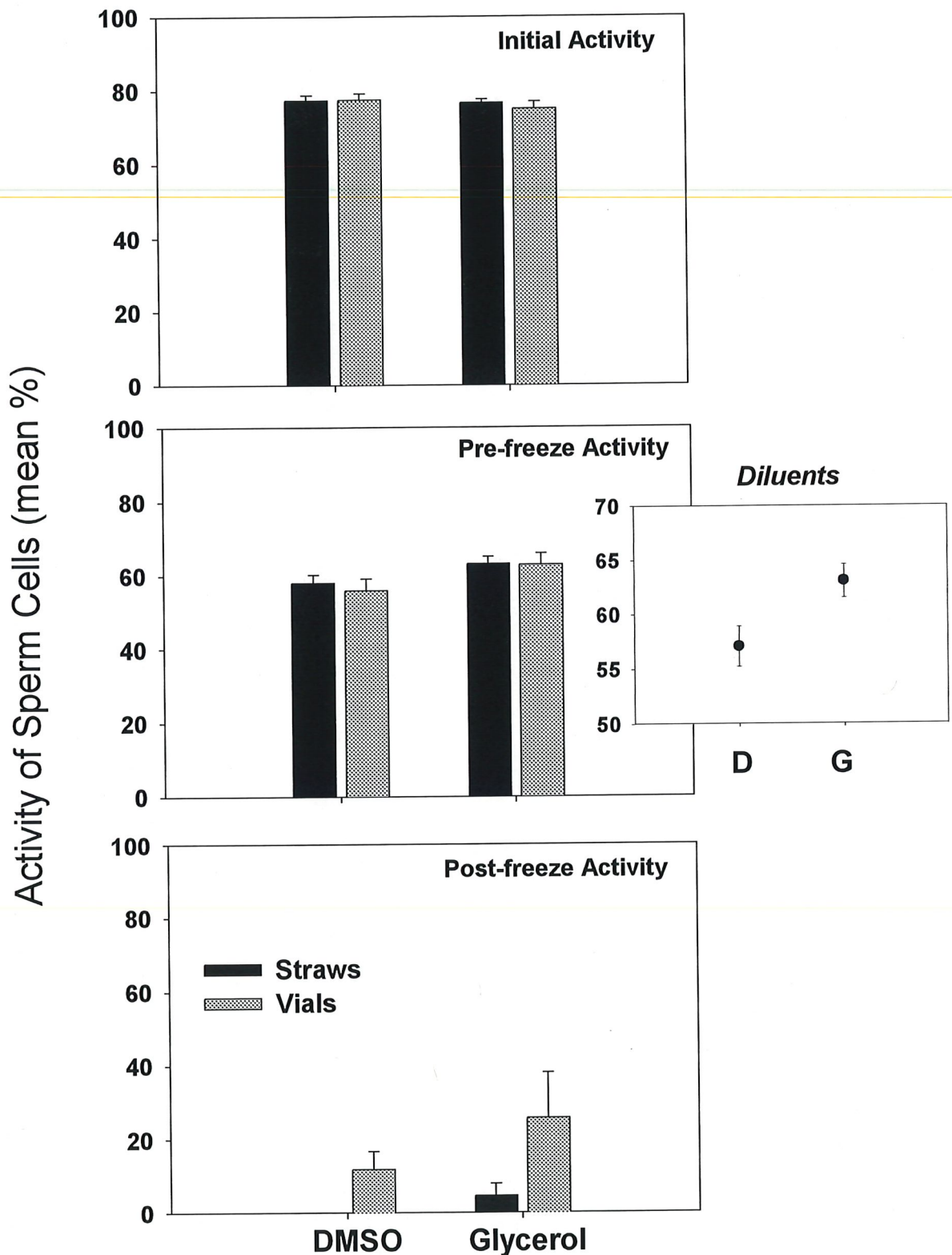

Figure A33: Mean initial, pre-freeze and post-freeze activities of the sperm cells for each treatment within Dhufish trial 1. The scatter plot illustrates a significant difference between diluents for the pre-freeze activity.



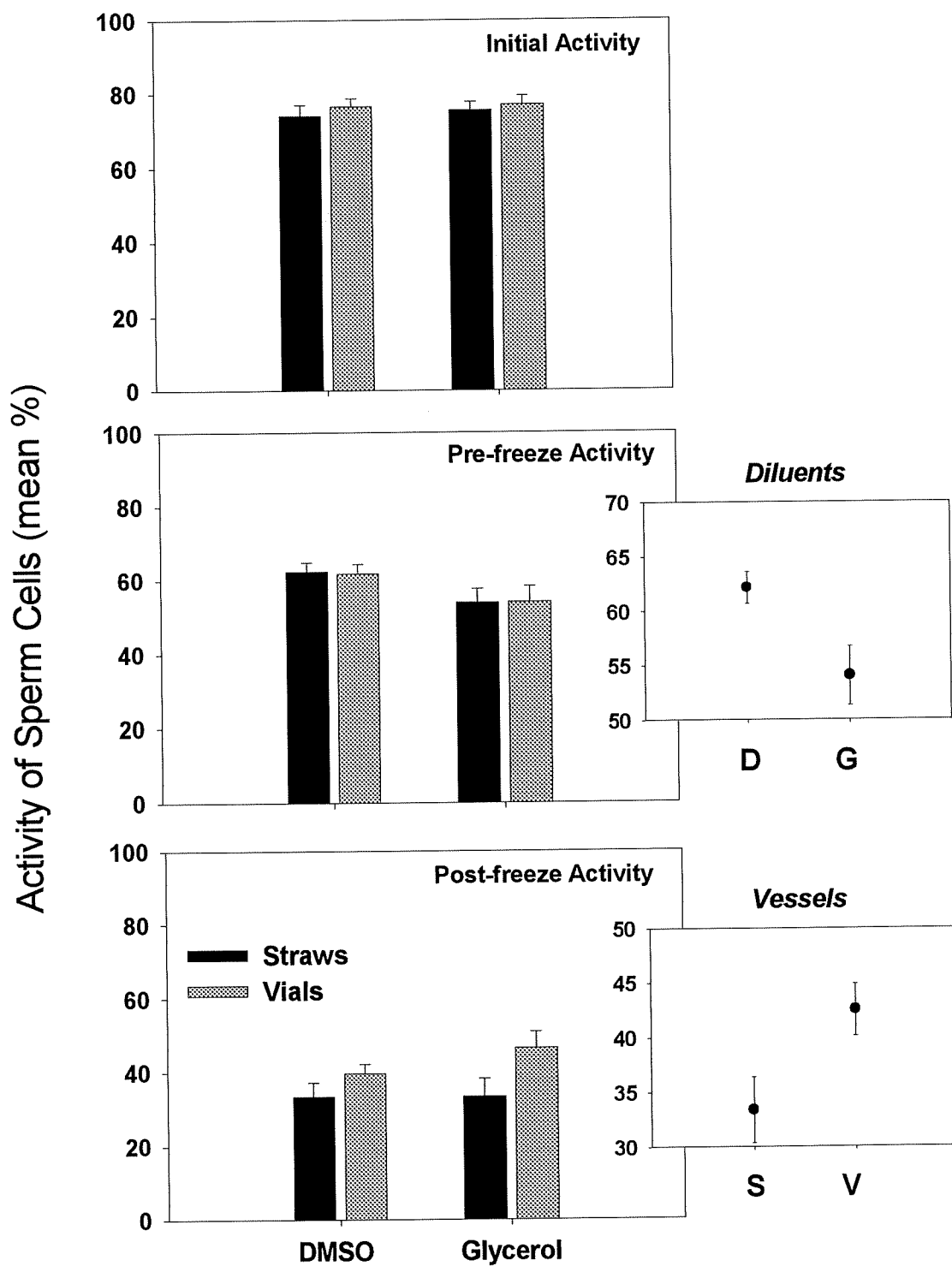

Figure 34: Mean initial, pre-freeze and post-freeze activities of the sperm cells for each treatment within Dhufish trials 2 and 3. The scatter plots illustrate significant differences between diluents for the pre-freeze activity, and storage vessels for the post-freeze activity.

***Black Bream - Trials 1-4 combined***

The mean activity of the sperm cells after dilution was significantly lower than the initial activity (Fig A32). The decrease during freeze was also significant, with pre-freeze activities of above 63% dropping to 30-55% at post-freeze. The mean post-freeze activity was the same as the post-freeze activities in dhufish trial 2.

The two diluents did not result significantly result in different activities after dilution. The comparison of means for the different treatments at post-freeze (Fig A35) illustrates that vials were significantly higher than straws with DMSO as a diluent. Yet, they are not significantly different with glycerol.

***Snapper - Trial 1***

The comparison of means for this trial indicated that no significant decreases in activity resulted from dilution or during the freeze (Fig A32). However, a significant decrease in initial activity to post-freeze activity was apparent.

The only significant difference that occurred between treatments was between the two diluents. DMSO samples had significantly higher activities than glycerol samples after dilution ( $P < 0.0001$ ; Fig A36).

***Comparison between species***

The mean initial activities for the dhufish trials and the snapper trial were the same. The black bream trial however, had a mean initial activity significantly higher than all of the dhufish trials (Fig A32).

The mean pre-freeze activities for the snapper trial and dhufish trial 3 were not significantly affected by the addition of diluents. However, dhufish trials 1 and 2 and the black bream trial showed a significant decrease in activity when diluents were added.

The mean post-freeze activity for the snapper trial was significantly higher than for all other trials. The mean post-freeze activities for dhufish trial 2 and the black bream trial were the same. Dhufish trial 1 had a dramatically low post-freeze activity, which was significantly different from all the others.

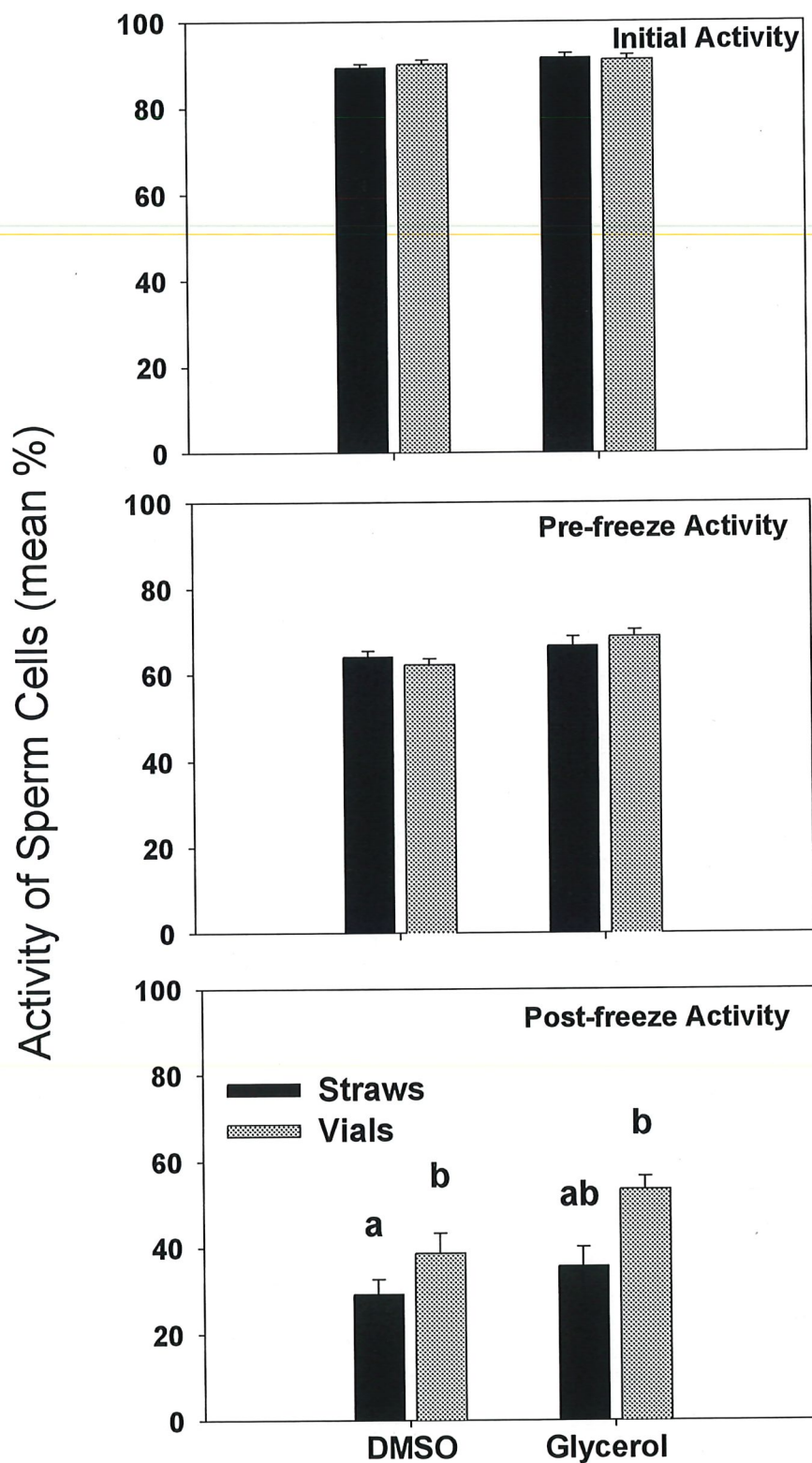

Figure A35: Mean initial, pre-freeze and post-freeze activities of the sperm cells for each treatment within the black bream trial. The different letters on the post-freeze activity graph indicate significant differences.

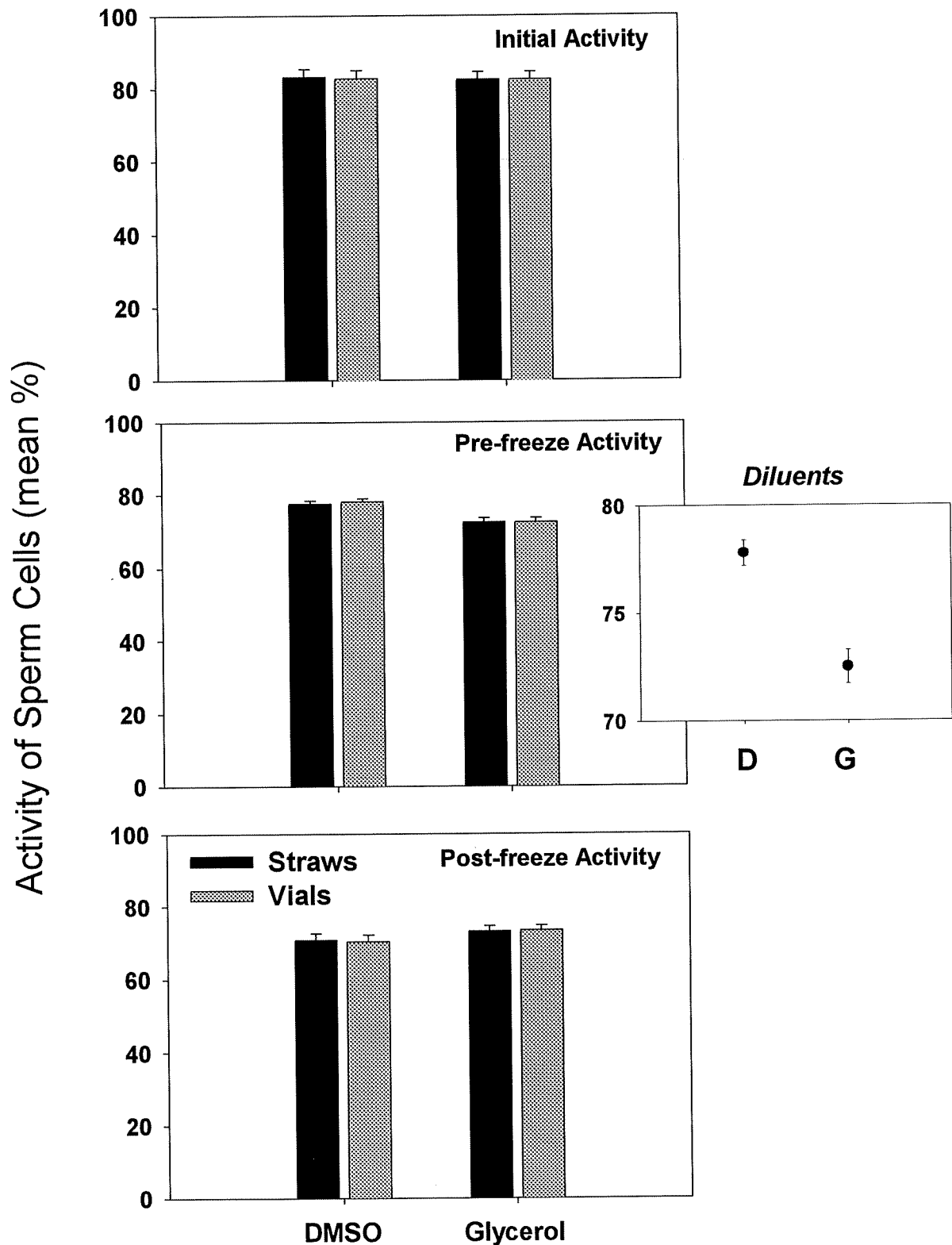

Figure A36: Mean initial, pre-freeze and post-freeze activities of the sperm cells for each treatment within the snapper trial. The scatter plot illustrates a significant difference between diluents for the pre-freeze activity.

## DISCUSSION

### *Dilution*

#### *Osmotic shock*

The dramatic decrease in activity that occurred after dilution from initial activity to pre-freeze activity in all trials (except the snapper) can be partially attributed to osmotic shock. The diluents added to the semen samples both contained Marine Teleost Ringer solutions, as well as either DMSO or glycerol, which function as cryoprotectants. If these solutions are added to sperm cells too rapidly, the sudden change in ionic composition of the extracellular solution surrounding the cells creates great osmotic pressure. Following the laws of osmosis, water will either be lost from the sperm cells if the extracellular solution is higher in ionic concentration, or drawn into the sperm cells if the extracellular solution is lower in ionic concentration. Osmotic shock would result with rapid dilutions, as the great osmotic pressure created so suddenly would not allow adequate time for the gradual movement of water into or out of the sperm cells (Palmer, Hogan and Barlow 1994).

This would explain why a significant decrease in activity resulted after the addition of diluents in dhufish trials 1 and 2, but not in trial 3. The longer, 30 second intervals between each successive addition of diluent in the third trial would have minimised the effect of osmotic shock. The snapper activities were not affected by diluent addition, so osmotic shock is not an issue. However, the black bream activities decreased significantly after dilution. Since diluent addition was fairly slow throughout the trials, it is possible that osmotic shock is not the only issue.

#### *Toxicity of cryoprotectants*

Another factor that could be contributing to reduced activities after diluent addition is related directly to the cryoprotectants. Various cryoprotectants become toxic to biological material at high concentrations (Leung 1987). DMSO is known to be one of the most toxic cryoprotectants (Leung 1987, Bromage and Roberts 1995, Stoss and Holtz 1983). However, when used at the correct concentration, it can also be one of the most successful. Likewise, glycerol has been known to be toxic to salmonid spermatozoa (Gwo *et al* 1991, Scott and Baynes 1980, Stoss 1983). Yet, studies on yellowfin bream concluded that glycerol was the most successful cryoprotectant (Thorogood and Blackshaw 1992). The use of a cryoprotectant is species specific, and so one will not be universally successful for all species.

It is therefore possible that one of the cryoprotectants used in the dhufish, black bream and snapper trials may have been slightly toxic to one or more of these species. This should be considered for the dhufish and black bream trials in particular, where the activity of sperm cells was significantly reduced after the addition of diluents. In dhufish trial 1 glycerol performed better than DMSO. In contrast, the combined data from the second and third trials indicated that

DMSO out-performed glycerol. Given this apparent conflict, it is unlikely that either diluent is more toxic to the dhufish spermatozoa. Thus, the reduction in activity after dilution of dhufish spermatozoa is more likely a result of the above-mentioned osmotic shock, than a result of toxic cryoprotectants. Either way, it becomes apparent that dhufish spermatozoa are quite sensitive to changes in their extracellular medium.

The black bream spermatozoa appear to be just as sensitive to such changes. With no significant differences between DMSO and glycerol for pre-freeze activity, it appears that neither cryoprotectant is more toxic to the sperm cells. However, it is possible that both diluents are toxic to black bream, and maybe even dhufish, spermatozoa. The DMSO diluent and the glycerol diluent both contain glycerol. Subsequently, if glycerol is toxic to the black bream sperm cells, both diluents would have detrimental effects on activity after addition. Further studies need to be conducted to determine if glycerol is toxic to black bream and dhufish spermatozoa.

The snapper spermatozoa appear to be highly resistant to change in their extracellular surroundings. The addition of diluents to the semen samples did not result in a significant decrease in activity as with the other two species. Rather, the pre-freeze activity remained fairly high, suggesting that snapper sperm cells are quite tolerant and hardy. However, for pre-freeze activity, the DMSO was significantly higher than the glycerol. This could be due to a slight toxic effect from the glycerol, yet since both diluents contain glycerol, this is not very likely. The difference could probably be attributed to sampling error.

### ***Cooling and Thawing rates***

A significant decrease in activity from pre-freeze to post-freeze occurred for all of the trials, except for snapper. The decrease in activity after thawing can be attributed to a number of factors, including the freeze and thaw rates. The most consequential factor influencing success after cryopreservation is the rate of freeze. As a solution of semen and diluent is cooled, the water molecules surrounding the sperm cells begin to freeze and the concentration of the extracellular solution subsequently increases. With a slow cooling rate, there is ample time for the movement of water, and so water is lost from the spermatozoa in an attempt to maintain osmotic equilibrium with the extracellular solution (Leung 1987). This results in the dehydration of spermatozoa, which can be fatal depending on the size of the cells and the actual cooling rate (Bromage and Roberts 1995). The slower the cooling rate, the more severe the dehydration and the less likely that the spermatozoa will survive. In contrast, with a high cooling rate the movement of water is prohibited by the shorter time, and dehydration does not occur. However, insufficient time for water to diffuse out of the spermatozoa leads to freezing within the cells, again as an attempt to equilibrate with the extracellular solution. This is known as intracellular ice (Leung 1987), and will result in rupture of the sperm cell membrane. Obviously, a balance needs to be met to ensure success in freezing spermatozoa. The correct freeze rate for fish spermatozoa is very species specific.

The rate of freeze, however, is not the only factor influencing the outcome of cryopreservation. The thawing rate is also a crucial factor. With a slow thaw rate, small ice crystals left within the sperm cells after freeze will reform into larger ice crystals as they reabsorb the volume of water lost during cooling (Leung 1987). This process is called recrystallisation, and results in the formation of damaging intracellular ice. Therefore, high thawing rates are more successful, as they allow insufficient time for the absorption of water and subsequent recrystallisation.

The first dhufish trial illustrates superbly the outcome of cryopreserving dhufish spermatozoa with a slow freeze. With a freeze rate averaging only -3 to -5 °C a minute, it is assumed that there was adequate time for the total dehydration of the sperm cells. This would explain the high frequency of dead samples after thawing, indicating that this cryopreservation procedure was simply unsuccessful. The second and third dhufish trials were more successful. As the major difference in technique between these two trials and the first one was the more rapid freeze rate, the difference can be partially attributed to the use of this freeze rate rather than a slow one.

The thaw rates used for the first dhufish trial ranged from room temperature to 50 °C. With such a range of temperatures, and still no successful post-freeze activities, it is emphasised that the slow freeze rate was solely responsible. After the completion of this first trial, it was opted to follow Leung's guidelines for thawing straws and vials (1987). In all other subsequent trials, straws were thawed at room temperature and vials at 30-40 °C. For dhufish trials 2 and 3, and the black bream trials, these temperatures appeared to result in some success.

However, the overall results from these trials were not optimal, with post-freeze activities significantly lower than the initial readings. Ideally, the post-freeze activity should be similar, or equal, to the activity of the sperm cells initially. Thus, it is indicated that the freeze and thaw rates were not optimal. Since these rates are species specific, further investigation is required to find the correct freeze and thaw rates for cryopreserving dhufish and black bream spermatozoa..

The results from the snapper trial were somewhat more successful than for the dhufish and black bream. With no significant decrease from pre-freeze to post-freeze activities, it is assumed that the cooling rate and thawing rate were more efficient on snapper spermatozoa than the other species. However, a significant difference in activity from initial to post-freeze still remains. Thus, although the freeze and thaw rates were satisfactory, they were not optimal.

The straws and vials used as vessels for the semen samples seemed to have a small impact on the success of cryopreserving dhufish and black bream spermatozoa. Vials were significantly higher in activity for dhufish trials 2 and 3 combined, and for the combined black bream trials with DMSO as the diluent. In the first dhufish trial, this pattern was also suggested, yet unequal variances can not allow this to be conclusive.

Overall, the pattern appears to suggest that vials will provide slightly more successful post-freeze activities than straws for these species. In contrast, the snapper spermatozoa were not

significantly affected by the storage vessel. The vessel used for freezing appears to be species specific, as with most of the factors influencing success after cryopreservation. For instance, 0.25mL straws used for cryopreserving salmonid spermatozoa proved more successful than pellets (Erdahl *et al* 1984). In contrast, studies on the Atlantic halibut concluded that no significant difference occurred between samples frozen in straws or as pellets (Bolla *et al* 1987).

It is therefore possible that vials are significantly more successful for cryopreserving black bream and dhufish spermatozoa, yet not snapper spermatozoa. However, the results gained from this project are not conclusive, and further studies need to be carried out.

### **Conclusion**

Cryopreservation is an extremely complex process. Several problems are associated with cryopreserving dhufish, black bream and snapper spermatozoa. Firstly, a dilution effect was prevalent for the dhufish and black bream trials. With rapid additions of diluent, osmotic shock causes harm to sperm cells and decreases activity. For the black bream spermatozoa, it also appeared that the two diluents both had a slight toxic effect. It is suggested that this was due to the presence of glycerol in both. The snapper spermatozoa did not seem to suffer from dilution effects at all.

Secondly, a consistent decrease during freeze for the dhufish and black bream indicated that the freeze and thaw rates were not optimal for these species. It was apparent, however, that a fast freeze rate is more favourable to dhufish spermatozoa than a slow one. The faster rate prevents the dehydration of sperm cells during freeze. The freeze and thaw rates used throughout the trials produced satisfactory results for the snapper spermatozoa, yet they were not optimal.

The results also suggested that vials are more effective at freezing dhufish and black bream spermatozoa than straws. However, snapper spermatozoa were not affected.

All of these factors are species specific, indicating that successfully cryopreserving dhufish semen is a difficult task. The work done in this project has merely provided a beginning for the studies that need to be conducted to discover a successful freeze method for dhufish spermatozoa. However, knowing that dilution effects and freeze/thaw rates have a significant impact on semen from this species, refining the method for cryopreservation should continue from here.

If the breeding of dhufish in captivity is to be a long-term aquaculture project, then further refinement of a cryopreservation method should seriously be considered. Continued limitation in semen availability is an impediment to the successful breeding of dhufish, and cryopreservation could overcome this problem.



**REFERENCES:**

- Abord, J., 1986. The reproductive biology of the Westralian Jewfish, *Glaucosoma hebraicum* (Pisces:Glaucosomatidae). Part 1. Gonad morphology. Biology project 301/302. Curtin University, WA.
- Ashby, D., 1996. Decompression sickness in Westralian Jewfish (*Glaucosoma hebraicum*). Faculty of Agriculture, University of Western Australia.
- Blaxter, J.H.S., 1953. Sperm storage and cross-fertilisation of spring and autumn spawning herring. Nature (London), 172: 1189-1190
- Bolla, S., Holmejord, I. and Reftsie, T., 1987. Cryogenic preservation of Atlantic halibut sperm. Aquaculture, 65: 371-374
- Bromage, N.R. and Roberts, R.J., 1995. Broodstock management and egg and larval quality. Blackwell Scientific.
- Cleary, J.J., 1998. Report to Fisheries Research and Development Corporation. Progress to 30 June 1998. Aquaculture Development Unit, Fremantle Maritime Centre, South Metropolitan College of TAFE.
- Cleary, J.J., Jenkins, G.I. and Partridge, G.J., 1999. Preliminary manual for the hatchery production of WA dhufish (*Glaucosoma hebraicum*). Aquaculture Development Unit, Fremantle Maritime Centre, South Metropolitan College of TAFE.
- Erdahl, A.W., Erdahl, D.A. and Graham, E.F., 1984. Some factors affecting the preservation of salmonid spermatozoa. Aquaculture, 43: 341-350
- Gwo, J., Strawn, K., Longnecker, M.T. and Arnold, C.R., 1991. Cryopreservation of Atlantic croaker spermatozoa. Aquaculture, 94: 355-375.
- Hesp, S.A. and Potter, I.C. 2000. Determination of the biological parameters required for managing the fishery of West Australian dhufish. FRDC Project 96/103. Murdoch University, Murdoch WA.
- Leung, K.P.L., 1987. Fish spermatology. Ultrastructure, phylogeny and cryopreservation. University of Queensland.
- McKay, R.J., 1997. FAO species catalogue. Pearl perches of the world (Family Glaucosomatidae). An annotated and illustrated catalogue of the pearl perches known to date. FAO Fisheries Synopsis. 125(17). Food and Agriculture Organisation of the United Nations, Rome, 26p.

- Palmer, P.J., Hogan, A.E. and Barlow, C.G., 1994. Chilled storage of pikey bream (*Acanthopagrus berda*) sperm and activation in different salinities. *Asian Fisheries Science*, 7: 35-40
- Scott, A.P. and Baynes, S.M., 1980. A review of the biology, handling and storage of salmonid spermatozoa. *J.Fish Biol.*, 17: 707-739
- Stoss, J., 1983. Fish gamete preservation and spermatozoa physiology. In: W.S. Hoar, D.J. Randall and E.M. Donaldson (Editors), *Fish Physiology*, Vol 9B, Academic Press, New York, NY.
- Stoss, J. and Holtz, W., 1983. Cryopreservation of rainbow trout (*Salmo gairdneri*) sperm. IV. The effect of DMSO concentration and equilibrium time on sperm survival, sucrose and KCl as extender components and the osmolality of the thawing solution. *Aquaculture*, 32: 321 - 330.
- Thorogood, J. and Blackshaw, A., 1992. Factors affecting the activation, motility and cryopreservation of the spermatozoa of the yellowfin bream, *Acanthopagrus australis* (Gunther). *Aquaculture and Fisheries Management*, 23: 337-344.

## Appendix M

© CSIRO Australia 1998

Mar. Freshwater Res., 1998, 49, 133–42

## Hormone-induced spawning and development of artificially reared larvae of the West Australian dhufish, *Glaucosoma hebraicum* (Glaucosomatidae)

Françoise N. Pironet<sup>A</sup> and Francisco J. Neira<sup>B</sup>

<sup>A</sup>Aquaculture Development Unit, Fremantle Maritime Centre, 1 Fleet Street, Fremantle, WA 6160, Australia.

Present address: Ecloserie d'Ambararata - Aquamen, BP 323, Morondava 619, Madagascar

<sup>B</sup>Marine and Freshwater Resources Institute, PO Box 114, Queenscliff, Vic. 3225, Australia. Author for correspondence. email: f.neira@msl.oz.au

**Abstract.** Hormone-induced spawning of the West Australian dhufish, *Glaucosoma hebraicum* (Glaucosomatidae) is reported, and the artificially-reared eggs and larvae are described. Hormones tested were hCG, Ovaprim and LHRH analogue, the last both as implants and in a saline solution. Late-stage fertilized eggs are spherical (960–1200 µm); possess a pigmented oil globule (210–273 µm) anteriorly on the unsegmented yolk, and hatch in about 32 hours at ~23°C. Newly hatched larvae (1.75–2.10 mm) have a prominent yolk sac which is resorbed after 3.3 days. The mouth becomes functional from Day 3, first feeding occurs from Day 3.5 and the inflated gas bladder is first observed from Day 4.3. Larvae examined (1.75–8.13 mm) have a moderately deep body, 24–25 myomeres, early-forming pelvic fins that are heavily pigmented by the postflexion stage, small to moderate head spination, no gap between anus and anal-fin origin, and a distinct pattern of pigmentation. Notochord flexion occurs between 3.42 (15 days) and 4.83 mm (25 days), and the transition to the juvenile stage starts from ~8 mm (45–46 days). Comparisons with taxa with similar larvae show that *Glaucosoma* larvae share some similarities with pempherid larvae, although the evidence is not sufficient to strengthen the view that both groups are closely related.

*Extra keywords:* eggs, spawning induction

### Introduction

The West Australian (WA) dhufish, *Glaucosoma hebraicum* Richardson, 1845 (Family Glaucosomatidae) is predominantly a benthic species endemic to Western Australia, commonly found around caves and ledges on offshore reefs between Shark Bay (25°30'S, 114°30'E) and the Recherche Archipelago (33°52'S, 121°54'E), to depths of ~200 m (Hutchins and Swainston 1986; Paxton and Hanley 1989; McKay 1997). The dhufish is a highly regarded table fish and one of the most popular recreational fish in Western Australia, attaining a maximum size of 1.22 m total length and 26 kg (Hutchins and Swainston 1986; Kailola *et al.* 1993; McKay 1997). It is caught throughout the year across most of its distributional range, with commercial catches of 100–200 t year<sup>-1</sup> between 1992–93 and 1996–97 (Kailola *et al.* 1993; Anon. 1997).

A great deal of knowledge of early life history of temperate Australian fishes has been gained from fish culture. Whereas aquaculture research on freshwater species has been aimed mainly at rearing larvae for restocking programmes in inland waterways (e.g. Rowland 1983, 1988), rearing of marine and estuarine fishes has been aimed at species suitable for commercial aquaculture (e.g. Ruwald *et al.* 1991; Battaglene and Talbot 1992, 1994). In Western Australia there has been success in rearing black bream (*Acanthopagrus butcheri*) and snapper (*Pagrus auratus*)

and, in the past two years, the WA dhufish *G. hebraicum* (Jenkins and Frankish 1997). Biological data on dhufish suggest that this species may have attributes that make it highly attractive for aquaculture, including fast initial growth and easy handling in captivity (Hesp 1997). In addition, a market survey suggested that an opportunity existed in Australia for its commercial aquaculture (I. Barnetson, unpublished).

The limited information on the reproductive biology of *G. hebraicum* indicates that this species is a multiple spawner, spawning at depths of 40–50 m between late November and April, with a peak in late January and early February. In addition, fecundity estimates range from 0.3 million to 4 million eggs, with females reaching first maturity at 25–30 mm standard length by the end of their fifth year (Cockman and McGuire 1986; Hesp 1997). Despite several ichthyoplankton surveys carried out in waters south of Shark Bay (WA) in recent years (e.g. Jonker 1993; Kendrick 1993), neither eggs nor larvae of *G. hebraicum* have been reported, and no records are available of juveniles <60 mm total length (Sudmeyer *et al.* 1990). The present paper briefly describes the hormone-induced spawning of *G. hebraicum* and provides a description of the early life-history stages of this species based on material reared in the laboratory. The methods and results presented here on the hormone-induced spawning are only preliminary, and controlled quantitative

studies are required. The descriptions of the eggs, and of the larvae from the yolk-sac through to the postflexion stage, constitute the first for fishes of the family Glaucosomatidae.

## Materials and methods

### Broodstock

*Glaucosoma hebraicum* adults (1.6–12.0 kg) were caught by hand-line between 1995 and 1997 off Lancelin (31°0'S, 115°18'E), in depths of <25 m. Upon capture, fish were placed directly into a 250-L seawater container and transported to the research centre for acclimatization. Captive dhufish were kept in several fibreglass and concrete 10–50 m<sup>3</sup> tanks at densities of 0.5 to 3.0 kg fish m<sup>-3</sup> with continuously flowing seawater, and a minimum exchange of 10% h<sup>-1</sup>. Male:female ratio ranged from 1:1 to 1–2:3–4. A net (500 µm mesh) was installed on each tank overflow to collect naturally spawned eggs.

### Hormonal treatment

Broodstock fish were anaesthetized with 300 mL m<sup>-3</sup> of 2-phenoxy-ethanol. Each fish was tagged intraperitoneally with a passive transponder 11.5 mm long × 2.0 mm diameter. For examination of maturity stage, sperm were sampled by manual stripping and oocytes by using a sterile plastic cannula. Oocytes were examined under a dissecting microscope and the diameters (µm) of the largest oocytes were measured with an eyepiece micrometer.

**Males.** A total of 17 males were treated with human chorionic gonadotrophin (hCG), and LHRH analogue (LHRH-a; des-Gly<sup>10</sup>, [D-Ala<sup>6</sup>]-luteinizing hormone-releasing hormone ethylamide) in a 95% cholesterol-base slow-release implant (LHRH-a *imp*) and in a saline solution (Table 1).

**Females.** A total of 22 females with oocytes ≥400 µm in diameter were injected intraperitoneally with various dosages of hCG, LHRH-a *imp*, LHRH-a in a saline solution, and Ovaprim containing gonadotrophin-releasing hormone (GnRH) and Domperidone (Table 1). The sterile needles used for injection were 18-gauge for liquid hormones and 2 mm diameter for implants. Fish were anaesthetized and their eggs were stripped manually at the first sign of ovulation.

### Artificial fertilization

Sperm samples were collected in sterile syringes by manually stripping anaesthetized fish. Each sample was examined under a compound microscope and sperm showing low or no motility was rejected. The selected sperm was kept at room temperature for a maximum of 1 h before it was used.

Eggs from females that had ovulated were manually stripped into plastic containers, transferred into a 1-L container of seawater (filtered to 1 µm absolute) and sterilized by ultraviolet radiation. Sperm from at least two males was added to the suspension of eggs, gently mixed and left for about

5 min, and the floating fraction then disinfected and transferred into an incubator. Fertilized eggs were rinsed with 22–24°C seawater (filtered to 1 µm absolute), sterilized by ultraviolet radiation and incubated.

### Rearing of larvae

Larvae were reared under continuously flowing seawater that was filtered to 1 µm absolute by cartridge filtration and sterilized by ultraviolet radiation. Water temperature was maintained between 22° and 24°C. Larvae were fed rotifers (*Brachionus plicatilis*) and developmental stages of brine shrimp (*Artemia salina*).

### Material examined

Naturally and hormonally induced spawned eggs of *G. hebraicum*, both unfertilized and fertilized, were measured to the nearest 10 µm under a dissecting microscope fitted with an eyepiece micrometer (Table 2). A total of 131 laboratory-reared larvae (1.75–8.13 mm body length, BL) were used (Table 3) to describe morphometrics and pigmentation. Larvae had been fixed in 5% formaldehyde and later preserved in 70% ethanol. Representatives of the larvae examined were lodged with the Australian Museum (Sydney). Two artificially reared juveniles (22.54–24.25 mm BL) were also examined (excluded from Table 3).

Terminology used to describe head spines and morphometric measurements of larvae follows Neira *et al.* (1998). All measurements were made to the nearest 0.01 millimetre under a dissecting microscope fitted with an eyepiece micrometer. Body length (BL) corresponds to notochord length (tip of snout to tip of notochord) in preflexion and flexion larvae, and to standard length (tip of snout to posterior margin of hypurals) in postflexion larvae. Measurements of body depth (BD), head length (HL) and preanal length (PAL) given throughout the text and in Table 3 are expressed as a percentage of body length. Body depth and head length (in terms of % BL) were used to describe a larva as either very elongate (BD <10%), elongate (BD 10–20%), moderate (BD 21–40%) or deep (BD 41–70%), and as having a small (HL <20%), moderate (HL 20–33%) or large head (HL >33%); preanal length was used to characterize a larva as having a moderate (PAL 30–50%), long (PAL 51–70%) or very long gut (PAL >70%). Pigment described refers solely to melanin. Illustrations were made with the aid of a camera lucida.

## Results

### Natural spawning

The smallest captive male and female dhufish in spawning condition were 47 cm total length (2.2 kg) and 43 cm total length (1.6 kg), respectively. Natural maturation in males was recorded between December and April. Most females underwent gonadal development but did not ovulate or spawn naturally.

### Induced spawning

Induced maturation was initially best achieved with implants of about 100 µg kg<sup>-1</sup> LHRH-a *imp*. Saline injections of hCG and LHRH-a did not induce spawning in males, but LHRH-a *imp* stimulated some sperm production. Sperm produced by males injected with LHRH-a *imp* was similar to that obtained in mature males that were not injected, and contained a high density of highly motile spermatozoa. The three hormones tested on females (Table 1) induced final maturation of oocytes and ovulation, particularly LHRH-a which induced egg production at all dosages. However, although treatments with either LHRH-a

Table 1. Hormone treatments in male and female *Glaucosoma hebraicum*

	Hormone	Dosage
Males	hCG	770–1130 IU kg <sup>-1</sup>
	LHRH-a <i>imp</i>	29–111 µg kg <sup>-1</sup>
	LHRH-a (saline solution)	67–80 µg kg <sup>-1</sup>
Females	hCG	870–1200 IU kg <sup>-1</sup>
	LHRH-a <i>imp</i>	5–125 µg kg <sup>-1</sup>
	LHRH-a (saline solution)	5 µg kg <sup>-1</sup>
	Ovaprim	6 µg GnRH kg <sup>-1</sup>

Table 2. Diameter ( $\mu\text{m}$ ) of eggs of *Glaucosoma hebraicum* spawned naturally and after hormone treatment  $n$ , no. of eggs measured. F, fertilized; UF, unfertilized

	Naturally spawned	hCG			LHRH-a imp	
	UF	870 IU $\text{kg}^{-1}$ UF	1200 IU $\text{kg}^{-1}$ UF	1200 IU $\text{kg}^{-1}$ F	100 $\mu\text{g kg}^{-1}$ UF	109 $\mu\text{g kg}^{-1}$ F
Range	1000–1200	1000–1120	960–1060	1000–1080	1000–1060	1000–1100
Mean $\pm$ 2 s.e.	1074 $\pm$ 21	1047 $\pm$ 24	1014 $\pm$ 7	1041 $\pm$ 15	1035 $\pm$ 10	1046 $\pm$ 5
$n$	20	14	51	14	17	76

Table 3. Body length, age and body proportions of larval stages of *Glaucosoma hebraicum* reared in the laboratory  $n$ , no. larvae; BL, body length; HL, head length; BD, body depth; PAL, preanal length. Values for HL, BD and PAL given as percentage of body length and shown as range and mean  $\pm$  2 s.e.

	Larval stage			
	Yolk sac ( $n = 36$ )	Preflexion ( $n = 47$ )	Flexion ( $n = 23$ )	Postflexion ( $n = 25$ )
BL (mm)	1.75–2.60	2.30–3.95	3.42–4.80	4.83–8.13
Age (days)	0–3	3–15	16–27	25–46
HL (% BL)	9.2–25.0 (16.3 $\pm$ 1.6)	18.8–39.1 (29.0 $\pm$ 1.5)	34.9–50.0 (40.8 $\pm$ 1.5)	35.2–59.1 (43.1 $\pm$ 1.8)
BD (% BL)	7.8–21.7 (13.0 $\pm$ 1.3)	16.5–27.3 (20.0 $\pm$ 0.7)	33.5–42.4 (37.9 $\pm$ 1.0)	36.8–50.7 (44.8 $\pm$ 1.4)
PAL (% BL)	48.9–65.4 (56.2 $\pm$ 1.4)	46.1–66.5 (54.1 $\pm$ 1.2)	59.3–68.7 (64.0 $\pm$ 0.9)	64.1–73.5 (68.3 $\pm$ 1.0)

or Ovaprim also resulted in hormonally assisted natural spawning of viable eggs, females treated with hCG did not spawn naturally and eggs had to be stripped manually. In addition, eggs released by females treated with either LHRH-a or Ovaprim were fertilized by the males in the tanks.

#### Description of eggs

Eggs are spherical and positively buoyant, have a smooth, unpigmented chorion, and range between 960 and 1200  $\mu\text{m}$  in diameter (1039  $\pm$  5  $\mu\text{m}$ , mean  $\pm$  2 s.e.;  $n = 192$ ). No significant differences were found in the diameters of naturally and hormonally induced spawned, fertilized and unfertilized eggs (ANOVA,  $P > 0.05$ ; Table 2). Late-stage fertilized eggs possess a large pigmented oil globule (240  $\pm$  6  $\mu\text{m}$  diameter, mean  $\pm$  2 s.e.;  $n = 24$ ) located anteriorly in the unsegmented yolk. Eggs hatched in  $\sim 32$  h at  $\sim 23^\circ\text{C}$ .

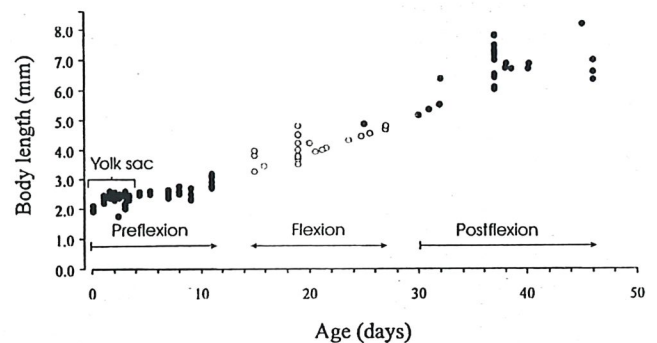

Fig. 1. Body length (mm) v. age (days) of reared larvae of *Glaucosoma hebraicum*. Open circles (o) show larvae undergoing notochord flexion.

#### Identification of larvae

Identification of the reared larvae as those of *G. hebraicum* Richardson, 1845 was confirmed by comparing the fin meristics obtained from the largest larva in our series with that provided for adults of this species in the literature (D VIII, 11; A III, 9; P<sub>1</sub>, 16; P<sub>2</sub> I, 5; McKay 1997). A developmental series from the largest to the smallest larva was assembled using body shape, head spines, gut shape, sequence of fin development, and pattern of pigmentation.

#### Description of larvae

**Age and size range of developmental stages.** Newly hatched yolk-sac larvae (0 h) measured between 1.75 and 2.10 mm (Figs 1, 2). The yolk sac was completely resorbed after 3.3 days. The largest yolk-sac larva measured 2.60 mm and the smallest larva without a yolk sac measured 2.30 mm (Table 2). The preflexion stage, i.e. after yolk-sac resorption and before the flexion stage, lasted about 15 days, with larvae ranging between 2.30 and 3.95 mm (Fig. 1). Flexion of the notochord commenced around Day 15 and was complete between Days 25 and 30. The smallest and largest larvae undergoing flexion measured 3.42 (Day 15) and 4.80 mm

(Day 27), respectively. The smallest postflexion larva measured 4.83 mm and corresponded in morphology to a 25-day-old larva (Table 3; Fig. 1).

**Morphology.** Larvae are very elongate to moderate in depth during the yolk-sac to preflexion stage (BD 7.8–27.3%), gradually becoming deep by the postflexion stage as the gut enlarges and becomes voluminous (BD 36.8–50.7%; Table 3). The snout is round and short, and the head becomes large from the flexion stage (HL 34.9–50.0%), reaching to ~60% of the body length in postflexion larvae (mean 43.1%). Both the relative depth of the body and the head length remain similar and increase at a similar rate during development. The relative distance between the snout and the anus remains long throughout development (PAL 54.1–68.3%, Table 3), as the gut does not lengthen with growth.

Newly hatched larvae possess a moderately large, unsegmented yolk sac (length across 48.8–63.8% BL) with a large, pigmented oil globule located anteriorly in the sac, and they have no formed eyes, mouth or pectoral-fin buds (Fig. 2A). The eyes are barely distinguishable and unpigmented in yolk-sac larvae but are developed, round and fully pigmented in early preflexion larvae from 2.30 mm (3 days; Fig. 2B). The mouth becomes functional in preflexion larvae from Day 3 and first feeding (rotifers) occurs after 3.5 days. Small villiform teeth develop along the premaxilla in preflexion larvae from 2.60 mm (7 days) and along the dentary from 3.12 mm (11 days; Fig. 2C). The gill membranes are free from the isthmus. A small inflated gas bladder is evident from the late preflexion stage from 2.45 mm (4.3 days). The gut in newly hatched larvae has a distinctly coiled foregut and an uncoiled, elongate hindgut; the gut becomes voluminous in late preflexion larvae, and triangular and compact in late postflexion larvae (Figs 2B–2H). A short preanal membrane is present until the late flexion stage (Figs 2B–2F), and there is no gap between the anus and the origin of anal fin. There are 24–25 myomeres (10 + 15 = 25 vertebrae; McKay 1997). Scales start to form in late postflexion larvae from about 7.00 mm (37 days) and were still developing in the largest larva examined (8.13 mm; 45 days) (Fig. 2H).

Larvae possess small to moderate head spination comprising anterior and posterior preopercular spines, opercular, subopercular, interopercular, posttemporal and supracleithral spines, a small sphenotic ridge and a smooth supraocular ridge (Figs 2D–2H). Two posterior preopercular and 3–5 anterior preopercular spines appear during the late preflexion and flexion stage, respectively. Posterior and anterior preopercular spines increase to 7–10 and 8–10 spines from 6.02 mm (37 days), respectively, and remain small during development; both sets of spines are present in the largest larva examined (Fig. 2H). A small subopercular

spine forms by 4.20 mm (19 days), and one small interopercular spine by 4.80 mm (19 days); the subopercular spine remains single while the number of interopercular spines increases to 4–5 by 6.02 mm (37 days). An opercular spine develops from 4.60 mm (19 days). The smooth supraocular ridge forms during the flexion stage (Figs 2E, 2F) and becomes prominent from 5.16 mm (30 days). The small sphenotic ridge develops from 5.16 mm (30 days) and becomes blunt from 7.00 mm (45–46 days). A low posttemporal ridge forms during the flexion stage and is present in the largest larva examined with up to four peaks (Fig. 2H). The supracleithral spine begins to form soon after notochord flexion is complete and develops 2–4 small peaks from 5.16 mm (30 days). All spines, and the supraocular and sphenotic ridges, were present in the largest larva and two juveniles examined (22.54–24.25 mm).

**Development of fins.** Pectoral-fin buds appear in early preflexion larvae from 2.30 mm (3 days), when the yolk sac is almost completely resorbed. Incipient pectoral-fin rays appear in late flexion larvae from 4.60 mm (19–20 days) and all rays (16) are formed in postflexion larvae from 6.10 mm (37 days; Figs 2E, 2F, 2H). Pelvic-fin buds, and dorsal-, caudal- and anal-fin anlagen appear simultaneously in late preflexion larvae from 3.82 mm (15 days; Fig. 2D). Incipient pelvic-fin rays are present in flexion larvae from 4.00 mm (19 days) and all elements (I, 5) are developed in early postflexion larvae from 5.16 mm (30 days). Incipient dorsal- and anal-fin rays appear in flexion larvae from 4.00 mm (19 days), and all elements are present in early postflexion larvae from 5.16 mm (30 days) except for the posterior-most spines of both the dorsal (VIII) and anal (III) fins which at that size are still soft rays (Fig. 2G). The full complement of dorsal-fin spines and rays (VIII, 11) is present in late postflexion larvae from 6.60 mm (45 days), and the third anal-fin spine is visible in the largest larva examined (8.13 mm, 45 days; Fig. 2H). Caudal-fin rays begin to form during notochord flexion, and the full complement (9+8) is evident in postflexion larvae from 5.16 mm (30 days). On the basis of the timing of development of all elements in each fin, the sequence of fin formation can be expressed as  $P_2, C \rightarrow P_1 \rightarrow D \rightarrow A$ .

**Pigmentation.** Larvae are initially moderately pigmented, becoming heavily pigmented with growth. Pigment intensity, as well as types of melanophores present (e.g. punctate and/or stellate), varied considerably among the larvae examined (Figs 2A–2H). Newly hatched yolk-sac larvae possess pigment on the anteriorly located oil globule, diffuse melanophores scattered dorsally along the body, a melanophore on the foregut and the hindgut above the anus, and one large melanophore midway ventrally on the tail (Fig. 2A). In live, newly hatched yolk-sac larvae (not

illustrated), two of the dorsal melanophores, i.e. the one above the foregut and the one midway along the tail, are prominent and spread into the dorsal finfold, whereas the large ventral tail melanophore spreads into the ventral finfold.

Head pigment is restricted to one melanophore on the lower jaw in preflexion larvae, increasing to up to five distinct melanophores along the ventral midline of the lower jaw in flexion larvae (Figs 2B–2F). Pigment on the head intensifies with growth and becomes heavy in late postflexion larvae, with melanophores densely distributed all over the head including the upper and lower jaw tips and lower jaw angle, along the premaxilla and dentary, along the isthmus and at the cleithral symphysis, and on the subocular and opercular areas (Figs 2G, 2H). The characteristic diagonal dark band across the eye was forming in the two juveniles examined (22.54–24.25 mm) and is present in juveniles >30 mm (>100 days) (Fig. 3). Internal pigment on the head is visible until the early postflexion stage and consists of a few melanophores around the upper jaw tip, the forebrain, ventrally along and on the junction of the mid and hindbrain, and along the cleithrum (Figs 2C–2G).

Dorsal body pigment in preflexion larvae consists of three prominent melanophores — on the nape, midway along the trunk and on the anterior portion of the tail — all of which remain prominent until the late preflexion stage (Figs 2B–2D); the nape melanophore becomes internal by the flexion stage. Ventral body pigment in preflexion larvae consists of a single melanophore on the gut, one at the anus, and up to four ventrally along the tail. Pigment dorsally on the trunk and tail, and ventrally on the gut and tail, intensifies with growth and expands laterally over the body including the trunk myosepta, covering all except the last 6–7 caudal myomeres in late preflexion to late flexion larvae, and the last 3 caudal myomeres in postflexion and late postflexion larvae (Figs 2E–2H). The entire caudal peduncle was pigmented in the juveniles examined. The gut becomes heavily pigmented in late postflexion larvae (Fig. 2H). Internal pigment is present over the gas bladder in preflexion larvae from 2.45 mm, and dorsally along the gut and notochord, and remains visible until the late flexion stage (Figs 2E, 2F) before becoming obscured by the external pigmentation. The characteristic six horizontal dark bands along the body, which usually disappear in older adults, were present in the juveniles examined (Fig. 3).

Pigment on the pelvic-fin buds starts to form during the late flexion stage and the fins become heavily pigmented from the early postflexion stage (Fig. 2G); both fins were also heavily pigmented in the juveniles examined. All other fins remain unpigmented during development except for pigment on dorsal-fin spines I–VII and the interconnecting fin membrane, and the bases of the second dorsal and anal fin (Fig. 2H). The pectoral-fin base becomes pigmented

during the late postflexion stage. No pigment was present on the second dorsal, caudal, anal and pectoral fins in the juveniles examined.

## Discussion

### *Hormone-induced spawning*

Preliminary results of this study showed that hormonal maturation and ovulation of WA dhufish, *Glaucosoma hebraicum*, as well as the artificial rearing of eggs through to the juvenile stage, could be successfully achieved. The minimum total lengths of sexually mature dhufish found in this study, i.e. 47 cm for males (m) and 43 cm for females (f), were greater than those described by Hesp (1997) (m, 35–40 cm; f, 25–30 cm). Whereas most male dhufish matured naturally, wild-caught females did not readily spawn in captivity but responded well to hCG, LHRH-a and Ovaprim. Both hCG and LHRH-a have been successfully used to induce oocyte maturation in several other marine finfish species, including hCG in grouper (*Epinephelus striatus*) and snapper (*Pagrus auratus*), and LHRH-a in milkfish (*Chanos chanos*) and barramundi (*Lates calcarifer*) (Lee *et al.* 1986; Garcia 1989; Battaglione and Talbot 1992; Watanabe *et al.* 1995). In addition, Ovaprim has been used to induce ovulation in several freshwater fish species (Thomas and Boyd 1989). The dosage of LHRH-a *imp* that provided best results for inducing maturation in dhufish lies within the range employed in other marine fishes (Garcia 1989; Mayes *et al.* 1993).

Although females injected with low dosages of either LHRH-a or Ovaprim ( $\leq 13 \mu\text{g kg}^{-1}$ ) spawned unaided, those treated with high dosages ovulated but did not spawn naturally, and eggs had to be stripped manually. Manual stripping of eggs resulted in spawns being wasted because of difficulty in assessing the exact ovulation time, poor fertilization rates, and high (30%) loss of female broodstock through repeated handling. A delay of even a few hours in stripping mature eggs can affect fertilization success in some temperate fishes (Shelton 1989), and finfish species that are susceptible to handling stress during the spawning period may fail to ovulate or may ultimately die as a result of the treatment (Billard *et al.* 1981). Although hormonal induction leading to unaided spawning is relatively uncommon (e.g. Kuo *et al.* 1988), it can result in single ovulations per season and poor fertilization rates in species such as snapper and milkfish (Lee and Tamaru 1987; Battaglione and Talbot 1992; Pankhurst and Carragher 1992).

### *Larval development and relationships*

This paper presents the first account of the early life-history stages of the percoid family Glaucosomatidae. As with most cases in which the description of larval stages of a fish species is based solely on artificially reared material,

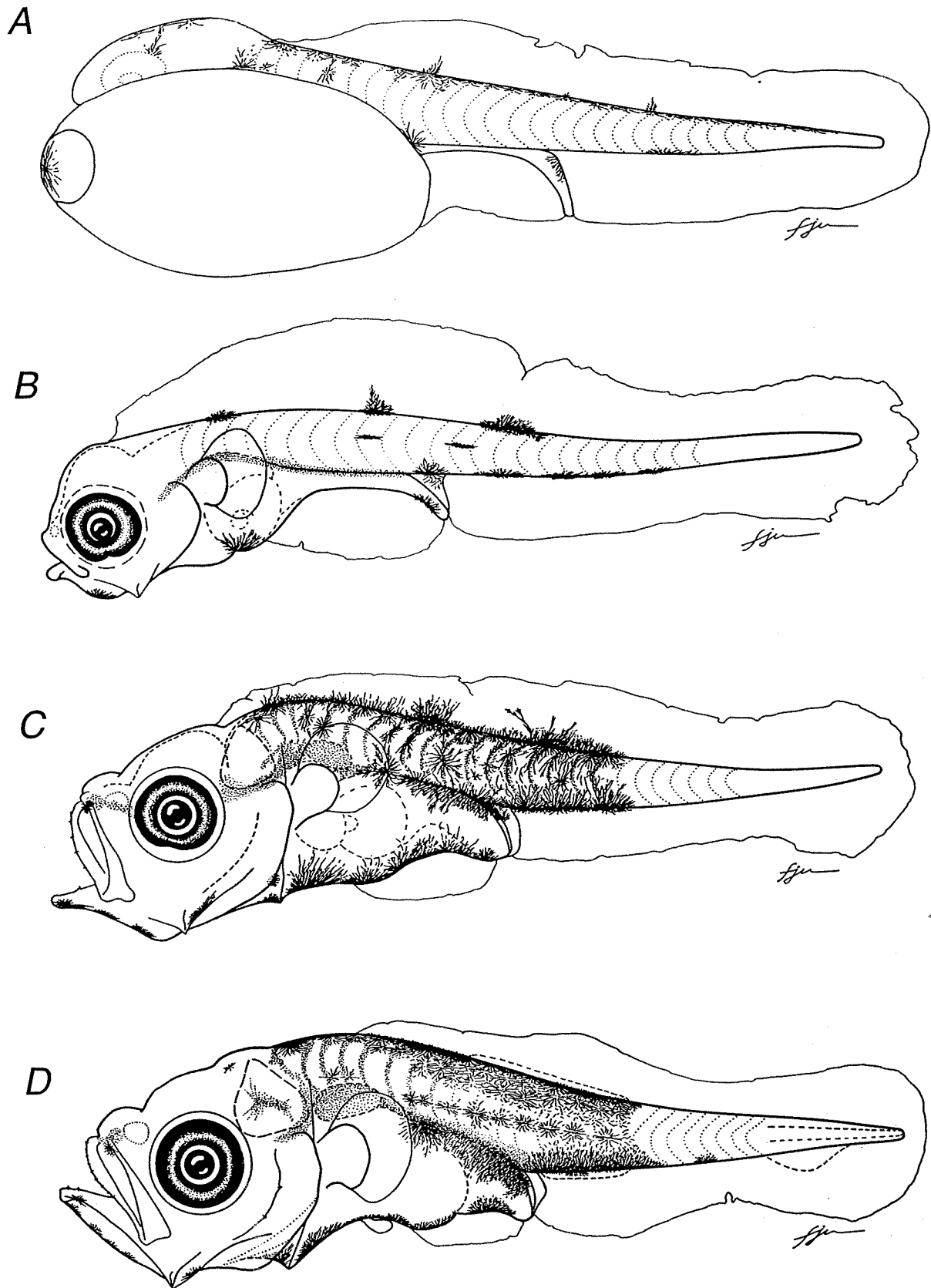

Fig. 2. Larvae of *Glaucosoma hebraicum* reared in laboratory. (A) 2.05 mm BL newly hatched, yolk sac (0 h). (B) 2.43 mm BL preflexion larva (3.3 days). (C) 3.16 mm BL preflexion larva (11 days). (D) 3.82 mm BL late preflexion larva (15 days). (E) 4.62 mm BL flexion larva (19 days). (F) 4.65 mm BL flexion larva (19 days); note expanded melanophores compared with larva illustrated in E. (G) 5.35 mm BL early postflexion larva (35 days); only last five caudal myomeres drawn. (H) 8.13 mm BL late postflexion larva (45 days); developing scales and last caudal myomeres not drawn. Illustrated by F. J. Neira.



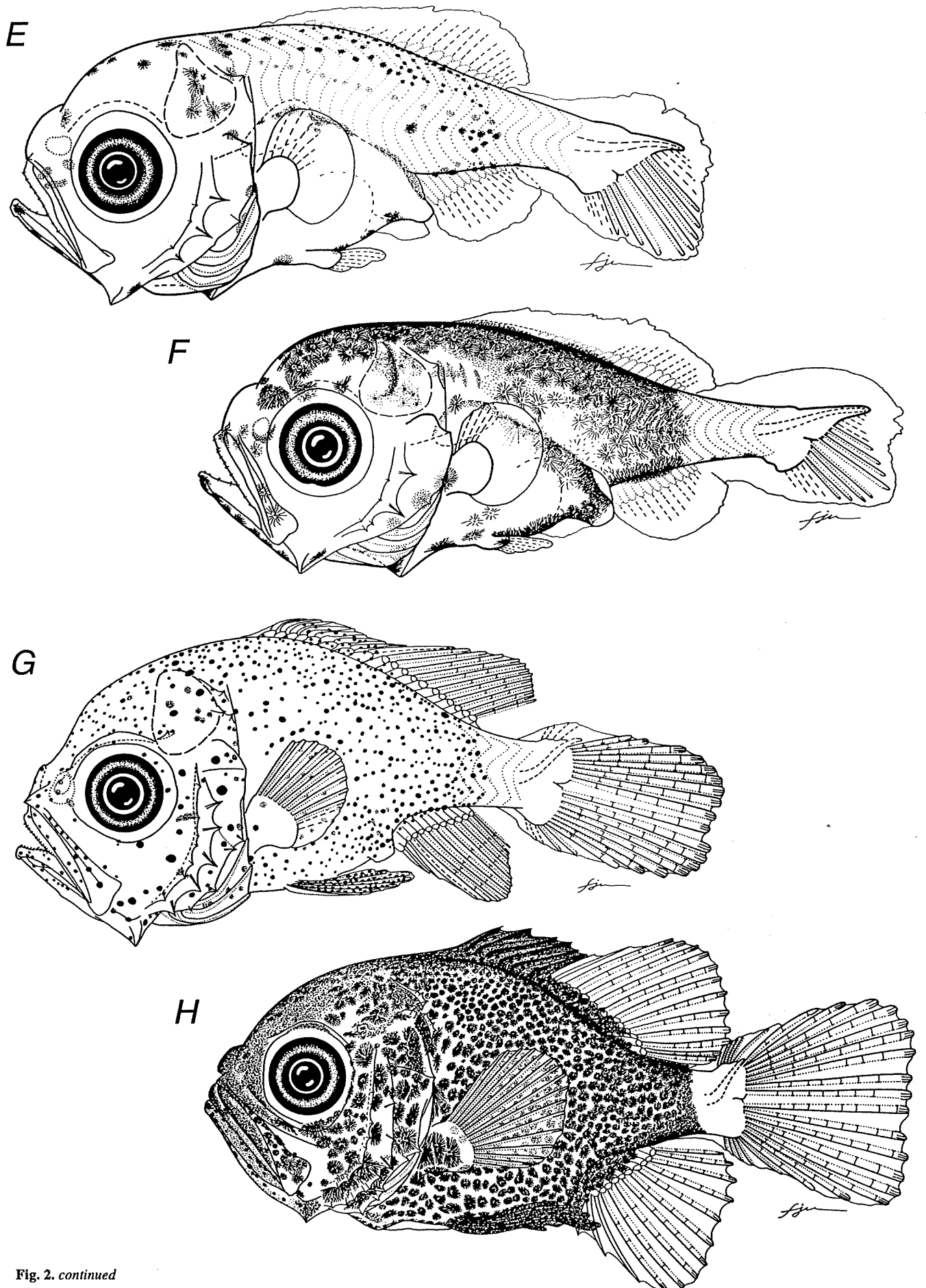

Fig. 2. continued

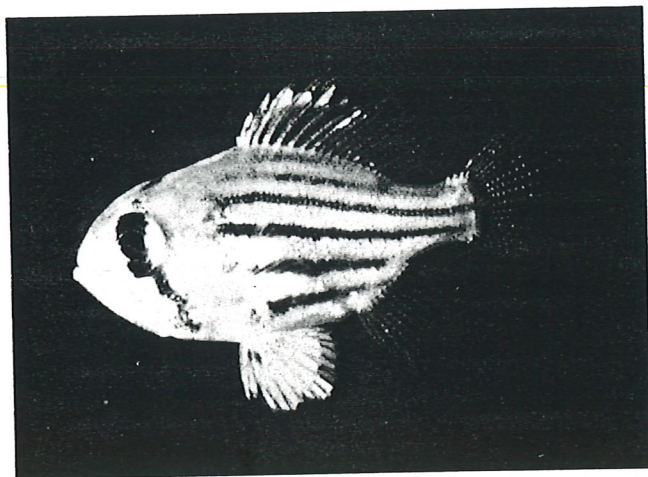

Fig. 3. 31.0 mm BL reared juvenile of *Glaucosoma hebraicum* (105 days) (photographed by J.B.Hutchins, Western Australian Museum, Perth).

it should be borne in mind that *G. hebraicum* larvae described herein may differ to some extent from field-caught larvae, given the range of conditions in rearing tanks (e.g. light intensity, temperature, larval density, food supply) and fixation time (e.g. before or after death). For example, the marked difference in pigment intensity between the two 19-day flexion *G. hebraicum* larvae drawn in our series (cf. Fig. 2E, 2F) illustrates the variability that can occur even at the same developmental stage with reared material. However, the difference between these flexion larvae (and also among several other larvae examined) seems to be associated with the expanded nature of the melanophores and not, as is often the case with reared larvae (Hunter 1984), with the presence of more pigment cells in the heavily pigmented specimen. In addition to pigment intensity, reared larvae may also differ from wild-caught larvae in those morphological characteristics that are partially controlled by environmental conditions during rearing, such as fin-ray counts (Hunter 1984). However, counts of all fin spines and rays in our reared material were identical to those provided for adult *G. hebraicum* in the literature (McKay 1997).

Reared larvae can be assigned ages (hours, days) to describe developmental stages and the duration of developmental events. During this study, both the preflexion (after yolk-sac resorption) and flexion stages lasted for several days: 3–15 and 16–27 days, respectively. In contrast, the size range of these stages was markedly narrow: 2.30–3.95 and 3.42–4.80 mm, respectively (Table 3; Fig. 1). The small variation in length compared with duration (days) of these stages implies that it could be highly misleading to assign ages to field-caught larvae based on reared material. In addition, 37–40-day-old postflexion larvae ranged between 6.02 and 7.48 mm, whereas 45–46-day-old late postflexion larvae ranged between 6.35 and 8.13 mm,

suggesting that size increments of larvae near transition to the juvenile stage decreased with increasing days after birth. A decrease in larval growth near the juvenile stage has also been described for other artificially reared marine fishes, including red sea bream (*Pagrus major*) and starry flounder (*Platichthys stellatus*) (Policansky 1982; Fukuhara 1991). As with sea bream, size rather than age of larval *G. hebraicum* is probably more suitable for estimating the onset of transition to the juvenile stage. Although the precise size range at which this transition takes place in *G. hebraicum* could not be determined from our reared series, it possibly starts at around 8 mm (45–46 days) because the largest postflexion larva examined (8.13 mm) had attained the full complement of external meristic characters, except for the scales which were still developing.

Except for the early-forming pelvic fins, the development of larval *G. hebraicum* follows a pattern similar to that found in most generalized percoids (Johnson 1984). This includes the formation of the caudal, dorsal and anal fin anlagen shortly before the start of the notochord flexion, a size at flexion between 3 and 5 mm which ends with the attainment of the full complement of caudal-fin rays, and the presence of spines on bones of both the opercular (preopercle, opercle, subopercle and interopercle) and pectoral (supracleithrum and posttemporal) series (Johnson 1984). In addition, the last dorsal-fin spine (VIII) and the last anal-fin spine (III) are initially soft rays but become spines during the postflexion stage, as with the larvae of most percoids (Leis and Trnski 1989; Neira *et al.* 1998). The precocious development of the pelvic fins constitutes the only apparent specialization of *Glaucosoma* larvae to pelagic life. This pattern of early-forming pelvic fins has also been observed in larvae of a few other percoid families, including the Lutjanidae, Monodactylidae (*Monodactylus* only), Pempheridae and Serranidae (Leis and Renniš 1983; Miskiewicz 1989), and in larvae of some members of non-percoid taxa such as beryciforms and stromateoids (Horn 1984; Neira *et al.* 1998).

*Glaucosoma*, the sole genus of the Glaucosomatidae, shares several anatomical similarities with members of the percoid family Pempheridae, including the structure of the gas bladder, the foramen on the frontal bone and the lack of direct articulation between the second epibranchial and the pharyngobranchial (Katayama 1954; Tominaga 1986; Johnson 1993). These, including the similarities between the saccular otoliths (sagittae) of *G. magnificum* and those of *Pempheris* (McKay 1997), seem to further support the close relationship *Glaucosoma*–Pempheridae that led Johnson (1993) to recommend the inclusion of the Glaucosomatidae as a subfamily of the Pempheridae. *Glaucosoma* larvae described here share several similarities with pempherid larvae, including the moderately deep body, myomere number (24–25), the early-forming pelvic fins, a similar size range at notochord flexion (3.6–4.3 mm in pempherids), the pigment pattern on the body and gut in the early stages, the

compact triangular gut, and the lack of a gap between the anus and the anal-fin origin. However, they also differ in several respects: the pelvic fins in *Glaucosoma* are initially unpigmented and form ventrally on the gut during the late preflexion stage, whereas in pempherids they are pigmented and appear first laterally on the gut in the yolk-sac stage and then migrate ventrally and anteriorly; the foregut is coiled in early preflexion *Glaucosoma* larvae, but it only starts to coil by the mid-preflexion stage in pempherid larvae; *Glaucosoma* larvae possess a more extensive head spination that includes more spines in the preopercular series, and also subopercular, interopercular and posttemporal spines, and supraocular and sphenotic ridges, all of which are absent in pempherid larvae; and *Glaucosoma* larvae lack the prominent dorsal finfold of pempherid larvae, and are generally much more heavily pigmented than pempherid larvae (Leis and Rennis 1983; Kinoshita 1988). Since there is no evidence to suggest that the similarities between *Glaucosoma* and pempherid larvae are derived, no conclusions can be drawn as to whether these support the view that both groups are closely related; this in turn illustrates the difficulty in assessing relationships among percoids by using larval characters alone (e.g. Neira *et al.* 1997).

#### Taxa with similar larvae

Larval *G. hebraicum* can be identified by the body shape, the presence of 24–25 myomeres, the early-forming abdominal pelvic fins that become heavily pigmented by the early postflexion stage, the gut that is compact and triangular-shaped from the flexion stage, the head spines, and the distinct body pigment from the late flexion stage. Field-caught *G. hebraicum* larvae are likely to be confused with those of the two other species of *Glaucosoma* found in Western Australia, namely *G. buergeri* and *G. magnificum*. Larvae of those species are undescribed but would be unlikely to co-occur with those of *G. hebraicum* since both are tropical species that are found mostly north of Shark Bay along northern Australia, including off Papua New Guinea. In addition, while dorsal and anal fin counts in *G. hebraicum* are identical to those of *G. buergeri* (D VIII,11; A III, 9), gill rakers could be used to separate late postflexion larvae of both species (4–6 + 11–13 v. 6–9 + 13–15), whereas dorsal and anal fin counts will separate postflexion larvae of both species from those of *G. magnificum* (D VIII,14; A III,12) (Allen and Swainston 1988; Paxton and Hanley 1989; McKay 1997).

*Glaucosoma* larvae can also be confused with larvae of members of the Pempheridae and with *Monodactylus* (Monodactylidae), which are found within the distributional range of *Glaucosoma* (Allen and Swainston 1988) and which possess similar body shapes and early-forming pelvic fins. However, in addition to the distinguishing features between *Glaucosoma* and pempherid larvae mentioned above, larvae of both groups can be further separated by the

higher number of anal-fin rays in pempherids (17–45 v. 9–12), whereas *Monodactylus* larvae possess a distinct wide band of heavy pigment between the snout and the anus, and a higher number of dorsal and anal-fin rays (27–32) (Leis and Rennis 1983; Kinoshita 1988; Miskiewicz 1989). Larvae of *Glaucosoma* could also be confused with larvae of non-percoids that have early-forming pelvic fins, including members of the Berycidae and Trachichthyidae (Beryciformes), and some stromateoids. However, berycids are lightly pigmented and have I, 7–13 pelvic-fin elements (Mundy 1990; Miskiewicz *et al.* 1998), trachichthyids possess 26–30 myomeres and have I, 6 pelvic-fin elements (Jordan and Bruce 1993), and stromateoids usually have 30 or more myomeres (Horn 1984).

#### Acknowledgments

We are very grateful to Franz and Mary van der Poll for helping to collect the broodstock fish and maintain a 100% survival after capture. We are also grateful to Greg I. Jenkins and to all the staff at the Fremantle Maritime Centre for their continuous assistance and support during this project. Thanks also to Roche Products Pty Ltd for the carophyll pink for the vitamin mix. We also thank Jeff M. Leis (Australian Museum, Sydney) and Tony G. Miskiewicz (AWT EnSight, Sydney), for reviewing the manuscript. Many thanks also to Sharon E. Tait and Miriana I. Sporic (Marine and Freshwater Resources Institute, Queenscliff) for laboratory work and statistical advice, respectively. Barry Hutchins (Western Australian Museum, Perth) photographed the juvenile shown in Figure 3. Editorial comments and suggestions of two anonymous referees greatly improved the paper and are also appreciated. This research was funded by the Fremantle Maritime Centre (WA), and partly funded by the Fisheries Research and Development Corporation (Projects Nos. 95/095 and 96/308).

#### References

- Allen, G. R., and Swainston, R. (1988). 'The Marine Fishes of North-Western Australia: a Field Guide for Anglers and Divers.' (Western Australian Museum, Perth.) 201 pp.
- Anon. (1997). Australian Fisheries Statistics. (Australian Bureau of Agricultural and Resource Economics: Canberra.)
- Battaglene, S. C., and Talbot, R. B. (1992). Induced spawning and larval rearing of snapper, *Pagrus auratus* (Pisces : Sparidae), from Australian waters. *New Zealand Journal of Marine and Freshwater Research* 26, 179–83.
- Battaglene, S. C., and Talbot, R. B. (1994). Hormone induction and larval rearing of mullet, *Argyrosomus hololepidotus* (Pisces : Sciaenidae). *Aquaculture* 126, 73–81.
- Billard, R., Bry, C., and Gillet, C. (1981). Stress, environment and reproduction in teleost fish. In 'Stress and Fish'. (Ed. A. D. Pickering.) pp.185–208. (Academic Press: London.)
- Cockman, B. W., and McGuire, B. (1986). Age, growth and spawning of the Westralian dhufish *Glaucosoma hebraicum* Richardson (Pisces : Glaucosomidae). Western Fisheries Research Committee – Annual Reports and Proposals, pp. 205–7. (Fisheries Department of Western Australia: Perth.)

- Fukuhara, O. (1991). Size and age at transformation in red sea bream, *Pagrus major*, reared in the laboratory. *Aquaculture* 95, 117–24.
- Garcia, L. M. (1989). Dose-dependent spawning response of mature female sea bass, *Lates calcarifer* (Bloch), to pelleted luteinizing hormone-releasing hormone analogue (LHRHa). *Aquaculture* 77, 85–96.
- Hesp, S. A. (1997). The biology of the dhufish, *Glaucosoma hebraicum*, in offshore waters on the lower west coast of Australia. BSc (Hons) Thesis, Murdoch University, Perth. 60 pp.
- Horn, M. H. (1984). Stromateoidei: development and relationships. In 'Ontogeny and Systematics of Fishes'. (Eds H. G. Moser, W. J. Richards, D. M. Cohen, M. P. Fahay, A. W. Kendall Jr and S. L. Richardson.) pp. 620–8. American Society of Ichthyologists and Herpetologists Special Publication No. 1.
- Hunter, J. R. (1984). Synopsis of culture methods for marine fish larvae. In 'Ontogeny and Systematics of Fishes'. (Eds H. G. Moser, W. J. Richards, D. M. Cohen, M. P. Fahay, A. W. Kendall Jr and S. L. Richardson.) pp. 24–7. American Society of Ichthyologists and Herpetologists Special Publication No. 1.
- Hutchins B., and Swainston, R. (1986). 'Sea Fishes of Southern Australia: Complete Field Guide for Anglers and Divers.' (Swainston Publishing: Perth, Australia.) 180 pp.
- Jenkins, G. I., and Frankish, K. (1997). The Fremantle Maritime Centre – active in supporting industry development. *Aquaculture Council of Western Australia News* 18, 24–8.
- Johnson, G. D. (1984). Percoidae: development and relationships. In 'Ontogeny and Systematics of Fishes'. (Eds H. G. Moser, W. J. Richards, D. M. Cohen, M. P. Fahay, A. W. Kendall Jr and S. L. Richardson.) pp. 24–7. American Society of Ichthyologists and Herpetologists Special Publication No. 1.
- Johnson, G. D. (1993). Percomorph phylogeny: progress and problems. *Bulletin of Marine Science* 52, 3–28.
- Jonker, L. J. (1993). Comparisons of the larval fish assemblages in healthy and degraded seagrass meadows in Cockburn Sound, Western Australia. BSc (Hons) Thesis, Murdoch University, Perth. 47 pp.
- Jordan, A. R., and Bruce, B. D. (1993). Larval development of three roughy species complexes (Pisces : Trachichthyidae), from southern Australian waters, with comments on the occurrence of *Hoplostethus atlanticus*. *Fishery Bulletin (US)* 91(1), 76–86.
- Kailola, P. J., Williams, M. J., Stewart, P. C., Reichelt, R. E., McNee, A., and Grieve, C. (1993). 'Australian Fisheries Resources.' (Bureau of Resource Sciences: Canberra.) 422 pp.
- Katayama, M. (1954). Systematic position of the genus *Glaucosoma*. *Bulletin of the Faculty of Education of Yamaguchi University* 4(1), 23–9.
- Kendrick, A. J. (1993). Assemblages of larval fishes in coastal waters of south-western Australia. BSc (Hons) Thesis, Murdoch University, Perth. 88 pp.
- Kinoshita, I. (1988). Pempheridae. In ['Atlas of the Early Stage Fishes in Japan']. (Ed. M. Okiyama.) pp. 507–9. (Tokai University Press: Tokyo.) (In Japanese.)
- Kuo, C-M., Ting, Y-Y., and Yeh, S-L. (1988). Induced sex reversal and spawning of blue-spotted grouper, *Epinephelus fario*. *Aquaculture* 74, 113–26.
- Lee, C-S., and Tamaru C. S. (1987). Application of LHRH-a cholesterol pellets to maturation of finfish: milkfish. *NOAA Technical Report* 85, 57–64.
- Lee, C-S., Tamaru, C. S., Banno, J. E., and Kelley, C. D. (1986). Influence of chronic administration of LHRH-analogue and/or 17 $\alpha$ -methyltestosterone on maturation in milkfish. *Aquaculture* 59, 147–59.
- Leis, J. M., and Rennis, D. S. (1983). 'The Larvae of Indo-Pacific Coral Reef Fishes.' (New South Wales University Press: Sydney. University of Hawaii Press: Honolulu.) 269 pp.
- Leis, J. M., and Trnski, T. (1989). 'The Larvae of Indo-Pacific Shorefishes.' (New South Wales University Press: Sydney.) 371 pp.
- Mayes, K. B., Rosenblum, P. M., and Brandt, T. M. (1993). Raceway spawning of Florida largemouth bass: effects of acclimation time and hormone treatment on spawning success. *The Progressive Fish Culturist* 55, 1–8.
- McKay, R. J. (1997). Pearl perches of the world (Family Glaucosomatidae). *FAO Species Catalogue Vol. 17. FAO Fisheries Synopsis* 125/17. 24 pp.
- Miskiewicz, A. G. (1989). Monodactylidae: Diamonfishes, moonies, fingerfishes. In 'The Larvae of Indo-Pacific Shorefishes'. (Eds J. M. Leis and T. Trnski.) pp. 196–9. (New South Wales University Press: Sydney.)
- Miskiewicz, A. G., Bruce, B. D., and Trnski, T. (1998). Berycidae: redfishes, nannygais, alfonsinos. In 'Larvae of Temperate Australian Fishes. Laboratory Guide for Larval Fish Identification'. (Eds F. J. Neira, A. G. Miskiewicz and T. Trnski.) pp. 95–6. (University of Western Australia Press: Perth.)
- Mundy, B. C. (1990). Development of larvae and juveniles of the alfonsinos, *Beryx splendens* and *B. decadactylus* (Berycidae, Beryciformes). *Bulletin of Marine Science* 46, 257–73.
- Neira, F. J., Miskiewicz, A. G., and Bruce, B. D. (1997). Larvae of five fish families with pattern 10 of the *ramus lateralis accessorius* nerve (Arripidae, Girellidae, Kyphosidae, Microcanthidae and Scorpididae): relevance to relationships. *Bulletin of Marine Science* 60(1), 117–38.
- Neira, F. J., Miskiewicz, A. G., and Trnski, T. (1998). 'Larvae of Temperate Australian Fishes. Laboratory Guide for Larval Fish Identification.' University of Western Australia Press, Perth. 475 pp. (In press.)
- Pankhurst, N. W., and Carragher, J. F. (1992). Oocyte maturation and changes in plasma steroid levels in snapper *Pagrus (=Chrysophrys) auratus* (Sparidae) following treatment with human chorionic gonadotropin. *Aquaculture* 101, 337–47.
- Paxton, J. R., and Hanley, J. E. (1989). Glaucosomatidae. In 'Zoological Catalogue of Australia, Vol. 7, Pisces: Petromyzontidae to Carangidae'. (Eds J. R. Paxton, D. F. Hoese, G. R. Allen and J. E. Hanley.) pp. 529–30. (Australian Government Publishing Service: Canberra.)
- Policansky, D. (1982). Influence of age, size and temperature on metamorphosis in the starry flounder, *Platichthys stellatus*. *Canadian Journal of Fisheries and Aquatic Science* 39, 514–17.
- Rowland, S. J. (1983). The hormone-induced ovulation and spawning of the Australian freshwater fish golden perch, *Macquaria ambigua* (Richardson) (Percichthyidae). *Aquaculture* 35, 221–38.
- Rowland, S. J. (1988). Hormone-induced ovulation and spawning of the Australian freshwater fish Murray cod, *Maccullochella peelii* (Mitchell) (Percichthyidae). *Aquaculture* 70, 371–89.
- Ruwald, F. P., Searle, L. D., and Oates, L. A. (1991). A preliminary investigation into the spawning and larval rearing of striped trumpeter, *Latris lineata*. Department of Primary Industry, Tasmanian Division of Sea Fisheries Technical Report No. 44. 17 pp.
- Shelton, W. L. (1989). Management of finfish reproduction for aquaculture. *Aquatic Sciences* 1(3), 497–535.
- Sudmeyer, J. E., Hancock, D. A., and Lenanton, R. C. J. (1990). Biological synopsis of Westralian jewfish (*Glaucosoma hebraicum*, Richardson, 1845) (Pisces : Glaucosomatidae). Western Australian Department of Fisheries, Fisheries Research Report No. 96. 20 pp.
- Thomas, P., and Boyd, N. W. (1989). Dietary administration of an LHRH analogue induces spawning of spotted seatrout (*Cynoscion nebulosus*). *Aquaculture* 80, 363–70.
- Tominaga, Y. (1986). The relationships of the families Glaucosomatidae and Pempheridae. In 'Indo-Pacific Fish Biology, Proceedings of the Second International Conference on Indo-Pacific Fishes'. pp. 595–9. (Eds T. Uyeno, R. Arai, T. Taniuchi and K. Matsuura.) (Ichthyological Society of Japan: Tokyo.)
- Watanabe, W. O., Ellis, S. C., Ellis, E. P., Head, W. D., Kelley, C. D., Moriwake, A., Lee, C-S., and Bienfang, P. K. (1995). Progress in controlled breeding of Nassau grouper (*Epinephelus striatus*) broodstock by hormone induction. *Aquaculture* 138, 205–19.

## ***Appendix N - WA Dhufish Larval Rearing - 1999/2000 End of Year Report.***

Gavin Partridge, Aquaculture Development Unit, Challenger TAFE, 1 Fleet St Fremantle, WA.

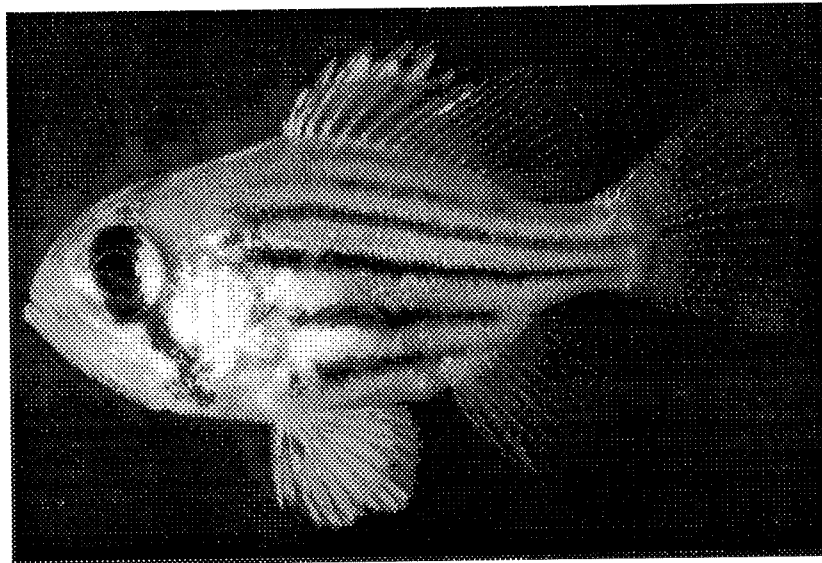

### Summary:

Significant gains in dhufish larval rearing were made in the 1998/99 season. Larvae were reared for the first time in the FMC static greenwater system, with promising results. In addition, larvae were reared for the first time in a small-scale experimental system. In this particular trial (DF99-00), larvae were fed on nauplii of cultured calanoid copepods, which resulted in high growth rates and survival rates in excess of 40%. This years larval rearing effort focussed on incorporating a self sustaining population of calanoid copepod broodstock into the FMC static greenwater system in an effort to overcome the necessity of supplying high numbers of copepod nauplii to large scale larvae culture tanks. In addition, a number of trials were planned using the small-scale experimental system, to answer important questions relating to dhufish larval culture. These trials included:

- 1) Hatch and early survival in bore water and ocean water.
- 2) Determination of the optimal time for transferring larvae from the incubation tank to the rearing tank
- 3) Hatch rate and early survival at different temperatures.
- 4) Fertilization, embryonic development, hatch and early larval survival of eggs fertilised with cryopreserved sperm.
- 5) Feeding acuity at different light intensities.
- 6) Survival of hatchlings at different light intensities.

- 7) Effect of *Artemia* enrichment on growth, survival and health.
- 8) Growth of larvae under different light intensities.
- 9) Improvements in weaning diets, timing and methods.

Unfortunately limited numbers of eggs were obtained this season which meant that only trials 1) and 4) could be carried out in addition to the copepod work. A total of 7 batches of larvae were cultured in the current season. Four of these were conducted in the blue barrel system and the remainder in 5 tonne tanks on the larval deck. Survival ranged from 0% to 10% and a total of approximately 700 weaned juveniles were produced. Samples of larvae were taken throughout the various batches and preserved in formalin, to determine the condition of the livers at various ages, and to determine if the different rearing methods influenced liver condition.

The few trials that were conducted in the small-scale experimental system experienced a high degree of variation within treatments, making detection of significant differences between treatments difficult. Due to these problems and the limited egg supply it was decided not to expend further larvae on experiments utilising this system before the reasons behind the variations were determined. One possibility for the variability could be small differences in aeration rate/circulation between tanks. To overcome these potential problems, it is planned to obtain high quality brass air-line valves to gain greater control over aeration rates. In addition, it is proposed to install a separate small blower in the larval area to ensure delivery of a constant and equal air-pressure to all tanks. The blue barrels themselves may have caused slight differences in air/water dynamics as they are all slightly different in relation to the position of the overflow and water circulation in flat-bottomed tanks may not be optimal. As was observed in DF00-01, maintaining close ranges in water temperature proved difficult in small volumes with low flow rates, particularly when ambient air temperatures differ greatly to that required in the larval tanks. The only effective method of overcoming this problem would be to house the small larval rearing containers in an air-conditioned room in addition to the use of heater/chillers. It is currently planned to replace the blue barrel system with an array of custom designed, conical bottomed larval tanks. This system will be commissioned before the next dhufish larval season and will be tested with other species including pink snapper and King George whiting. With identical fiberglass tanks with the same aeration rate and circulation patterns, and identical water quality parameters with minimal variations, intra-replicate variations should be minimised. A moderate degree of variation between replicates can be expected in any larval rearing experiment, even if the conditions appear to be identical. This highlights the need for as many replicates as possible. At least four replicates of each treatment should be applied to ensure a reasonable chance of detecting significant differences between treatments.

Attempts to reproduce the results of the successful copepod blue barrel system and the integration of copepod broodstock into the FMC system yielded poor results. The lack of performance can be attributed to the limited availability of copepod nauplii and the poor performance of both copepod broodstock and nauplii stocked into the greenwater system. The current bottleneck for reliable production of copepods is the provision of high quality algae on consistent basis. Cultures of T-Iso at the FMC are commonly contaminated by a heterotrophic haptophyte, which is difficult to avoid in large-scale non-axenic cultures. Feeding copepods on contaminated microalgae causes cultures to rapidly crash. If copepods are to be produced on a regular basis a clean source of food must be readily available. Alternative food sources are currently being investigated. These include other species of microalgae, such as *Rhodomonas baltica*. Preliminary work with this species suggests it to be a good food source which is less prone to contamination than T-Iso, however it is difficult to culture and copepods still appear to require some supplementation with T-Iso. A heterotrophic dinoflagellate, *Heterocapsa niei* is also currently under investigation. Due to its hard cell wall, this species is less prone to contamination by heterotrophic haptophytes and it appears to have excellent nutritional value for calanoid copepods. It has, however, yet to be cultured on a large scale and requires soil extract as a nutrient medium, which is very time consuming to prepare. Frozen microalgae, guaranteed free of contaminants, is also being investigated, however due to its high cost it is envisaged that this will

be useful only as a backup in times of live microalgae shortage. The most plausible solution at this point is to culture T-Iso in a more axenic environment. The existing copepod algae room could readily be converted to a bag culture room with minimal cost. The room would need to be air-conditioned and insulated to ensure a constant temperature. The banks of fluorescent lights currently in the small stock culture room could be relocated, or the metal halide lights currently in the copepod algae room could be utilised. FWA have recently purchased a bag sealer and a roll of plastic for economical manufacture of hanging bags which can be used in this room. In addition to T-Iso, alternative species such as *R. baltica* and *H. niei* could also be cultured in these bags and easily pumped to the adjacent copepod room or onto the larvae deck.

As previously stated, both copepod nauplii and broodstock did not do as well as expected when stocked into the static greenwater system. In this system, the green algae *Nannochloropsis oculata* is used as a background algae, as a food source for rotifers and to maintain water quality. Although it has been shown previously that *N. oculata* is a poor single diet for calanoid copepods, success has been achieved on a mixed diet of *N. oculata* and T-Iso. Evidence was obtained in the current season to suggest that the density of *N. oculata* and the ratio between *N. oculata* and high HUFA species, such as T-Iso, effect the performance of copepods in the greenwater system. Further work has been planned to determine the optimum density and ratios of algal species to maximise copepod production and to determine whether different life stages of calanoid copepods have different abilities to selectively graze certain species of algae from a mixed diet. Details of these experiments can be found in the enclosed project proposals. The green flagellate *Dunaliella tertiolecta* was trialed as an alternate background species to *N. oculata*, as it is known to be a superior food source for copepods. Unfortunately this species was not suitable for the static greenwater system as it dropped out of suspension.

Optimising the timing of broodstock inoculation would greatly assist in improving the production of nauplii. In all trials involving copepods, tanks were inoculated only a few days prior to the stocking of larvae. Using this method there is a lag of several days before the broodstock start producing nauplii, therefore the nauplius density is not maximised during the critical, early stages of the larvae's development. Under the current framework, it is difficult to manage the cultures any differently, as it is always unknown when larvae will become available. One potential method of overcoming this problem would be to use the tanks on larval deck as copepod culture tanks. The tanks would operate on a continuous rotation, so when larvae become available there would always be a tank in which nauplius production is at its maximum level. As copepods are currently being cultured in the same style of tank, little modification would be required on the larvae deck and it would be a very simple matter of changing the tank from a copepod culture tank to a larvae tank once larvae were stocked into it. It is proposed to trial this method during the 'off-season' when demand on these tanks is lowest. It is envisaged that two tanks would be required to ensure at least one is at peak nauplius production, with a further two required if replicated trials are to be conducted comparing copepod production with and without Aquamats, as detailed under DF00-06.

Last year it was shown that dhufish larvae could be successfully weaned onto a modified commercial pellet. Due to nutrition related health problems encountered in last years cohort of juveniles, it was decided not to wean the current batches of larvae onto this ration but directly onto flesh. This would ensure that the health and condition of the juveniles was high before commencing nutrition trials to determine the fishes nutritional requirements. Some difficulties were experienced in weaning some of the current batches of larvae, in particular those batches which were weaned late and given live ongrown Artemia. Once the larvae were feeding on live ongrown Artemia it proved difficult to encourage them to eat chopped flesh or dead Artemia. The easiest batch to wean was the last batch, DF00-07, which were weaned early and directly onto frozen Artemia.

A comparison of the growth rates of the current batches of larvae with DF99-00 and DF99-01 (static greenwater system) is given in Figure 1. The mean water temperature experienced during

each batch is given in parentheses after each batch number. In some trials the growth rates appear not to be correlated with temperature or copepod density. For example, in DF00-01 high numbers of copepods were present in the rearing tank in the latter stages of the trial, whereas in DF00-04 copepod ingestion and copepod density were low but the growth rate was much greater than experienced in DF00-01. In addition the water temperature in DF00-04 was lower than DF00-01. Observation of the mean temperature data could indicate that greater growth rates are obtained at lower temperatures, highlighting the need to quantify the growth rates and survival at different temperatures.



### Summary of Larval Batches

**DF00-01**                      **Comparison of bore and ocean water for hatching and rearing dhufish larvae.**

**Principal Investigator:** Gavin

**Broodstock History:** Female A404 (D1), Male D5 and UWW. Total eggs 60,000. Viability 100%, Fertilisation 82%. All eggs for the trial were from a single stripping.

**Incubation Notes:** 2,000 eggs stocked into each of 6 small (2.5L) cones. Remainder of the eggs were stocked into a large cone but did not hatch due to the method of stocking used (bottom harvested from the egg counting cone onto a screen). Three of the small cones were incubated in bore water and three in ocean water. Each cone was stocked into a separate blue barrel. On Day 2 the number of live larvae in each cone was determined. The number of larvae and percentage surviving to Day 2 are shown below:

Ocean 1: 400 (20%)  
 Ocean 2: 508 (25%)  
 Ocean 3: 510 (25%)  
 Bore 1 : 25 (1%)  
 Bore 2 : 458 (23%)  
 Bore 3 : 240 (12%)

**Stocking:** Larvae hatched in bore water were reared in bore water and larvae hatched in ocean water were reared in ocean water. Larvae were stocked into 4 blue barrels, two replicates per treatment. Because there were uneven numbers in each hatching cone, larvae had to be evenly distributed between the blue barrels. Numbers stocked into each barrel were:

Ocean 1: 708.  
 Ocean 2: 710.  
 Bore 1 : 320.  
 Bore 2 : 378.

**Rearing Methods:** The aim was to follow, as closely as possible, the blue barrel method used by Mic Payne in the previous year (DF99-00). Bore and ocean water were pumped from C1 and C2, respectively. Heater/chillers on both of these tanks were set at 22°C. Algae (*N. oculata*) was pumped periodically (~8min/4hrs) from a 1 tonne tank in the larval area to maintain a cell density of  $\sim 1 \times 10^6$  cells/mL. ~3 L of T-Iso was added manually to each tank in a single addition each morning. Tanks were illuminated with fluorescent light for 12 hours per day and were covered with green shade cloth giving a surface light intensity of 75 lux. In accordance with Mics previous run, flow rates were set at: 150% to Day 14; 200% to Day 20, 300% to 25, 400% to Day 28, 500% from Day 29. Tanks were fitted with 53  $\mu$ m screens to retain copepod nauplii.

<b>Water Quality:</b>	Temp:	O1:	21.0°C – 24.6°C.
	pH:	O1:	7.93 – 8.40.
	Temp	O2:	20.9°C – 24.8°C.
	pH	O2:	8.01 – 8.46.
		B1:	21.4°C – 24.1°C.
		B1:	7.67 – 8.15.
		B2:	21.2°C – 23.9°C.
		B2:	7.63 – 8.17.

Min. DO	O1:	64% (Day 14).
	O2:	76% (Day 18)
	B1:	73% (Day 16)
	B2:	72% (Day 12)

- Live food regime:**
- Rotifers stocked at 5/mL. Rotifers peaked at:
    - O1: 64/mL (Day 11)
    - O2: 56/mL (Day 19)
    - B1: 56/mL (Day 11)
    - B2: 52/mL (Day 11).

Screens were changed to 250µm overnight on Day 11 to reduce the rotifer density. On Day 27 screens were changed permanently to 250 µm.

- Each tank was inoculated with 55,000 copepod nauplii. Further additions were made on Days 4, 5, 6 & 8. Each further addition was of 18,000 nauplii, except for Day 6 when 36,000 nauplii were added. No copepod nauplii were seen in the live food counts until Day 15. It was at this stage that large numbers of broodstock copepods could be seen on the walls of all tanks and from this point good numbers of nauplii were seen in the live food counts until ~Day 30. Copepod nauplii density peaked in the different tanks at:

O1:	9.3/mL (Day 24)
O2:	5.0/mL (Day 28)
B1:	5.7/mL (Day 26)
B2:	10.7/mL (Day 23& 26).

- Enriched Artemia nauplii were introduced from Day 24. All Artemia were enriched on Superselco. Ongrown Artemia and newly hatched snapper larvae were offered from Day 34.
- Gut contents were quantified two days after the introduction of Artemia (Day 26). At this stage most larvae had started feeding on Artemia, not many eating rotifers, many eating copepodites. By Day 29 none of the larvae were observed to be consuming rotifers.

**Growth:**

	Day 4	Day 6	Day 8	Day 11	Day 14	Day 17	Day 20	Day 23	Day 26	Day 29
O1	2.8	3.1	3.2	3.7	4.0	4.4	5.0	5.8	7.9	9.0
O2	2.8	3.1	3.3	3.9	4.1	4.9	5.3	6.1	8.1	9.2
Mean O	2.8	3.1	3.2	3.8	4.1	4.6	5.2	5.9	8.0	9.1
B1	2.9	3.1	3.4	3.6	3.8	4.8	5.0	5.8	7.6	9.0
B2	2.8	3.0	3.4	3.6	3.9	4.5	4.8	5.2	7.2	8.7
Mean B	2.8	3.1	3.4	3.6	3.8	4.6	4.9	5.5	7.4	8.9

The growth rate of this batch of fish was low in comparison to the other batches reared this season (Figure 1). Due to the comparatively warm temperature and abundance of copepods in the latter stages of the trial, it was anticipated that the growth rate of these larvae would have been greater than other batches such as DF00-04, where copepod density was low. It may also have been expected that the growth rate of the current batch of larvae should have been greater than DF99-01, where larvae were reared in static greenwater, with no copepods, however, the slightly higher mean temperature in the latter trial may account for this difference.

**Transfers:** All fish combined on Day 37 into a single blue barrel. Those fish in bore water were slowly acclimated to ocean water during the two days prior to transfer and handled the acclimation with no visible signs of stress. All fish transferred to 300 L tank on Day 43 (total count: 122). Fish handled both transfers well and there were no post-transfer mortalities.

**Weaning:** Fish completely weaned from ongrown Artemia onto flesh by Day 68. No problems encountered during the wean, no major mortalities and fish took to flesh fairly easily. No ongrown Artemia (live or frozen) were used. See weaning schedule for details.

**Survival:** Day 2 to Day 37:

O1: 33 survivors from 708 larvae stocked	=	5%
O2: 62 from 710	=	9%
B1: 33 from 320	=	10%
B2: 5 from 378	=	1.3%.

**Comments/Problems/Suggestions for improvements:**

Due to the high level of variation between the bore water replicates, no significant differences in hatch rate could be determined, however, the ocean water hatch rates were all higher than those obtained in the bore water. It is believed that the high level of variability in these small cones is due to differences in aeration rate, with high levels being deleterious to the newly hatched larvae. Measures to overcome this problem are currently being investigated, such as brass air-line valves (which give greater control) and a separate blower in the larval area to ensure a constant air pressure.

There was no significant difference in survival of the larvae between the bore and ocean water treatments to Day 37. Growth in the ocean water was slightly higher than in bore water, but not significantly. A lack of consistency between replicates and the low number of replicates appeared to be the primary reasons why significant differences could not be detected in survival. The lack of replication and differences in initial stocking densities were acknowledged as problematic

before the commencement of the trial, however, it was hoped that a rough idea could be obtained as to whether ocean water was advantageous over the bore, even if scientifically significant results could not be obtained. The only firm conclusion that can be drawn from the current trial in respect to the different types of water is that larval culture is possible in 'green' bore water and growth and survival can be as high as that obtained in 'green' ocean water. The addition of microalgae to the culture water and the slow flow rate may have ensured the CO<sub>2</sub> concentration was maintained at a safe level. Although a lower pH was observed in the bore water tanks, this does not necessarily imply a high CO<sub>2</sub> content, especially in a low flow system. In future work direct measurement of free CO<sub>2</sub> will be possible, as we have since developed a simple and reliable titration for determining free CO<sub>2</sub> levels. At this point we are still unable to say with certainty whether or not ocean water is advantageous over bore water for incubation and rearing of dhufish larvae.

Of critical importance for the success of future small-scale larval work is identifying the factors causing large differences in survival between replicates. Suggestions in this area include differences in aeration rate and circulation and those potential remedies outlined in the hatching section above will also be trialled in the larvae tanks (ie standardizing aeration rates). Despite the use of the heater/chillers, problems were also encountered in maintaining temperatures in the current trial. This was due to the high ambient air temperatures, slow flow rate through the tanks and the long retention times in the pipe-work from the 'C' tanks to the barrels. The ocean water had further to travel through these pipes and was therefore often higher in temperature than the bore water, possibly explaining the slightly higher growth rate in this treatment. This problem was partially alleviated by purging excess water through the black polypipe to increase the flow rate and reduce the retention times.

The initial plan for this trial was to follow as closely as possible the design used in DF99-00. Unfortunately limited numbers of copepod nauplii were available, so similar nauplius densities could not be maintained. The low numbers of copepod nauplii available to the larvae during the early (and likely the most critical) stages was probably the primary reason why survival in this trial was significantly lower than obtained in DF99-00. It was, however, very encouraging to see the initial inoculations of copepod nauplii surviving to broodstock in a relatively short period and producing high numbers of nauplii. The peak nauplius densities obtained were excellent and if these numbers can be obtained during the early feeding stages then it is anticipated that significantly higher survival rates can be obtained. Options for achieving earlier peak nauplius densities from 'in-situ' broodstock are discussed in the general summary at the start of this report. Maintaining the desired density of *N. oculata* proved difficult with the pumping arrangement used in the current trial. This may have proved to be beneficial to the survival of the copepod nauplii, as some evidence has since been found which suggests that the nauplii may not perform as well in high concentrations of *N. oculata*.

DF00-02

**Provision of broodstock copepods Vs copepod nauplii.****Principal Investigator:** Mic**Broodstock History:** Wild Female A75A, Captive Males (D1+D3). Total eggs 26,000, Viability 96%, Fertilisation, 80%**Incubation Notes:** Large cone in 1 tonne tank. Survival to Day 2 was 77%.**Stocking:** Large tub placed underneath the hatching cone in 1 tonne tank and carried to the larval deck with a black plastic cover. Larval density was determined with aeration on in the hatching cone. Larvae were transferred from the cone to the barrels in a 2 L jug. Larvae were stocked into each of 12 x 160 L blue barrels at a density of 7.5/L (1,200 per barrel).**Rearing Methods:** Six blue barrels were suspended in both L7 and L8. Water from outside the barrels was pumped into the barrels via a powerhead such that each barrel received 200% water exchange daily. Water flowed out of each barrel via a standpipe screened with 53 um mesh. *N. oculata* was added daily to each of L7 and L8 to give a Secchi depth of 50-75 cm in each blue barrel. Between 1-3 litres of T-Iso was added to each barrel once daily. Barrels were lit from above with 400 W metal halide lamps approximately 2 m from the waters' surface. Barrels were covered with 2 layers of black shade cloth to give lux readings of 100-200 at the waters' surface.**Water Quality:****L7**

Temp. range	22.6°C - 23.9°C
Temp. mean	23.3°C
pH	7.8-8.1
Min. DO	99%
Max TAN	0.6 (pH 8.0, 22.9C)

**L8**

Temp. range	22.6°C - 24.4°C
Temp mean	23.5°C
pH range	7.8-8.0
Min DO	98%
Max TAN	0.55 (pH 8.0, 22.9C)

**Live food regime:** Barrels were set up as a live food trial with 3 replicates of 3 treatments as follows.

1. Copepod nauplii and rotifers each added to 5/ml (control)
2. Copepod broodstock added at a density of ?? (2250 ml)
3. Copepod broodstock added to a density of ?? and rotifers added to 10/ml

Copepod nauplii were topped up once daily. Rotifers were enriched with T-Iso for 6 h prior to feeding. Copepod broodstock were added 2 days before larvae were stocked.

In the control group rotifers soon exceeded 20/ml and copepod nauplii 0/ml. Intensive copepod cultures crashed hence no nauplii were available. Nauplius density in the second treatment did not exceed 1/ml throughout the trial. In the third treatment, rotifer density remained approximately 10/ml without the need to add further rotifers and copepod nauplii density did not exceed 1/ml throughout the trial.

**Growth:**

Day	2	5	8	11
Control	2.8	2.9	3.6	4.5
Copepod broodstock	2.8	3.1	3.6	4.4
Cop b/s + rot	2.8	3.1	3.7	4.3

**Transfers:** The trial was pulled down on Day 12, due to low survival and all remaining fish were pooled and transferred to a 1 tonne tank. Out of a total of 259 larvae, 173 (67%) survived the transfer process. Mortalities were probably the result of poor larval condition and rough handling of larvae from the first three barrels that were harvested.

**Weaning:** Remaining fish were combined with the remaining fish from DF00-03 and those from DF00-01 and weaned together, see DF00-01 for weaning details.

**Survival:** to Day 12:

Control	0.6%
Copepod broodstock	3.7%
Copepod b/s + rotifers	2.8%

**Comments/Problems/Suggestions for Improvements:**

The experimental system appeared to function well with the exception of initial light intensities in each barrel. At stocking, light intensities on the waters' surface were 400-1100 lux with lights 80 cm above the barrels and one layer of shade cloth over each barrel. Stocked larvae congregated on the surface where many died. The addition of a second layer of shade cloth and the raising of the lights (resulting in 100-200 lux) stopped this behaviour but not before many larvae had already died or become weak. Light intensities must be similar across all experimental tanks in future controlled experiments.

***Another problem with this trial was the lack of copepod nauplii available for the controls. Intensive copepod cultures must be made more reliable in the future.***

**DF00-03 Comparison of Microalgae V Algamac for rotifer enrichment.****Principal Investigator:** Sagiv**Broodstock History:** Wild Female A75A, Male ?? Total eggs 33,000, Viability 79%, Fertilisation, 80%.**Incubation Notes:** Eggs stocked for a passive V active stocking, was decided that there wasn't enough difference between the two methods. Eggs stocked into 6 small cones (2.5L). 1 cone into each of three blue barrels and three cones into a singles 1 tonne tank. Numbers surviving to Day 2 were:

1 tonne:	1	825
	2	980
	3	1230
barrels:	4	1192
	5	708
	6	575

**Stocking:** Cone numbers 1, 3 and 5 stocked into algamac treatments. Cones 2, 4 and 6 stocked into algae treatments. [WHICH TANK NUMBERS WERE WHICH TREATMENT??]**Rearing Methods:****Water Quality:** Heater chiller failure on 27<sup>th</sup> February, temperature reached 30°C.**Live food regime:****Growth:****Transfers:** After heater chiller failure the 48 remaining larvae were transferred to S6 where they were combined with the remaining fish from DF00-02.**Weaning:****Survival:** Prior to the heater chiller failure, numbers and survival in each tank were:

Tank #1:	0
Tank #2:	0
Tank #3:	0
Tank #4:	67
Tank #5:	37
Tank #6:	18

**Comments/Problems/Suggestions for Improvements:**

Survival between replicates was very different, hence there was no relationship to treatment (algamac vs algae enriched).

DF00-04

**Greenwater flow through with copepods I. High Nannno.****Principal Investigator:** Gavin & Mic.**Broodstock History:**

8/2/2000 Wild Female #3, Male D5, Total eggs 31,150, Viability 66%, Fertilisation, 75%.  
 9/2/2000 Wild Female #3, Male D5, Total eggs 28,600, Viability 60%, Fertilisation 85%  
 10/2/200 Wild Female #3, Male D1, Total eggs, 2,000, Viability 100%, Fertilisation 75%

**Incubation Notes:** All three batches incubated in large hatching cones in separate 1 tonne tanks in the dhufish larvae area. Number of larvae stocked from the hatching cones into the larval tank and survival to Day 2 from fertilised eggs were:

Batch 1:	8000	(52%)
Batch 2:	13,000	(89%)
Batch 3:	300	(15%)
Total	21,300	

**Stocking:** Large tub placed underneath hatching cones in 1 tonne tanks and this tub carried to the larval tank in the dark (covered with black plastic). Once in the LRT, the valve on the bottom of the large tub was cracked to allow slow acclimation of the larvae to the new conditions. During transfer and acclimation the light and skimmers were turned off.

**Rearing Methods:** A new method was trialled with this batch of fish. The rearing tank was maintained on a slow flow rather than being static. Larvae were reared in a 5 tonne tank (L4) with two additional 5 tonne tanks acting as algae and water (bore) reservoirs. The water reservoir was heavily aerated to remove CO<sub>2</sub> prior to flowing into the larvae tank. A small pump delivered algae from the algae reservoir to the water reservoir; the flow rate of the pump determining the algal density in the larval tank. Secchi depth was maintained at 50-70 cm. Water was pumped into a 300 L header tank from the water reservoir where it gravity fed into the larval tank. Increasing water exchange rates were based on maintaining unionised ammonia at <0.01 ppm. Water exchange rates were: 50% to Day 6, 75% to Day 13, 100% to Day 19, 125% to Day 22, 150% to Day 23, 175% to Day 28, 200% to Day 32. Light was provided by a single fluorescent tube with a range in surface light intensity from 110-200 lux. Two screens were placed on the outlet, 53µm and 250µm. The small screen ensured copepod nauplii remained in the tank. The large screen was set higher and acted as an emergency overflow in case the small screen became blocked. 50 L of high HUFA algae (*R. baltica* or T-Iso) were added daily until Day 29 as a food source for copepods and to provide enrichment for rotifers.

The theory behind this method was that the water quality would remain stable whilst maintaining the positive benefits of the static greenwater system. It was decided not to run a standard greenwater system because of our lack of experience in managing and manipulating water quality, algal density and food density with such a low density of larvae. Due to the importance in obtaining as many fish as possible for juvenile nutritional work it was decided that this was not a suitable time for experimentation with the standard greenwater system.



**Water Quality:** Temp. range: 21.3 °C – 23.6 °C  
 Temp. mean: 22.2 °C  
 pH range: 7.77 – 8.11  
 Min. DO: 89%  
 Max TAN: 0.69 ppm  
 Max NH<sub>3</sub>: 0.016 ppm

**Live food regime:** • Rotifers inoculated at 10/mL on Day 2. No further additions were made. Density peaked at 20/mL on day 10. At this stage some rotifers were harvested to reduce density.

• On Day 2 the tank was inoculated with 280,000 copepod broodstock and 790,000 copepodites. A lot of copepod broodstock could be seen on the tank walls in the early part of the run. Further additions of nauplii were made daily, these additions were usually of  $0.5 \times 10^6$  naups per day. Nauplii counts peaked at 1.1/mL (Day 19) and averaged 0.44/mL from Day 2 to Day 22.

• Artemia nauplii (Algamac enriched) fed from Day 15 at 0.01/mL, increasing to 0.1/mL by Day 30. Artemia fed three times per day to the required density. Ongrown Artemia and snapper larvae offered from Day 30.

**Growth:**

Day	2	4	6	8	10	12	14	16	18	20	22	24	26
TL	2.8	2.9	3.1	3.6	4.1	4.5	4.8	5.2	6.2	7.0	8.2	8.8	9.9

Growth rates experienced in the current trial were quite high (Figure 1), in light of the poor performance of the inoculated copepod broodstock and the low ingestion rate of nauplii and copepodites. The good growth rates cannot be explained in terms of temperature, which was similar to all other trials.

**Transfers:** Fish transferred to S1 for weaning on Day 41. L5 was drained to ankle depth and larvae tubbed out. 700 fish were transferred.

**Weaning:** Weaning commenced on Day 42. Weaning schedule is enclosed. Schedule involved decreasing the quantity of live ongrown Artemia from 20,000/day over a two week period, whilst offering chopped flesh in increasing quantities. High numbers of mortalities were occurring by Day 51 and larvae did not seem to be taking to the chopped flesh. At this stage live Artemia were being fed at 3,000/day. Due to the lack of acceptance of the chopped flesh the approach was reconsidered and live Artemia were increased back to 10,000/day. It was decided to introduce a 'middle step' between live Artemia and chopped flesh. Some ongrown Artemia were therefore frozen and offered to the larvae instead of chopped flesh. Due to the limited supply of live ongrown Artemia at the FMC, commercially available frozen ongrown Artemia were purchased. Mortalities decreased after this time due to the increase in live Artemia, however, strikes at the frozen Artemia were still very low. It was considered at this stage that more success might be achieved in smaller tanks and the larvae were therefore split into two 300 L tanks; 350 fish were moved. Mortalities in these tanks remained high for the first 4-5

days and then slowly dropped off. Fish were completely weaned onto chopped flesh by Day 78.

**Survival:** 3.33% to Day 41.

**Comments/Problems/Suggestions for Improvements:**

It was felt that the relatively poor performance of the larvae in the current trial was due to the lack of copepod production. In comparison to DF00-01, the current batch received a high broodstock inoculum, as well as daily additions of nauplii, however nauplius production was significantly lower than during DF00-01. The fact that limited numbers of broodstock copepods could be seen on the tank walls in the intermediate stages of the run indicated that the initial inoculum suffered high mortality before they began producing nauplii. The hypothesis behind the poor production in the current trial was the high density of *N. oculata*. This hypothesis was based on observations that nauplii in high density cultures of *N. oculata* appear sluggish. The following batch, DF00-05 sought to test this hypothesis by using a lower density of *N. oculata*. More detailed trials on copepods (without fish) have been planned to determine the optimum density and ratios of *N. oculata* with other high HUFA algal species for maximising copepod production. (See enclosed Project Proposal for details).

During the early parts of the trial, copepod nauplii were prevalent in the larvae's guts. By Day 10 rotifers became the predominant prey type. It was at this stage that rotifers were at their greatest density (~20/mL). Live food densities and gut content data were:

Day gut	Rotifer density	Nauplius density	Rotifer:Naup:Copepidite ratio in
5	12	0.2	2:7 : 1: 0
6	8	0.4	1.75 : 3.5 : 1
8	8	0.3	2 : 1.1 : 1
10	20	0.7	103 : 14 : 1
12	15	0.6	74 : 7.5 : 1
14	16	0.8	8.9 : 1 (couldn't tell naups from copes)

Although the copepod nauplius density increased with time, the relative contribution they made to the diet of the larvae decreased over time. Perhaps high rotifer densities (somewhere >8/mL) inhibit the larvae's search response for copepods and they simply eat what's most readily available to them. Specific trials comparing larval gut contents at varying rotifer densities, whilst maintaining a constant copepod density would be beneficial in determining whether high rotifer densities inhibit ingestion of copepods.

In previous cultures, dhufish larvae have been observed to change their orientation in the water column on ~Day 28 from pelagic to benthic. In the past the tank has been cleared of algae at this stage and the bottom of the tank vacuumed, leaving open the possibility that the fishes migration was the result of the tank clearing. In the current trial, however, the water remained green until Day 34 and the larvae still 'disappeared' on Day 28, indicating that the change in habitat is an ontogenetic

process which is not caused by a change in culture water turbidity or surface light intensity.

In addition, it has been assumed that high levels of mortality occur during the tank clearing stage as there often appears to be high numbers of larvae before the tank is cleared but not after. This led to the possibility that the mortality is caused by the stress of tank clearing and/or vacuuming. In the current trial, however, mortality still seemed to occur as the relatively high numbers of fish seen pre-migration were not seen again. The mortality may therefore coincide with some physiological change. This change may be a stressful event which some larvae may not tolerate and may highlight some nutritional deficiencies in earlier life. If future trials in 5 tonne tanks are able to obtain high densities of copepod nauplii in the early stages of the culture, it will be interesting to observe the pattern of post-settlement mortality, as these fish should not be nutritionally compromised in any way.

The final explanation is that high levels of mortality are not actually occurring and that there only *appeared* to be a lot of fish in the tanks during the greenwater stage as they are evenly distributed and close to the surface. The fact that mortalities cannot be seen in the greenwater tanks after they have been cleared supports this theory. It was previously assumed that the dead larvae were too small to be seen and/or decomposed very rapidly due to their small size.

Weaning proved difficult in the 1 tonne tanks, primarily due to the fact that the larvae remained low in the water column and would not come to the surface to feed. Weaning was more successful when the larvae were transferred to the 300 L tanks. In addition, it is believed feeding live ongrown Artemia also contributed to the difficulties experienced during the wean, as once the larvae began feeding on live Artemia it was difficult to transfer them onto either chopped flesh or frozen Artemia. Post-mortem of some mortalities taken during the weaning period found some bacterial infection of the gut, which could have been transferred from the live ongrown Artemia.

DF00-05

**Greenwater flow through with copepods II. Low Nanno..****Principal Investigator:** Gavin & Mic.**Broodstock History:**

9/3/2000 Female A404, Male D5, Total eggs 47,850, Viability 96%, Fertilisation, 25%.  
 10/3/2000 Female A404, Male D1, Total eggs 115,500, Viability 44%, Fertilisation, 71%.  
 11/3/2000 Female A404, Male D1, Total eggs 138,000, Viability 47%, Fertilisation, 61%.

**Incubation Notes:** Incubated in the larvae culture tank (L4) in three separate cones without light. Flow rate during incubation 50% (1.6 L/min). First batch reared in clear water until Day 1, then algae was added to the tank and the lights turned on. Once the first batch were stocked the remaining tanks were covered with Artemia cone lids. Number of fish stocked and survival to Day 2 from fertilised eggs were:

Batch 1: 600 (5.2% some deformed cell division observed)  
 Batch 2: 2200 (20%)  
 Batch 3: 1300 (3.35%)

An additional 5100 larvae were stocked into the larval tank which came from Bruce's bore V ocean trial. These larvae originally came from Batch 2. A total of 9200 Day 2 larvae were stocked into the tank.

**Stocking:** Batches 1, 2 and 3 stocked directly into the tank by inverting the hatch cones on Day 2. Bruce's larvae carried (covered) in the small hatch cones from the dhufish larval area to the larvae deck and then released through the screw top lid.

**Rearing Methods:** Larvae were reared using the same technique as the previous batch, however, in an effort to increase copepod production, less *N. oculata* and more high HUFA algae was used. A target secchi depth of 80-90 cm was set and 100 L of high HUFA algae was added daily.

**Water Quality:**

Temp range:	21.1°C – 22.7°C
Temp. mean:	21.6°C (Day 2 – 32)
pH:	7.62 – 8.19
Min. DO:	87% (Day 20)
Max TAN:	1.02 ppm
Max NH <sub>3</sub> :	0.02 ppm

**Live food regime:**

- Rotifers inoculated at 10/mL on Day 2. No further additions were made. Density peaked at 32/mL on day 21. Rotifers did not bloom to the levels normally seen during the early stages of the trial and the rotifer harvester was not required to reduce the density.
- On Day 2 the tank was inoculated with 780,000 copepod nauplii and 300,000 broodstock. No further additions of nauplii were made as none were available. Nauplii started appearing in the rotifer counts on Day 4. Nauplius density peaked on Day 12 at 1.4/mL and averaged 0.44/mL from Day 4 to 14. No nauplii were seen in the counts after Day 14.
- No Artemia nauplii were fed to this batch of larvae. Large numbers of broodstock copepods could be seen in the culture tank, therefore it was

decided not to feed the larvae on Artemia until the adult copepods had been depleted. Once depleted larvae were fed on ongrown Artemia.

**Growth:**

Day	4	7	11	13	16	19	23	25
TL	2.8	3.2	4.2	4.8	5.6	6.5	7.6	9.0

The growth rate of the current batch of larvae was very similar to the previous batch, DF00-04. This was somewhat surprising considering the far greater performance of the copepods in the current trial and the fact that larvae in this experiment were observed to be eating greater numbers of nauplii and copepodites. The mean temperature in the current trial was only 0.6°C cooler than the previous trial, unlikely causing a decrease in growth.

**Transfers:** 351 larvae transferred from the rearing tank to B3 for weaning on Day 33.

**Weaning:** It was decided to take a similar approach to weaning this batch as DF00-04 ie. provision of frozen ongrown Artemia as an intermediate step between live ongrown and chopped flesh. Feeding on live ongrown Artemia began on Day 35. Offering of frozen Artemia began on Day 44 however no interest was shown in the frozen Artemia until ~ Day 65 regardless of how and in which combination they were presented to the larvae. At this stage larvae were receiving ~15,000 live Artemia per day. As not many mortalities had occurred up to this stage it was likely that the level of live Artemia were sustaining the larvae. The rate of live Artemia decline was maintained until Day 71 when no more were offered. On Day 77 31 fish died, most likely those which were not adapted to feeding on the frozen Artemia. By this stage the larvae were feeding on frozen Artemia but showed little interest in chopped flesh. Frozen Artemia continued until Day 83 when larvae were finally weaned onto flesh.

**Survival** 3.81% to Day 33.

**Comments/Problems/Suggestions for Improvements:**

Similar inoculations of copepods were made in the current trial compared to the previous trial (DF00-04). The peak in nauplius production was similar in magnitude but occurred 7 days earlier in the current trial and observations of nauplii in live food counts ceased on Day 14 compared to Day 22 in the previous culture. The earlier peak in nauplius density indicates that the initial stocking of broodstock survived and produced nauplii suggesting that the algae feeding regime in the current trial was superior to that used in DF00-04. Likewise, the high numbers of broodstock seen in the later parts of the culture also illustrates the benefit of the current feeding regime. The earlier cessation of nauplius production was expected considering no further nauplii were added after the initial inoculum. The lower production of rotifers in the current trial could also have been due to the lower algal density.

Gut content data were:

Day	Rotifer Density	Nauplius Density	Rotifer:Nauplii:Copepodite (ratio in gut)
4	3	0.4	1 : 4 : 0
7	6	0	empty (8 am)
11	12	0.4	1 : 11 : 1.5
13	13	0.6	1 : 5 : 29
16	14	0	1 : 0 : 66

It was hypothesized that the high rotifer densities experienced in DF00-04 led to reduced intake of copepod nauplii. Similar rotifer densities were experienced in the current trial on Days 11 – 16 and ingestion of copepods was still very high. In light of this data, it is unclear as to why ingestion of copepods in the previous trial was so low, relative to that of rotifers.

Despite good copepod production and a high proportion of ingested food being copepods, survival was still significantly lower than obtained in DF99-00. The most plausible explanation for the poor survival is that the larvae did not receive enough nauplii during the early critical stages. During Mic's blue barrel experiment, nauplius density was maintained at ~ 4/mL until Day 19. After this stage nauplii were still available in the tank from in-situ production, however, no further nauplii were added. In the current trial nauplii were only available in the tank from Day 4 to Day 14 with an average density of 0.45/mL.

It is believed the difficulty in weaning was due to the late start and reluctance of larvae to wean off live ongrowns. The lack of mortality during the late stages of the wean, indicates that the rate of decline of live *Artemia* could have been faster.

**DF00-06**

***Aquamats static.***

**Principal Investigator:** Gavin.

**Broodstock History:** Wild female produced eggs on three occasions for stocking this trial.  
 1<sup>st</sup>) Captive male (D1). Total eggs 20,800; Viability 54%, Fertilisation 65%.  
 2<sup>nd</sup>) Captive male (D1). Total eggs 37,800; Viability 66%, Fertilisation 70%  
 3<sup>rd</sup>) Captive males (D1&D2). Total eggs 4,500; Viability 11%, Fertilisation ? Female had damaged ovaries by this stage.

**Incubation Notes:** Each batch stocked into a separate incubation cone (either 43 or 52L) within the larval rearing tank (L6).

**Stocking:** Each hatching cone stocked directly into the larval tank on Day 2 by gently inverting the cone. Numbers stocked and Day 2 survivals were:  
 1<sup>st</sup>) 4,300 larvae stocked; 38% - Many dead larvae seen floating on tank surface the following day.  
 2<sup>nd</sup>) 11,200 larvae stocked; 45%. - Larvae looked good the following day.  
 3<sup>rd</sup>) 200 larvae stocked; 40%.

**Rearing Methods:** Larvae were reared in a static greenwater tank with Aquamats. A target secchi depth of 60-80 cm of *N. oculata* was set, this required 200-250 L of 1 tonne culture per day. In addition 50 litres of high HUFA algae (either Rhodo or Iso) were added daily. Light intensity 10,000 lux from a single 400W metal halide, photoperiod 14:10. Due to the low ammonia readings, no water was added or replaced during the static phase. Flow (bore) was introduced on Day 24 @ 1 L/min, increasing to 8 L/min by Day 34.

**Water Quality:** Temp: 22.5 ± 0.1°C (Data logger installed: file c:\mydocs\backup\dhufish\df00-06.ttd)  
 Temperature maintained by digital thermostat.  
 pH: 7.20 – 8.2 (lowest end should probably be ~ 0.2 higher; calibration problems)  
 Min DO: 68% (Day 14)  
 Max TAN: 0.692 ppm (Day 11).  
 Max NH3-N: 0.009 ppm (Day 17).

**Live food types:**

- Rotifers stocked at 3/mL. Numbers had increased to ~50/mL by Day 10 and the harvester put on daily from then on to try and maintain numbers at ~30/mL. No enrichment other than the algae present in tank.
- ~100,000 broodstock calanoids added on Day 2. No further additions of calanoids. No calanoids seen in rotifer counts but were some nauplii seen in gut contents from Day 6 to Day 12.
- Many harpacticoid copepods present on Aquamats and seen in gut contents from Day 12.
- Small polychaete worms seen on mats but none seen in larval gut.
- Artemia nauplii (Algamac enriched) from Day 22. Consumption began as soon as they were introduced.

**Growth: (Ages are for the oldest fish)**

<b>Day</b>	<b>4</b>	<b>6</b>	<b>10</b>	<b>12</b>	<b>14</b>	<b>17</b>	<b>20</b>	<b>25</b>	<b>29</b>
<b>TL</b>	<b>2.9</b>	<b>3.2</b>	<b>3.9</b>	<b>3.9</b>	<b>4.3</b>	<b>4.8</b>	<b>4.9</b>	<b>6.4</b>	<b>8.2</b>

Growth rates of larvae in the current trial were the slowest of the batches reared this season. The reason for the low growth rates cannot be justified in terms of temperature or the presence or ingestion of copepods.

- Transfers:** 35 fish were transferred from the larval tank to a 300 L tank on Day 35.
- Weaning:** Not required
- Survival:** 0%. After fish were transferred there was a high mortality over the following days.

**Comments/Problems/Suggestions for Improvements:**

Many staff agreed that the tank looked excellent in the early stages and that there were many fish present. Lots of fish could be seen near the surface, in patches around the walls or directly under the light. Many fish were seen in the days following the low in DO (68%) indicating that this level of oxygen was not the cause of the drop out. Likewise many fish were also seen after the low in pH (7.2) was observed and there is evidence to suggest that pH only becomes harmful to marine fish larvae at levels below 6.0 (Brownell, 1980). On Day 21 not as many fish were seen and the high numbers were never seen again after this point. Initially the low numbers of fish observed after Day 21 was of no real concern, as dhufish larvae are known to change their position in the water column at this time from pelagic to benthic. It is therefore not known whether the high level of mortality actually occurred on this day, or if happened at some later stage, before the tank was cleared (Day 25). If the drop-out occurred close to Day 21 it may have co-incided with flexion, a potentially stressful event. If the nutrition of the larvae was inadequate, then the high levels of mortality may have occurred during flexion. This possibility, however, seems unlikely as previous static greenwater cultures, which received no high HUFA algae, or copepods, have yielded good results. It was observed during the transfer of larvae to the 300 L tank that there were many jellyfish medusa in the rearing tank. Jellyfish have not been seen in previous cultures with Aquamats, but have been seen in other tanks within the hatchery, perhaps suggesting they entered the tank through inadequately filtered water once the flow commenced. The bloom of the jellyfish may have been the cause of the mortality in the larvae.

It was very encouraging to see the ammonia remain at very low levels and to see the dhufish larvae consuming harpacticoid copepods. Given the apparent excellent survival during the most critical phase of the larval culture ie. the first 2-3 weeks, further work with dhufish larvae in the Aquamat system is worth pursuing. Future trials should concentrate on optimising the time at which flow should commence, when the tank should be vacuumed and ensuring the incoming water is adequately filtered.

It was proposed above that calanoid copepods could be cultured in the 5 tonne tanks on the larvae deck in order to ensure at least one tank has copepods at the maximum stage of production when larvae become available. The use of Aquamats in copepod cultures has the potential to increase production by providing additional substrate and providing alternative and additional sources of food. If it is decided to pursue the possibility of culturing copepods in 5 tonne



tanks, it is proposed that a replicated trial be conducted to compare copepod production in tanks with and without Aquamats. A proposal detailing this trial is enclosed.

**DF00-07**

**Replication of DF99-00**

**Principal Investigator:** Mic

**Broodstock History:** Wild Female, Male D1 and D2, Total eggs 41,250, Viability 88%, Fertilisation 55%.

**Incubation Notes:** Large hatching cone in dhufish larval area. Only 3680 larvae hatched. 1650 larvae stocked into each of two blue barrels (#1 & #2).

**Stocking:**

**Rearing Methods:** Similar methods to DF99-00. Secchi depth always greater than the tank depth. Daily additions of *R. baltica* (5-10 litres) and *N. oculata* (2 litres) made each morning, no algae was continuously pumped as in previous trials. Larvae were reared in bore water with a flow rate 0% to Day 5, 50% to Day 16, 100% to Day 28, 150% from thereafter. Tanks illuminated with a single fluorescent tube and covered with green shade cloth, giving a surface light intensity of ~ 150 lux. Each tank was heated with a 300 W aquarium heater.

**Water Quality:**

Temp. range:	#1:	18.5°C – 22.4°C.
	#2:	19.8°C – 24.5°C.
Temp. mean:	#1:	19.8°C.
	#2:	22.3°C.
pH range:	#1:	7.8 – 7.9
	#2:	7.8 – 7.9
Min. DO:	#1:	63% (Day 10)
	#2:	56% (Day 10)

**Live food regime:**

- Rotifers inoculated at 3/mL. No further additions made. Density peaked at 12/mL in both barrels on Day 12.
- Each tank inoculated with 3.5 nauplii/mL on Day 2. Further additions of approximately 1 nauplius/mL were made on Days 4, 5 and 6. One final addition of 0.4 nauplii/mL was made on Day 8. Density peaked at 3.5/mL in both barrels on Day 5 and averaged 1.5/mL and 2.34/mL from Day 5 to 13 for #1 and #2, respectively. Broodstock copepods visible on the tank walls from Day 13.
- Artemia nauplii (Algamac enriched) from Day 17, two feeds per day at 0.01/mL, increasing to three feeds per day of 0.1/mL by Day 35.

**Growth:**

Day	8	13	22
Total length	3.1	5.0	5.0

A growth rate of 5.0 mm to Day 13 is the best achieved this season. The reason for the lack of growth between Days 13 and 22 is unknown and

may have been due to a calibration problem with the microscope graticule.

**Transfers:** The two barrels were combined on Day 27, #1 had less fish than #2, 107 fish were transferred from #1 into #2. On Day 4, 61 fish were transferred from #2 to a 300 L tank (B1) for weaning. 16 mortalities occurred within 6 hours after the transfer with a further 21 over the following three days.

**Weaning:** Weaning commenced on Day 54, offered frozen ongrowns without any live ongrowns. Took to them well almost straight away. Maintained a feed rate of 3 x 0.1 nauplii/mL until Day 60 when number of feeds was dropped to 2 per day, then to 1 per day on Day 65. All eating frozen Artemia well by Day 65. Started offered chopped flesh on Day 65, some strikes seen on Day 66. No mortalities during the wean.

**Survival:** B1: 6.4% to Day 27.  
Overall: 1.8% to Day 41.

**Comments/Problems/Suggestions for Improvements:**

Survival in the current trial was poor, possibly due to the water quality parameters, in particular the low DO. In addition, the heater in tank #2 failed and increased the water temperature overnight from 19.8°C to 23.9°C, possibly resulting in high mortality. This batch again highlights the difficulty in maintaining good quality parameters in such small volumes.

Growth rate during the early stages was excellent, which was expected, considering relatively high numbers of copepod nauplii were maintained in the culture tanks during this time.

The ease of weaning this batch has been attributed to the early start and the lack of live ongrown Artemia. Larvae took quickly to both frozen ongrowns and flesh. It was thought that the low stocking density in the weaning tank may have made this batch difficult to wean, as there would be little competition for food and the larvae may not 'learn' from each other, however, this proved not to be the case.

## ***Appendix O Aquaculture Development Council of WA, Final Report***

### **Cultured copepods as food for West Australian dhufish (*Glaucosoma hebraicum*) larvae** Michael Payne, December 2000

#### **Summary**

Small-scale trials have determined that growth and survival of West Australian dhufish (*Glaucosoma hebraicum*) larvae is greatly increased by the provision of cultured copepods as food. As a result, intensive 1000 l copepod cultures have been established at the Aquaculture Development Unit (ADU; Fremantle, Western Australia). To date, production of nauplii from these intensive cultures has not been sufficient to supply large-scale larviculture operations. Increased numbers of nauplii may be achieved by stocking adult copepods into greenwater larviculture vessels. These adults produce nauplii that can be predated by larval fish. This study aimed to develop a greenwater technique that included copepods for rearing dhufish larvae on a commercial scale.

This study comprised six components, each summarised separately below.

#### **1. Copepod productivity in greenwater systems**

Adult copepods were stocked at 100/l and 200/l into greenwater systems comprising either *Nannochloropsis oculata* or *Dunaliella tertiolecta*. At 100/l and 200/l, nauplius density reached 4/ml and 5.5/ml, respectively, eight days after stocking. On the eighth day, the *Dunaliella* tank crashed, hence it was concluded that this alga was unsuitable for use in greenwater larviculture systems. Nauplius density remained at 5.5/ml in the *Nannochloropsis* tank for a further four days, suggesting that copepod productivity was 5.5 nauplii/ml/day. This production should support high growth and survival of dhufish larvae. *Nannochloropsis* appears to be a suitable species for use in copepod-greenwater larviculture systems.

#### **2. Growth and survival of dhufish larvae in small-scale greenwater systems**

Dhufish larvae were stocked into 220 l barrels incorporated into a greenwater system. Three live food treatments were tested; 1) copepod nauplii and rotifers maintained at 2/ml and 8/ml, respectively, 2) adult copepod stocked at the start of the trial and 3) adult copepods stocked at the start as well as rotifers maintained at 10/ml. Growth and survival were low in this trial, and it was terminated after 12 days. Poor larval performance was attributed to inappropriate larval acclimation procedures, high initial light intensities, late stocking of adult copepods and low nauplius production from intensive cultures.

#### **3. Growth and survival of dhufish larvae in large-scale greenwater systems**

Dhufish larvae were stocked into two 5000 l *Nannochloropsis* greenwater systems. In the first system, relatively high densities of *Nannochloropsis* were maintained along with low supplementary feeding with T-Iso. The second system was maintained with low *Nannochloropsis* densities and high T-Iso supplementation. Adult copepods were stocked into both systems at the same time as larvae. Growth was similar in the two systems and survival was 3.3% (day 41) and 3.8% (day 33) in the first and second systems, respectively. Larvae had a clear preference for copepod nauplii at first feeding. Rotifer predation appeared to increase when nauplius numbers decreased. *Artemia* nauplii were added in the first trial but not the second, as larger numbers of copepodids were available as food in the latter. This substantial copepodid population was attributed to the high level of T-Iso supplementation in this trial. Substantial mortality of *Artemia* fed juveniles in the first trial suggested bacterial infection or inappropriate enrichment. Low survival rates were attributed to late stocking of adult copepods and insufficient supplementary feeding with T-Iso.

#### 4. Replication of a successful dhufish rearing trial from the previous season

Two 220 l larviculture barrels were established using similar protocols that were successful in the previous season. However, nauplius production from intensive cultures was low, hence rates of nauplius provision could not be replicated. Dhufish survival appeared high during the early part of the trial when nauplii were reasonably abundant. However, on day 41 average survival was 1.8% and growth was very slow. Low pH and DO were recorded in this trial. This, along with low nauplius availability, was the likely cause of poor dhufish performance.

#### 5. Improvement of intensive copepod culture techniques

Copepod cultures at ADU are often invaded by harpacticoid copepods and fed with contaminated algae. Dedicated copepod and algal culture rooms were established at ADU. Also, the copepod culture regime was altered to include diluted seawater rather than full strength seawater. Nauplius production from intensive cultures improved markedly with these improvements. A major contaminant of algal cultures was determined as a heterotrophic haptophyte. In a controlled trial, copepod survival was reduced when fed this haptophyte compared to T-Iso.

#### 6. Evaluation of a dinoflagellate as food for cultured copepods

Copepods were fed three diets under controlled conditions; 1) the dinoflagellate *Heterocapsa niei*, 2) T-Iso, and 3) a mixture of both. Copepod maturation time was fastest on a diet of *Heterocapsa*, followed by the mixed diet and then T-Iso. This suggests that *Heterocapsa* has the potential to improve productivity of copepod cultures. Over a 10 month period, a strain of *Heterocapsa* was produced that will grow on f/2 media. This makes culture of this alga more convenient and cheaper. Further work is required to determine the effect of this alga on copepod fecundity and nutritional content.

The project did not fulfil its primary objective, which was to successfully incorporate copepods into commercial-scale larviculture practices for dhufish. However, significant progress was made in this direction, as well as in improving the reliability and magnitude of nauplius production from intensive copepod cultures. This will greatly assist the establishment of a copepod-greenwater system in the upcoming (2000/2001) dhufish larviculture season.

#### **Acknowledgements**

Firstly, I wish to thank the Aquaculture Development Council for their support in this project. I would also like to acknowledge the considerable assistance I have received from the Department of Environmental Biology at Curtin University. Thanks to Rob Rippingale for help above and beyond the call of duty.

I would particularly like to thank Mr Greg Jenkins, Mr Ken Frankish, Dr Jennifer Cleary and Mr Gavin Partridge of ADU for all their assistance and co-operation. To all the support staff at ADU, I would also like to extend my gratitude.

<b>Table of contents</b>	
<b>Summary</b>	<b>120</b>
<b>Acknowledgements</b>	<b>121</b>
<b>Table of contents</b>	<b>122</b>
<b>1.0 General introduction</b>	<b>124</b>
<b>2.0 Copepod productivity in greenwater systems</b>	<b>125</b>
2.1 Introduction	125
2.2 Materials and Methods	125
2.3 Results	125
2.4 Discussion	127
<b>3.0 Growth and survival of dhufish larvae in small-scale greenwater systems</b>	<b>128</b>
3.1 Introduction	128
3.2 Materials and Methods	128
3.3 Results and Discussion	128
<b>4.0 Growth and survival of dhufish larvae in large-scale greenwater systems</b>	<b>131</b>
4.1 Introduction	131
4.2 Materials and Methods	131
4.2.1 Stocking techniques and live food regime for DF00-04	131
4.2.2 Stocking techniques and live food regime for DF00-05	132
<b>5.0 Replication of a previous successful dhufish rearing trial (DF99-00)</b>	<b>138</b>
5.1 Introduction	138
5.2 Materials and Methods	138
5.3 Results	138
5.4 Discussion	138
<b>6.0 Improvement of intensive copepod culture techniques</b>	<b>139</b>
6.1 Introduction	139

6.2 Materials and Methods	139
6.3 Results	141
<b>7.0 Evaluation of a dinoflagellate as food for cultured copepods</b>	<b>143</b>
7.1 Introduction	143
7.2 Materials and Methods	143
7.2.1 Copepod maturation	143
7.2.2 Culture media for <i>Heterocapsa</i>	143
7.3 Results	143
7.4 Discussion	144
<b>Conclusions and Recommendations</b>	<b>145</b>
<b>References</b>	<b>146</b>

## 1.0 General introduction

The Aquaculture Development Unit (ADU; Fremantle, Western Australia) has been developing culture techniques for temperate marine finfish for the past 9 years. In this time, a highly successful culture technique has been standardised for commercial fingerling production of black bream (*Acanthopagrus butcheri*) and pink snapper (*Pagrus auratus*). Better than 50% survival of pink snapper from hatchling to day 35 is achieved with this semi-intensive greenwater technique.

West Australian dhufish (*Glaucosoma hebraicum*) is one of West Australia's premier table fish and as such has a high market value. Recently, ADU has commenced research on the culture of this species. However, larviculture techniques used to rear black bream and pink snapper currently do not provide for high survival rates in dhufish. Alternative rearing strategies may result in improved survival rates for this species.

Rotifers are provided as the sole diet for first feeding larvae in most larviculture systems, including the semi-intensive technique used at ADU. Pink snapper larvae are readily reared on rotifers hence the success of this technique for this species. In contrast, high mortality of dhufish larvae in the greenwater system suggests that rotifers may not be an appropriate food for these larvae.

In 1998/1999, intensive cultures of the calanoid copepod *Gladioferens imparipes* were established at ADU as part of an FRDC funded project (No. 96/398). Copepods collected from these cultures were used to feed larval dhufish (batch DF99-00) in a small-scale trial. Survival (to a length of 11 mm) in those larvae reared on a combined diet of copepods and rotifers was 37%, compared to 5% for those reared using rotifers only (Payne *et al.*, in press). Growth in larvae fed the combined diet was also significantly faster. These increases were attributed to increased feeding by dhufish larvae on copepod nauplii and their high nutritional content.

Currently, large scale calanoid copepod production systems established at ADU cannot match the production of large scale rotifer cultures. This is also true of other calanoid copepod culture systems (Støttrup *et al.*, 1986; Schipp *et al.*, 1999). It is clear that intensive copepod cultures alone cannot produce enough copepod nauplii to supply commercial scale larviculture. Alternative strategies for supply of copepods to these systems are required.

During the previous dhufish larviculture trial (DF99-00), it was noted that uneaten copepod nauplii were retained in larviculture vessels. Algae, added to each larviculture vessel to maintain nutritional content of live food and increase water turbidity, provided food for these uneaten copepods, allowing them to grow rapidly. Adult copepods were too large to be predated by early dhufish larvae and soon commenced reproduction. Thus, in this trial, larval dhufish fed on both copepod nauplii added from external intensive cultures, as well as those produced by copepods that had grown to maturity in the larviculture vessels. This suggests that the supply of copepod nauplii to larval dhufish may be increased by early addition of adult copepods to the standard greenwater larviculture technique used at ADU. This is equivalent to stocking larvae into an intensive copepod culture maintained in a commercial-scale larviculture vessel.

### 1.1 Objectives

Establish protocols for the use of copepods in commercial scale greenwater larval culture systems. This requires the determination of initial copepod stocking density, larval fish stock density, algae feed rate, water exchange rate, temperature and management of suspended and settled solids.

Determine the efficacy of greenwater systems with varying combinations of rotifers and copepods for rearing WA dhufish. Combinations will include larval diets consisting of 50% rotifers:50% copepods, 25% rotifers:75% copepods and 100% copepods.



## 2.0 Copepod productivity in greenwater systems

### 2.1 Introduction

Standard greenwater techniques used at ADU require the addition of the microalga *Nannochloropsis oculata* to larviculture tanks. Previous work has shown that a monodiet of *Nannochloropsis* does not support good growth and survival in *G. imparipes* (Payne and Rippingale, 2000). Therefore, this microalga may not be appropriate for use in greenwater systems that include copepods. This previous study also found that in contrast to *Nannochloropsis*, the green microalga *Dunaliella tertiolecta* did support good growth, survival and fecundity in *G. imparipes*. *Dunaliella* is a hardy species that may be a suitable replacement for *Nannochloropsis* in ADU greenwater systems. The aim of this trial was to determine this by comparing copepod fecundity in greenwater systems using *Dunaliella* and *Nannochloropsis*. Neither of these algal species contain significant amounts of the fatty acid DHA, which is an essential nutrient for both copepods and larval fish. DHA was provided to all treatment animals in this study via supplementary feeding with small quantities of the microalga *Isochrysis galbana* (T-Iso).

### 2.2 Materials and Methods

This experiment was conducted in two 5000 l cylindrical tanks with conical bottoms located at ADU. Both tanks were illuminated by 400 W metal halide lamps on a 12L:12D cycle. Tanks were filled with seawater obtained from a marine bore and heated to  $21 \pm 0.5^\circ\text{C}$ . Six 220 l plastic barrels were suspended in each tank such that each contained 160 l of water. Water on the outside of the barrels was pumped into each barrel such that each received 170% daily exchange. Water left each barrel via a central drain in the base that was screened with 53  $\mu\text{m}$  mesh in order to retain copepod nauplii within the barrel. Each barrel was subject to gentle, coarse aeration and was covered with shade cloth to reduce light intensity.

Both species of microalgae were grown in 1000 l outdoor tanks using the soluble plant fertiliser Aquasol<sup>®</sup> (Hortico) as the nutrient medium. One 5000 l tank was stocked with *Dunaliella* and the other with *Nannochloropsis*. Secchi disk depths of 60-70 cm were maintained in both 5000 l tanks by daily addition of algae. Copepods (late copepodid and adult stages; C4-C6) were stocked into each 220 l barrel at two experimental densities. In both the *Dunaliella* and *Nannochloropsis* tank, three randomly selected barrels were stocked with 100 copepods/l. Remaining barrels were stocked with 200 copepod/l. All barrels were provided with the same amount of T-Iso as a supplementary feed. This alga was added once daily to a density of  $2-3 \times 10^4$  cell/ml in each barrel. It was expected that most of this would be consumed by the copepods before it was flushed from each barrel. Barrel outlet screens were cleaned daily.

Copepods were maintained in the barrels for four days without disturbance, other than feeding with T-Iso. On the fifth day, daily measurement of nauplius density commenced. This was achieved in each barrel by collecting three subsamples of 1 l each while aeration was increased for a brief period. Subsamples were pooled and the volume reduced (with nauplii retained) to approximately 500 ml. From this sample, the number of nauplii in each of multiple 1 ml volumes removed during vigorous mixing were determined. Averaged results for each sample were used to calculate nauplius density in the corresponding barrel.

Throughout the nauplius sampling period, much of the *Dunaliella* added to the 5000 l tank had settled to the bottom within 4 hours. On the eighth day of the trial, this tank was completely clear with much sediment of the bottom. Sampling ceased on this day. No settlement of algae was observed in the *Nannochloropsis* tank and nauplius sampling continued until day 12. On this day, copepods remaining in each barrel in the *Nannochloropsis* treatment were counted.

### 2.3 Results

Fig 2-1 shows that nauplius density increased rapidly in all treatments on the seventh day. At each copepod stocking density, nauplius densities on day 8 were not significantly different between algal treatments. In treatments with copepods stocked at 100/l, nauplius density attained  $4 \pm 0.6/\text{ml}$  on day 8 in both *Dunaliella* and *Nannochloropsis* systems. With copepods stocked at

200/l, nauplius density on day 8 was  $5.5 \pm 0.9$ /ml in both systems. These densities were significantly different ( $p < 0.01$ ).

Rapid settlement of *Dunaliella* on day 8 resulted in the termination of this treatment. In the *Nannochloropsis* greenwater system, nauplius density from days 8 to 12 remained relatively constant at 4/ml and 5.5/ml with initial copepod stocking densities of 100/l and 200/l, respectively. Counts of total copepod numbers in *Nannochloropsis* treatments (Table 2-1) at the completion of the trial indicates that copepodid and adult densities had increased markedly from the original stocking.

A)  
B)

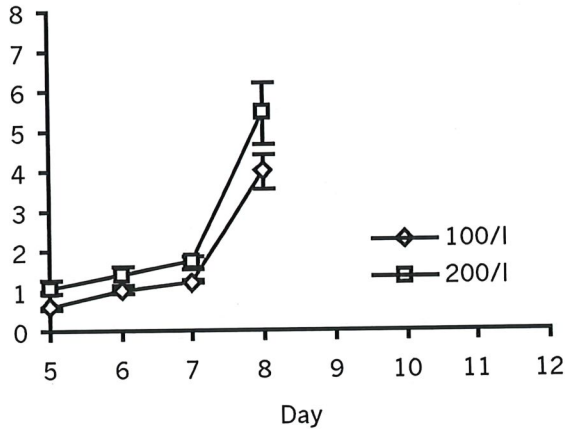

Fig 2-1. Nauplius density in greenwater tanks comprising *Dunaliella* (A) and *Nannochloropsis* (B). Adult copepods were stocked at two different densities, 100/l and 200/l. Data represented as mean  $\pm$  sd.

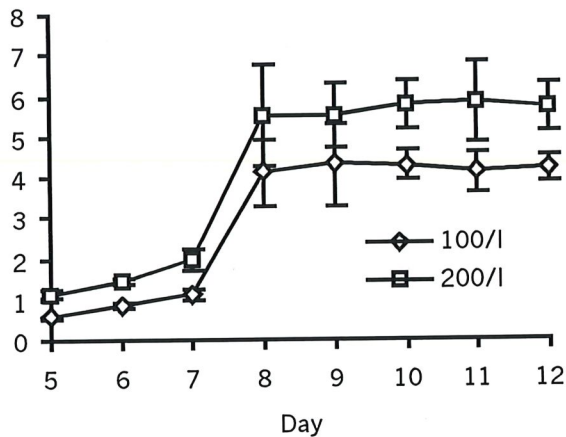

Table 2-1. Final (day 12) densities of nauplii, copepodids and adult copepods in *Nannochloropsis* greenwater treatments (mean  $\pm$  sd).

Initial adult stocking density	Nauplii (per ml)	Copepodids (per ml)	Adults (per litre)
100/l	4.1 $\pm$ 0.6	5.4 $\pm$ 0.1	221 $\pm$ 52
200/l	5.6 $\pm$ 0.5	5.9 $\pm$ 1.1	258 $\pm$ 33

## 2.4 Discussion

Equal nauplius densities on day 8 between *Dunaliella* and *Nannochloropsis* treatments indicate that use of *Dunaliella* in greenwater systems does not greatly increase fecundity in *G. imparipes* as expected. Further, this microalgae did not stay in suspension after 8 days. In greenwater larviculture tanks, microalgae serves an important purpose in altering the lighting regime, thereby increasing feeding incidence by larval fish (Naas *et al.*, 1992). Rapid settlement suggests that *Dunaliella* would not fulfil this purpose. This settlement is explained by the large cell volume of *Dunaliella*, making it difficult to keep in suspension. In contrast, *Nannochloropsis* cells are 10% of the volume of *Dunaliella* cells (Payne and Rippingale, 2000) and thus are readily maintained in suspension in the low turbulence environment of larviculture systems. Furthermore, this alga does not appear to limit fecundity in *G. imparipes* when T-Iso is also available. These results suggest that *G. imparipes* can be successfully incorporated into greenwater larviculture systems that make use of *Nannochloropsis*. In this study, the amount of T-Iso supplementation was limited by unreliable algae production. Further work will determine the optimum amount of supplementation with T-Iso (or another microalga high in DHA) required for maximising copepod fecundity and nutritional content.

In *Nannochloropsis* treatments, nauplius density remained constant after 8 days. As for all calanoid copepods, *G. imparipes* has six nauplius (N1-N6) followed by six copepodid (C1-C6) life history stages. C6 is the adult stage. Nauplius stages of *G. imparipes* are fully pelagic, whereas some of the copepodid stages spend much of their time attached to substrate. In the present work, only the increase in pelagic nauplii was measured. As these nauplii developed into copepodids and attached to the internal walls of the barrels, they were no longer sampled. Therefore constant nauplius densities in *Nannochloropsis* treatments indicate that each day, the number of nauplii produced (available for sampling) equals the number of nauplii that have developed into copepodids (no longer available for sampling). This concept is supported by the substantial increase in copepodid and adult stages recorded on day 12 of this trial.

On any given day, nauplius density in barrels stocked at 200/l could be expected to be twice that observed in barrels stocked at 100/l. This did not occur in the present study. As mentioned previously, some stages of *G. imparipes* attach to substrate. At high population densities, individuals are likely to compete for internal surface space on which to settle. Increased competition at these densities may result in decreased fecundity. Provision of greater internal surface area in culture vessels will probably reduce competition and increase productivity. This is currently being investigated at ADU.

These results are very encouraging as they indicate that even at an initial copepod stocking density of 100/l, 4 nauplii/ml are produced daily. In the previous study that recorded 37% survival in dhufish larvae fed a combined copepod/rotifer diet (DF99-00), larvae were stocked at 6/l and copepod nauplii were maintained at 5/ml (Payne *et al.*, in press). In that trial, not all nauplii were consumed each day, hence the feed rate was less than 5 nauplii/ml/day. The present study indicates that *in situ* nauplius production by adult copepods in a *Nannochloropsis* greenwater larviculture system that is supplemented with T-Iso may be sufficient to support high survival in dhufish larvae.

### 3.0 Growth and survival of dhufish larvae in small-scale greenwater systems

#### 3.1 Introduction

Previous studies have indicated that copepods may be an effective addition to standard greenwater larviculture techniques used at ADU. Inclusion of copepod nauplii in the diet of dhufish larvae increases growth and survival in 220 l containers, as demonstrated in the 1998/1999 season with batch DF99-00. In greenwater vessels of the same volume that utilise mostly *Nannochloropsis*, with a small daily supplementation of T-Iso, *in situ* nauplii production from stocked adult copepods is high. *In situ* nauplius production in these conditions should be sufficient to support high growth and survival in dhufish larvae without the need for further addition of nauplii collected from intensive cultures. This trial aimed to test this hypothesis using 220 l larviculture tanks.

#### 3.2 Materials and Methods

This trial was conducted using the same experimental equipment described previously in Section 2.2. *Nannochloropsis* was added to both 5000 l tanks to a Secchi depth of 50-75 cm and this turbidity was maintained throughout the trial. T-Iso was added to each barrel daily as described previously. Each barrel received gentle aeration and was subject to 200% daily water exchange. Initially, each barrel was covered with one layer of shade cloth to give a light intensity of 400-1000 lux at the water surface. However, another layer of shade cloth was added after larvae were observed crowding near the surface immediately following stocking. This reduced light intensity to 100-200 lux. Water quality, monitored regularly in both 5000 l tanks, was as follows;

	Tank L7	Tank L8
Temp range	22.6-23.9°C	22.6-24.4°C
Temp mean	23.3°C	23.5°C
pH	7.8-8.1	7.8-8.0
Min DO	99%	98%
Max NH <sub>3</sub>	0.02ppm	0.02ppm

Three live food treatments were tested;

1. Copepod nauplii and rotifers maintained at 2/ml and 8/ml, respectively (control)
2. Copepods stocked at the commencement of the trial at 274/l (C1-C4) and 80/l (C5-C6)
3. Copepods stocked as for treatment 2 and rotifers maintained at 10/ml

Copepodids and adult copepods were stocked two days prior to the addition of larvae. Live prey densities in treatments 1 and 3 were measured and adjusted daily. Rotifers were enriched with T-Iso for 6 hours prior to use.

Day 2 post-hatch dhufish larvae were stocked into each barrel at a density of 7.5/l (1200/barrel). The standard length of three larvae from each barrel was measured every 3 days.

#### 3.3 Results and Discussion

Generally poor survival was recorded in all treatments (Fig 3-1). The trial was terminated on day 12 because of this poor survival. Fig 3-1 shows that growth was not significantly different between all treatments. On day 11, mean length for all treatments was  $4.4 \pm 0.2$  mm compared to  $5.1 \pm 0.2$  mm obtained by larvae of batch DF99-00 at the same age.

There are several possible explanations for poor survival recorded in this trial. Larval quality was likely to be high, as indicated by 80% fertilisation and 96% viability rates for this batch. However, there may not have been sufficient acclimation time during transfer of larvae from hatching cones to the separate larviculture barrels. Minutes after larvae had been added to the barrels, numerous dead larvae were observed floating on the surface. Added stress may have resulted from the process of obtaining accurate counts of larvae in the hatching cones prior to transfer. The acclimation process would not be necessary if hatching cones were placed directly in the larviculture tank rather than kept in separate systems.

Early mortality of larvae may have been caused by high light intensities at first stocking. Lowering the intensity by adding another layer of shade cloth did reduce crowding behaviour but not before larvae had been subject to stressful conditions. More work is required on the optimum light intensity for culturing dhufish larvae.

A)

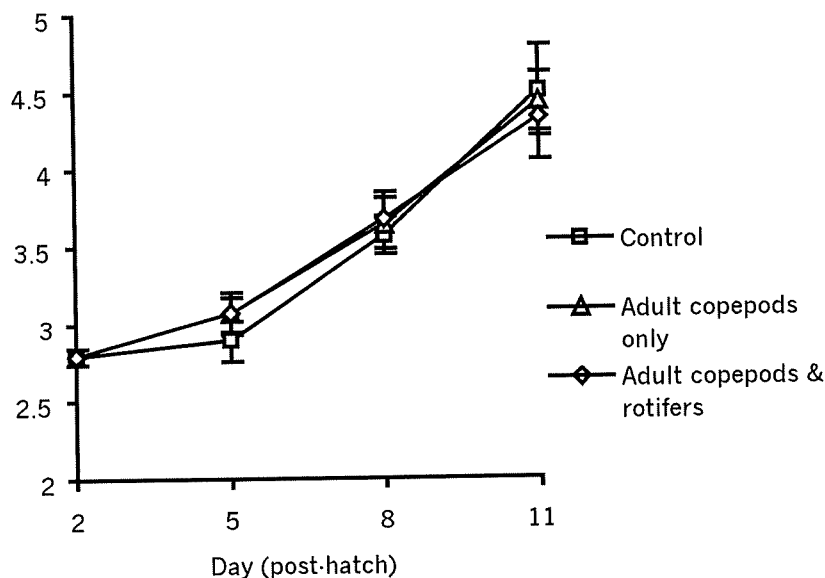

B)

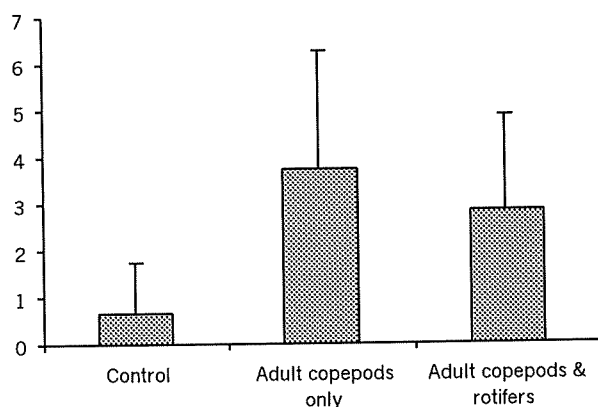

Fig 3-1. Growth (A) and survival (B) of larval dhufish in greenwater systems with different live food treatments; copepod nauplii maintained at 2/ml and rotifers maintained at 8/ml (control), adult copepods added at the commencement of the trial, and adult copepods and rotifers maintained at 10/ml. Survival data was recorded on day 12 post-hatch. All data presented as mean ± sd.

Another problem with this trial was the lack of copepod nauplii available from intensive cultures. It was intended that the control diet consist of 5 copepods/ml and 5 rotifers/ml, as used by Payne *et al.* (in press) to achieve high dhufish survival. However, 1000 l copepod cultures at ADU were not productive at this time, hence only 2 copepods/ml could be provided. Also, adult copepods were stocked into barrels only two days before larvae. Results of a previous section showed that nauplius densities increased 8 days after stocking. Transition from endogenous to exogenous feeding (often called the first feeding stage) is a critical phase during which substantial larval mortality can occur. Larvae would probably benefit greatly from high availability of copepod nauplii at the first feeding stage. In the present study, first feeding larvae probably had limited access to copepod nauplii for the first 6 days. In the future, adult copepods must be stocked into larviculture vessels well before the larvae.

Despite poor survival, it was encouraging to record some dhufish survival in barrels that had been stocked with adult copepods only. This result indicates that adult copepods can be stocked directly into dhufish larviculture tanks to provide *in situ* nauplius production.

## 4.0 Growth and survival of dhufish larvae in large-scale greenwater systems

### 4.1 Introduction

The previous trials have indicated that copepods added to greenwater systems comprising *Nannochloropsis* with supplementary feeding of T-Iso produce enough nauplii to support survival and growth in larval dhufish. However, a number of juvenile dhufish must be produced this season to enable further research on grow-out techniques for this species in the next season. Rather than risk repeating the poor success of the previous trial, two 5000 l dhufish cultures were established. The primary aim of these cultures was to produce enough fish for later grow-out trials. Both cultures were modified versions of the standard greenwater larviculture techniques used at ADU, with addition of adult copepods. In the first trial (dhufish batch DF00-04), relatively high amounts of *Nannochloropsis* and low amounts of T-Iso were used. In the second trial (batch DF00-05), quantities of *Nannochloropsis* were decreased and T-Iso was increased.

### 4.2 Materials and Methods

Two trials were conducted sequentially in two separate tanks with batches DF00-04 and DF00-05. Both larviculture tanks were established as flow through, in contrast to the usual ADU techniques, which are static during the initial period. This approach was adopted as dhufish larvae appear to be sensitive to the relatively high ammonia concentrations and low pH values that are typical of static greenwater systems. Also, dhufish larvae may not be tolerant of the high light intensities required to maintain the health of algae in static systems. Flow through was established by continuously mixing clean water and *Nannochloropsis* in a separate 5000 l tank. This mixture was then recirculated to a header tank, from which a proportion flowed to the larviculture tanks. Outlets on the larviculture tanks were screened with 53µm mesh. Flow through commenced at 50% daily exchange and increased gradually to a maximum of 200% on day 29. Algae was added to larviculture tanks at the following rates;

	DF00-04	DF00-05
<i>Nanno</i> ' density (Secchi)	High (50-70cm)	Low (80-90cm)
T-Iso supplementation	Low ( $1-2 \times 10^4$ cells/ml/day)	High ( $3-5 \times 10^4$ cells/ml/day)

*Nannochloropsis* density in larviculture tanks was adjusted by carefully adjusting the flow of *Nannochloropsis* into the premix tank. T-Iso (or *Rhodomonas baltica* if T-Iso was unavailable) was added daily to each tank.

Overhead light was provided by a single fluorescent tube on a 14L:10D cycle. Light intensities at the water surface were approximately 200 lux in the centre of the tank and 110 lux at the sides. Nine airstones suspended off the bottom provided water movement and aeration. Surface films were removed by two surface skimmers that were cleaned twice daily. Water quality throughout the trials was as follows;

	DF00-04	DF00-05
Temp range	21.3-23.6°C	21.1-22.7°C
Temp mean	22.2°C	21.6°C
pH	7.77-8.11	7.62-8.19
Min DO	89%	87%
Max NH <sub>3</sub>	0.016ppm	0.02ppm

In both trials, larval dhufish were stocked on day 2 post hatch, and adult copepods were stocked on the same day. However, larval stocking techniques and live food regimes were different for each culture.

#### 4.2.1 Stocking techniques and live food regime for DF00-04

In this trial, larvae were hatched in a separate system. Larvae were transferred to the larviculture tank in their hatching cone, which was floated in the tank. Gradual water exchange between cone and tank ensured slow acclimation.

Immediately prior to larval stocking, 280,000 adult copepods (62/l) and 790,000 copepodids (175/l) were added to the larval culture tank. Rotifers were also stocked at 10/ml and maintained around this density up to day 19. High rotifer densities necessitated their daily removal between days 10 and 14. Copepod nauplii, collected from intensive cultures, were added at the rate of approximately 0.1 nauplii/ml/day up to day 19. *Artemia*, enriched with Algamac 2000, were fed at the rate of 0.01 *Artemia*/ml/day from day 15, increasing to 0.1 *Artemia*/ml/day on day 30. *Artemia* were added three times daily. After day 30, on-grown *Artemia* and newly hatched pink snapper larvae were provided as food.

#### 4.2.2 Stocking techniques and live food regime for DF00-05

Larvae were hatched in cones floated in the larviculture tank, hence no acclimation was necessary at stocking.

Immediately prior to larval stocking, 300,000 adult copepods (66/l) and 780,000 nauplii (173/l) were added to the larviculture tank. Rotifers were also added at 10/ml and maintained around this density up to day 23. No further additions of copepod nauplii were made as intensive cultures were not productive at this time. *Artemia* nauplii were not fed to larvae in this culture. After day 20, larvae continued to feed on adult copepods. After day 37, larvae were fed on-grown *Artemia*.

#### 4.3 Results

Fig 4-1 shows that growth of dhufish larvae in batches DF00-04 and DF00-05 was not significantly different. Batch DF00-04 did grow slightly faster. Growth rates in both batches was considerably less than in a previous trial (DF99-00) in which dhufish were reared on a diet comprising copepod nauplii and rotifers both maintained at 5/ml in 220 l barrels. Survival of dhufish in batches DF00-04, DF00-05 and DF99-00 were as follows;

	DF00-04	DF00-05	DF99-00
Survival	3.3% (day 41)	3.8% (day 33)	37.1% (day 28)

As with growth, dhufish survival was similar in batches DF00-04 and DF00-05, and both were considerably less than batch DF99-00. Substantial larval mortality from days 21-42 was recorded

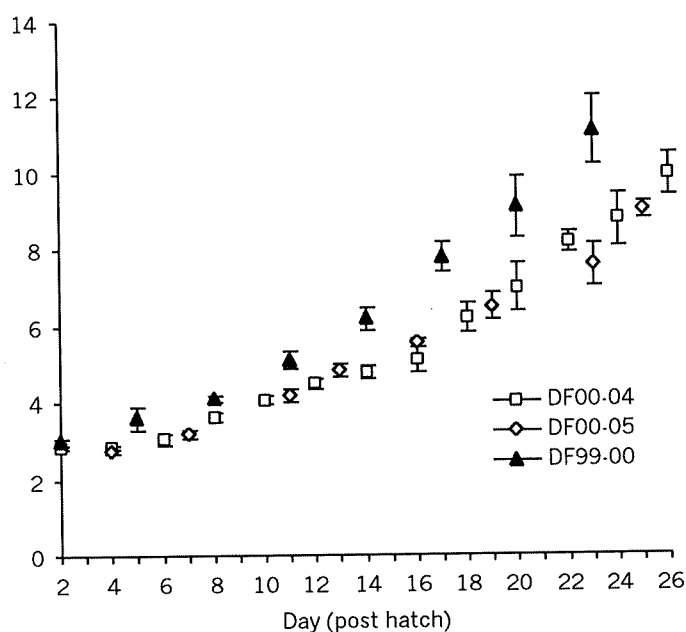

in DF00-04 but not 05.

Fig 4-1. Growth of dhufish reared in two 5000 l greenwater larviculture vessels. DF00-04 received high *Nannochloropsis* and low T-Iso, while DF00-05 received low *Nannochloropsis* and high T-Iso. Data from a previous trial (DF99-00) indicates the fastest growth rate yet achieved for dhufish larvae. Data presented as mean  $\pm$  sd.



Patterns of prey selection were different between the two batches (Fig 4-2). In both batches, rotifers were predated up to day 22-23 and copepod nauplii up to day 14-16. Rotifers were a substantial proportion of the gut content in batch DF00-04 but not in DF00-05. Rotifer densities were generally high in both systems (Fig 4-3). First feeding dhufish larvae preferentially selected copepod nauplii over rotifers. In both trials, few copepod nauplii were available to these larvae (Fig 4-3) yet they comprised most of the prey in the gut (Fig 4-2). Nauplius densities remained below 1/ml throughout both trials (Fig 4-3). Copepodids were a substantial component of dhufish gut content in batch DF00-05 but not in DF00-04. Larvae in batch DF00-04 preyed almost exclusively on *Artemia* from day 22.

A)

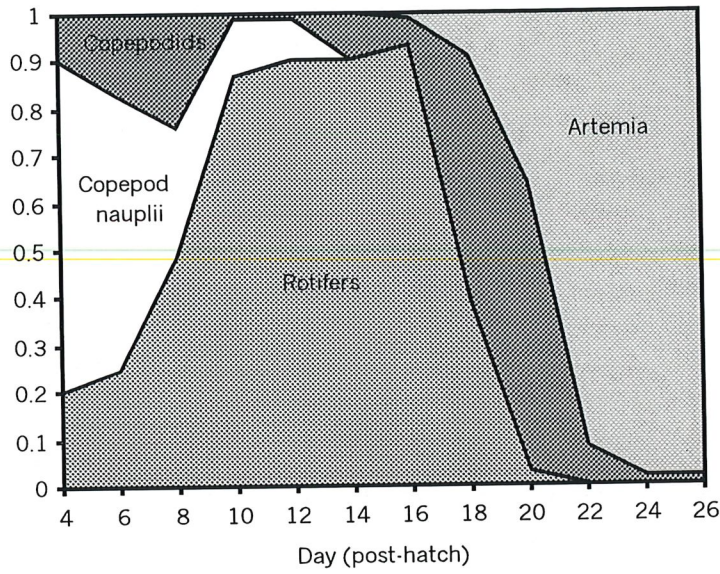

B)

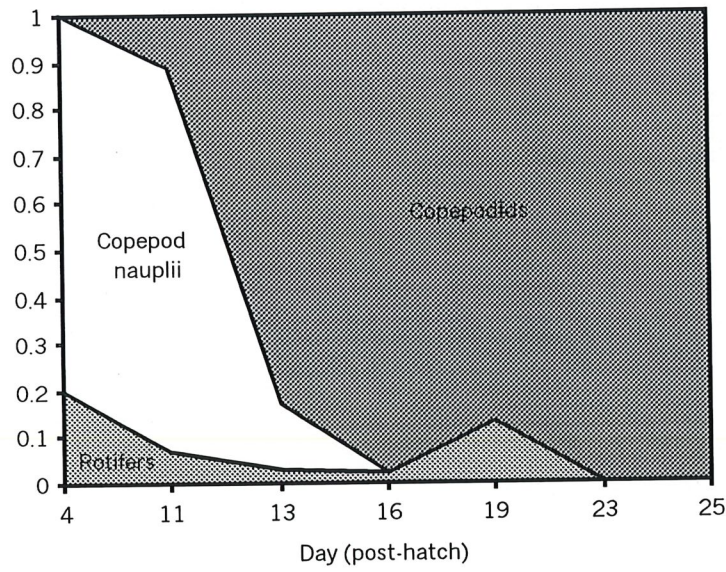
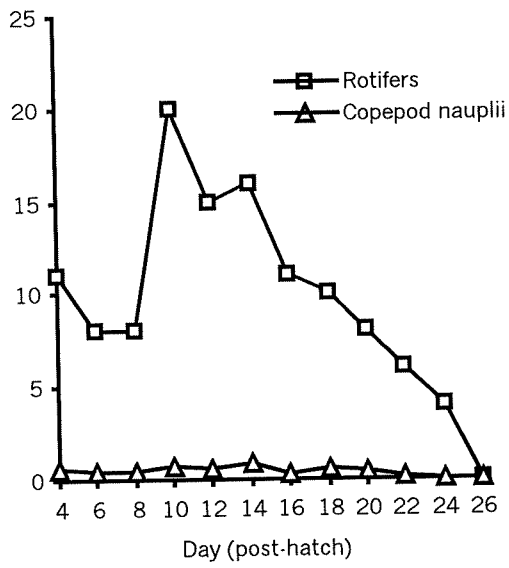

Fig 4-2. Changes in the proportion of different prey in the gut of larval dhufish over time, with separate data for batch DF00-04 (A) and batch DF00-05 (B).

A)



B)

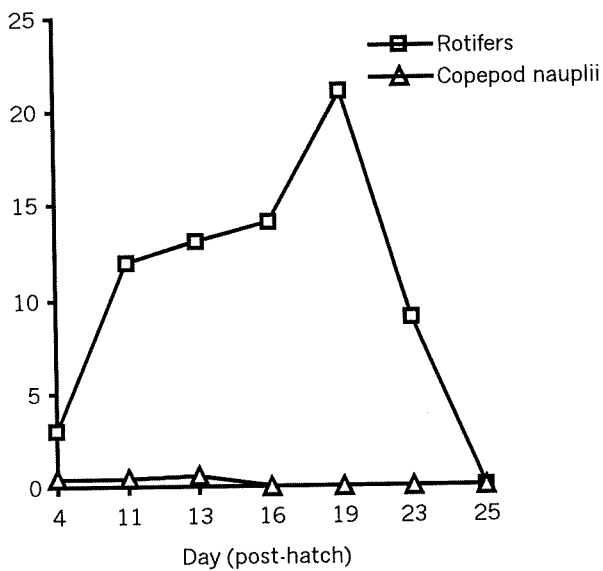

Fig 4-3. Prey densities in greenwater larviculture tanks. Separate data for DF00-04 (A) and DF00-05 (B) are provided.

#### 4.4 Discussion

Dhufish growth and survival in batches DF00-04 and DF00-05 were not as high as expected. Given previous success using copepod nauplii as prey (DF99-00), poor results may be explained by the low initial density of copepod nauplii achieved in the present study. For both batches, adult copepods were stocked into greenwater systems on the same day as the larvae. A previous trial has shown that nauplius densities do not increase until 8 days after stocking with late copepodids and adults. Thus, in the present study, dhufish larvae did not have access to high densities of copepod nauplii at the critical first feeding stage. This contrasts the previous trial (DF99-00) in which copepod nauplii were available to first feeding larvae at a density of 5/ml. It is clear that adult copepods must be stocked into greenwater larviculture systems well before larvae to allow nauplius densities to increase prior to first feeding. Unfortunately, this was not possible in the present work as availability of larvae for trials could not be predicted. In the future, this problem could be overcome by the maintenance of continuous copepod cultures in 5000 l larviculture tanks that are available for immediate larval stocking. Protocols for maintaining these copepod cultures are currently being developed at ADU.

Another difference between the present study and the previous successful trial (DF99-00) was the level of supplementary feeding with T-Iso; 10,000-50,000 cells/ml/day compared to 50,000-100,000 cells/ml/day, respectively. Clearly, T-Iso supplementation was much lower in the present study. T-Iso is a rich source of DHA, the principle essential fatty acid required by marine fish larvae. Thus, in the present study larvae may have received insufficient quantities of DHA from their diet. Furthermore, *Nannochloropsis* is rich in another essential fatty acid, EPA. When *Nannochloropsis* is more abundant than T-Iso (as in the present study), EPA is more abundant in live prey than DHA. This is not desirable for rearing marine larvae that generally require approximately twice the amount of DHA compared to EPA in their diet (Sargent *et al.*, 1999). Thus, in future 5000 l greenwater systems T-Iso supplementation must be increased or *Nannochloropsis* densities decreased in order to increase the DHA:EPA ratio in live prey. Concurrent fatty acid analyses of live prey during these trials will enable optimum densities of *Nannochloropsis* and T-Iso to be established.

In batch DF00-04, survival of 10% was estimated on day 21. From day 21 to 41, survival fell to 3.3%. During this period, up to 43 dead dhufish juvenile were removed daily from the surface or bottom of the tank. This late mortality was not observed in batch DF00-05. The most substantial difference between the two batches during this time was their prey; DF00-04 juveniles were fed almost exclusively on enriched *Artemia* whereas DF00-05 juveniles continued to predate copepodids. The substantial copepodid population available to the latter is likely explained by the higher rate of T-Iso supplementation and/or the lower density of *Nannochloropsis*. Similar nauplius densities in both DF00-04 and DF00-05, despite fewer copepods being added to DF00-05 also suggests higher copepod survival in this tank, perhaps as a result of the algal regime. Dead juveniles from DF00-04 often had their gut completely full of *Artemia* nauplii. It is possible that *Artemia* were a source of bacterial infection or that the choice of enrichment media (Algamac 2000) was inappropriate for dhufish. Substantial mortality in juveniles fed abundant *Artemia* nauplii (enriched with Super Selco®) was not observed in the previous successful trial (DF99-00).

A marked change in behaviour of juvenile dhufish was observed around day 21. Juveniles displayed a tendency to school together, often near substrate such as airstones. This may correspond to a period in the sea when juvenile fish "settle" from pelagic to benthic habitats such as reefs. In a bare culture tank, fish may experience stress at this time when they are unable to find significant shelter. Provision of artificial substrate and/or reduced light intensity may serve to reduce stress at this time.

In greenwater larval tanks that included copepods, it was not possible to measure the density of epibenthic copepodids without major disturbance to the larvae. Hence, prey selection indices that take account of the proportions of each prey item available to larvae could not be calculated. However, raw larval gut content and prey density data indicate some important trends. First feeding dhufish larvae clearly preferred copepod nauplii, further indicating the importance of ensuring an early abundance of copepod nauplii in greenwater systems. High predation rates by larvae on copepod nauplii probably explains the low nauplius densities recorded in the water column. Rotifers appeared to be an important food source for later larvae of batch DF00-04, although this may have resulted from a lack of copepod nauplii and copepodids in this tank at this

time. With more nauplii and copepodids available to DF00-05 fish (as indicated by gut content), fewer rotifers were predated by these larvae. Interestingly, high copepodid predation rates in DF00-05 juveniles did not correspond to a high growth rate in these larvae (Fig 4-1). *Artemia* appeared to replace copepodids as the major prey item for DF00-04 juveniles despite the abundance of copepodids in the tank at this time.

The flow-through greenwater systems were effective in maintaining water quality and turbidity. This system enabled the use of fluorescent light for illumination rather than the usual 400 W metal halide, necessary for maintaining health of algae in static larviculture tanks. The current study did not determine if lowered light intensity was beneficial to dhufish larviculture. A priority for further work is to measure the rate of feeding by larvae at controlled light intensities.

## 5.0 Replication of a previous successful dhufish rearing trial (DF99-00)

### 5.1 Introduction

To date, success of a previous dhufish larviculture experiment using copepods as food (DF99-00) has not been repeated. Given the requirement for dhufish juveniles for next season's grow-out trials, this successful trial will be replicated.

### 5.2 Materials and Methods

This trial was conducted in two 220 l barrels. It was intended that this trial be conducted using techniques similar to those described by Payne *et al.* (in press) that were used successfully to rear batch DF99-00. However, some changes to the original technique were made in this trial.

- *Nannochloropsis* was added once daily rather than pumped continuously into each container
- intensive copepod cultures were not productive at this time hence copepod nauplii were added in much lower numbers

In addition, minimum DO was 56% in this trial, compared to 89% in the previous trial. Both trials made use of bore water, hence the explanation for this difference is not known.

Copepod nauplii were stocked at the same time as larvae (2 days post-hatch) at 3.5/ml and rotifers at 3/ml. Copepod density peaked at 3.5/ml on day 5 and then averaged 1.9/ml from day 5 to day 13. Rotifer density peaked at 12/ml. *Artemia* were added to the barrels on day 17.

### 5.3 Results

Average length of larvae was 5 mm on day 13. On day 22, they were still 5 mm in length. Survival appeared to be high during the initial stages of the trial. However on day 41 average survival was 1.8%.

### 5.4 Discussion

Two factors contributed to poor growth and survival of larvae in this trial. Firstly, low numbers of nauplii were available for feeding to larvae after the initial stocking of 3.5/ml. Secondly, water quality was generally poor in this trial. Clearly, intensive copepod cultures must be made more reliable in the future. Low DO is typical of bore water, hence further larviculture trials should either include pre-treatment of bore water prior to use in larviculture tanks or, preferably, make use of ocean water.

Initial high survival during the period when copepod nauplii were available to larvae gives further evidence of their efficacy as a diet for dhufish larvae. Growth and survival decreased when fewer copepods were available to larvae.

## 6.0 Improvement of intensive copepod culture techniques

### 6.1 Introduction

A copepod culture system has been established at ADU since 1998/1999. To date, production from this intensive system has proved unreliable. During the 1999/2000 dhufish larviculture season, sustained nauplius production was achieved in only one culture. Given that provision of cultured copepod nauplii greatly improves growth and survival in larval dhufish, there is a need to improve reliability of these cultures.

### 6.2 Materials and Methods

The copepod culture system comprised a 1000 l cylindrical-conical fibreglass vessels and a 200 l plastic barrel. Fig. 6-1 illustrates the system and describes techniques for regular nauplius collection. Two 1000 l copepod cultures operate concurrently. Failure of these cultures during 1999/2000 were associated with two forms of contamination;

- copepod cultures were invaded by harpacticoid copepods
- algae used to feed copepod cultures was often contaminated with other organisms, most commonly an unidentified heterotrophic haptophyte.

Harpacticoids that invade *G. imparipes* cultures infest internal surfaces of water pipes and tank throughout the facilities at ADU. Thus, preventing their introduction into *G. imparipes* cultures can be difficult. The establishment of a dedicated copepod culture room at ADU in February 2000 was the first step towards preventing infestation with harpacticoids. This culture room had its own dedicated equipment that was not used in other parts of the facility. Cartridge filters were fitted to all seawater supply lines to prevent introduction of harpacticoids to copepod culture tanks.

Previous intensive copepod cultures that have recorded unreliable production have been operated in full strength seawater (35‰). In these cultures harpacticoids can be removed by rapidly lowering the salinity. *G. imparipes* is an estuarine copepods whereas the harpacticoids that invade *G. imparipes* cultures at ADU are marine. Previous studies have shown that *G. imparipes* can be cultured at lower salinities, hence it was decided to culture *G. imparipes* in seawater diluted to approximately 18‰ (50% seawater:50% carbon filtered tap water). This required the reduced salinity water to be pre-mixed in a reservoir prior to filling copepod cultures.

An unidentified heterotrophic haptophyte is common in algal cultures and in aged greenwater larviculture systems at ADU. The effect of this alga on copepod health was unknown, hence a trial was established to assess this. Replicate containers (150 ml) of adult copepods were fed excess T-Iso or the heterotrophic haptophyte collected from T-Iso cultures. A third groups was left unfed. Copepod survival was recorded daily on these diets.

Contamination of algal cultures by heterotrophic haptophytes was addressed by improving techniques for mass culture of algae used to feed copepod cultures. Previously, 1000 l cultures of T-Iso were maintained outside where they were exposed to wind-borne spray from the ocean. This was the most likely source of contamination. In April 2000, a dedicated room for culturing algae specifically for copepods was established next to the copepod culture room. Two species of algae suitable for culturing copepods were grown in four 1000 l plastic tanks under artificial light in this room. This greatly reduced the incidence of algal culture contamination. In June 2000, algae from these clean cultures was used to establish two semi-continuous copepod cultures in 1000 l tanks.

A further improvement has been made to the 1000 l copepod culture system. Previously, refilling the culture tank from the reservoir required constant attention to prevent overflowing and subsequent loss of copepods in the overflow water. A low voltage float switch in the culture tank now turns off the refill pump via a solenoid switch. This device has proved to be very reliable and has reduced the time required to operate the copepod cultures.

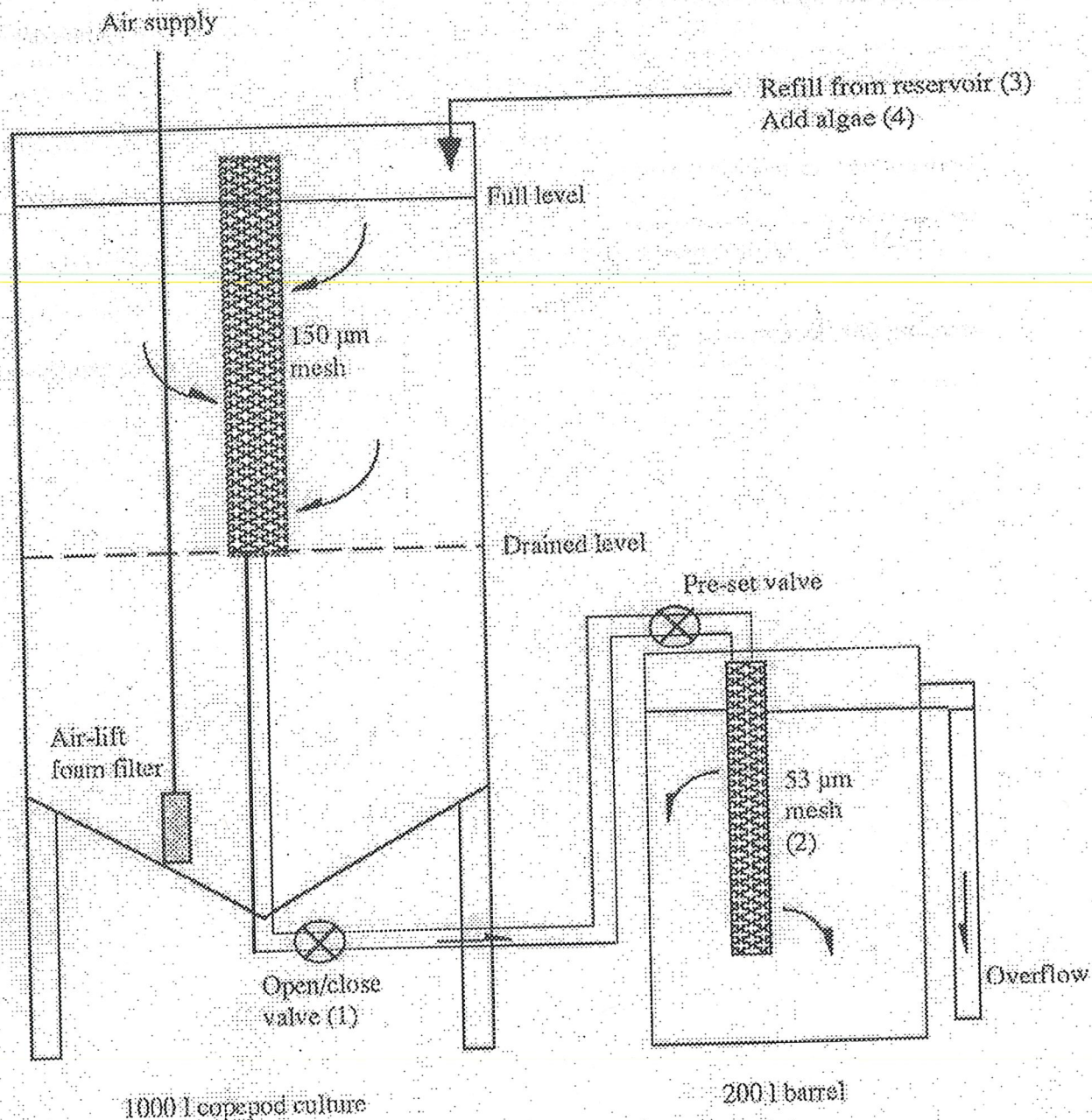

Fig. 6-1. Schematic diagram of a 1000 l copepod culture system. Nauplius collection and water exchange procedures are described as follows;

- (1) Valve opened allowing half the volume of 1000 l culture vessel to drain through 150 µm mesh into submerged 53 µm mesh. Pre-set valve ensures slow drainage (~10 l/min).
- (2) When draining complete, valve closed and nauplii rinsed from 53 µm mesh.
- (3) Culture vessel refilled with diluted seawater from reservoir.
- (4) Copepods fed with algae.



6.3 Results

Table 6-1 shows that production from intensive copepod cultures was greatly increased as a result of improved techniques. Only two copepod cultures were established after the improvements were implemented and these were so successful that they were maintained semi-continuously, without the need for regular cleaning and restocking of cultures.

Table 6-1 Production outputs from three intensive copepod cultures operated in 1000 l tanks at ADU. The first culture was the only successful culture operated during the 1999/2000 dhufish larviculture season prior to establishment of improved techniques. Data from two copepod cultures that incorporate these techniques are provided.

Culture start date	Duration of culture (days)	of Duration of nauplius collection (days)	Daily nauplius collection Mean (range) x10 <sup>3</sup>	Total nauplii x10 <sup>6</sup>
<b>Before improvements</b>				
Mar 00	91	74	122 (20-825)	9.2
<b>After improvements</b>				
June 00	156	121	406 (0-2800)	49.5
June 00	148	121	634 (0-4200)	83.6

Fig 6-2 indicates that the unidentified heterotrophic haptophyte was a poor food for adult *G. imparipes* compared to T-Iso.

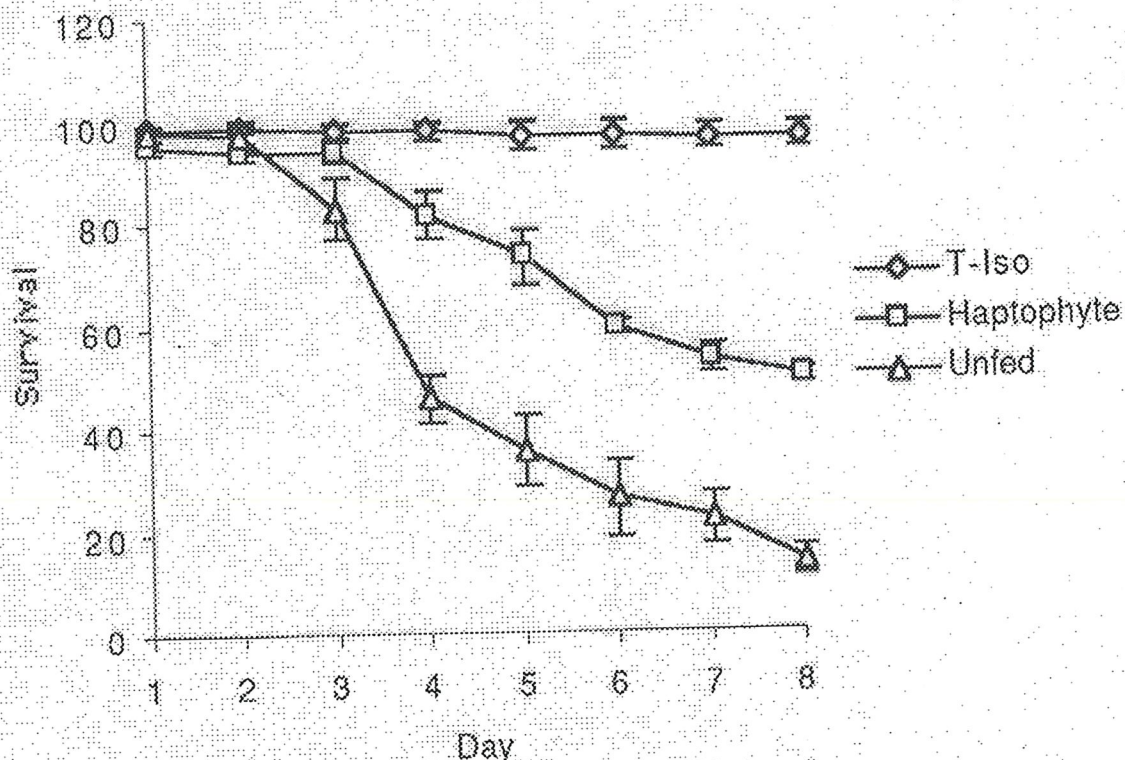

Fig 6-2. Survival of adult *G. imparipes* fed excess diets of T-Iso and a heterotrophic haptophyte collected from 1000 l T-Iso cultures which it had invaded. Data from unfed controls is also included (mean ± sd).

6.4 Discussion

Culturing copepods at lowered salinities in a dedicated room has led to increased nauplius production over a sustained period. Improved algal culture techniques has also likely contributed to this increase. These practises will allow provision of larger numbers of copepod nauplii for future larviculture studies. However, even with these improved techniques, average copepod production from two 1000 l cultures is approximately 1 million/day which enables nauplii to be

stocked into 5000 l larviculture vessels at the low rate of 0.2/ml/day. This emphasises the importance of substantial *in situ* nauplius production from stocked adult copepods in greenwater larviculture systems.

Operation of the present copepod culture system requires minimum labour. Further savings in time and effort may be achieved by reducing labour demands associated with maintenance of large-scale algal cultures. Other successful intensive copepod culture systems have made use of continuous algal bioreactors (Støttrup *et al.*, 1986; Støttrup and Norsker, 1997). These culture systems allow for continuous production of high quality algae with minimum space and labour requirements. With appropriate control systems, algae produced from these bioreactors can be fed automatically to copepod cultures at a specified rate. High initial costs to establish these systems is offset by the reduced labour required to operate them.

Poor survival of *G. imparipes* when fed the unidentified heterotrophic haptophyte may explain why copepod cultures fed algae from cultures contaminated with this haptophyte do not thrive. However, there is increasing evidence that use of heterotrophic algae, particularly dinoflagellates, greatly increases growth and fecundity in cultured copepods (Klein Breteler, 1980; Klein Breteler *et al.*, 1999). Dinoflagellates are currently cultured by the Northern Fisheries Centre (Cairns, Queensland) to boost production from copepod cultures. Intensive *G. imparipes* cultures may similarly benefit from use of a suitable heterotrophic algal species.

## 7.0 Evaluation of a dinoflagellate as food for cultured copepods

### 7.1 Introduction

There is growing evidence that dinoflagellates are an important diet for calanoid copepods. Numerous studies have recorded increased health in calanoid copepods fed specific dinoflagellates. At the Northern Fisheries Centre (Cairns, Queensland), the dinoflagellate *Heterocapsa niei* is used to feed cultures of the calanoid copepod *Acartia* sp. Use of this alga greatly improves production from these cultures. This trial aimed to determine if *Heterocapsa* similarly improved production from intensive cultures of *G. imparipes*.

### 7.2 Materials and Methods

#### 7.2.1 Copepod maturation

The dinoflagellate *Heterocapsa* was obtained from the CSIRO Collection of Living Microalgae (CS-89). This alga was cultured using G media (recipe obtained from CSIRO) in 5 l Pyrex flasks at Curtin University (Perth, Western Australia).

Techniques used to conduct this trial are described fully by Payne and Rippingale (2000). Briefly, nauplii were collected from intensive cultures and screened through 100 µm mesh to provided animals of approximately uniform age class (<24 h old). Nauplii were then evenly distributed between twelve 150 ml plastic containers. Volumes were made up with filtered seawater diluted to 18‰ and maintained at 20±0.5°C. Treatment diets comprised *Heterocapsa* only, T-Iso only and a mixture of both (1:1 by cell numbers). Nauplii were fed daily to excess with the treatment diets. Every third day, 90% of the volume in each container was replaced with clean water.

Copepod maturation was used as an indicator of diet efficacy. At maturity, females carrying their first egg sac were removed individually and counted from containers daily using a stereo microscope and pipette. Daily collection continued until all females had reached maturity. Cumulative proportions of mature females reared on treatment diets were logit transformed and regressed against time. The time taken for 50% of females to reach maturity on each diet was predicted from these regressions and compared using a oneway ANOVA and Tukey's W procedure.

#### 7.2.2 Culture media for *Heterocapsa*

At CSIRO, *Heterocapsa* is cultured using G media, which requires the use of relatively large volumes of soil extract. This is easy to prepare in small volumes for *Heterocapsa* cultures of less than 20 l. However, production of large volumes of soil extract necessary for mass culture of *Heterocapsa* is very inconvenient. Over a 12 month period, the Northern Fisheries Centre produced a strain of *Heterocapsa* that can be grown on standard f/2 media. This strain was unavailable for feeding to copepods during the present study, hence development of a similar strain was investigated. This was achieved by gradually decreasing the proportion of G media and increasing the proportion of f/2 media in successive *Heterocapsa* cultures.

### 7.3 Results

Copepod maturation was significantly fastest ( $P < 0.001$ ) on a diet of *Heterocapsa* only, followed by the mixed diet. Maturation was slowest of a diet of T-Iso only (Fig 7-1).

*Heterocapsa* was first received in Dec 1999. In Oct 2000, a strain that grew successfully on f/2 was produced. The growth of this strain in 100 and 1000 l volumes is presently (Dec 2000) being investigated at ADU.

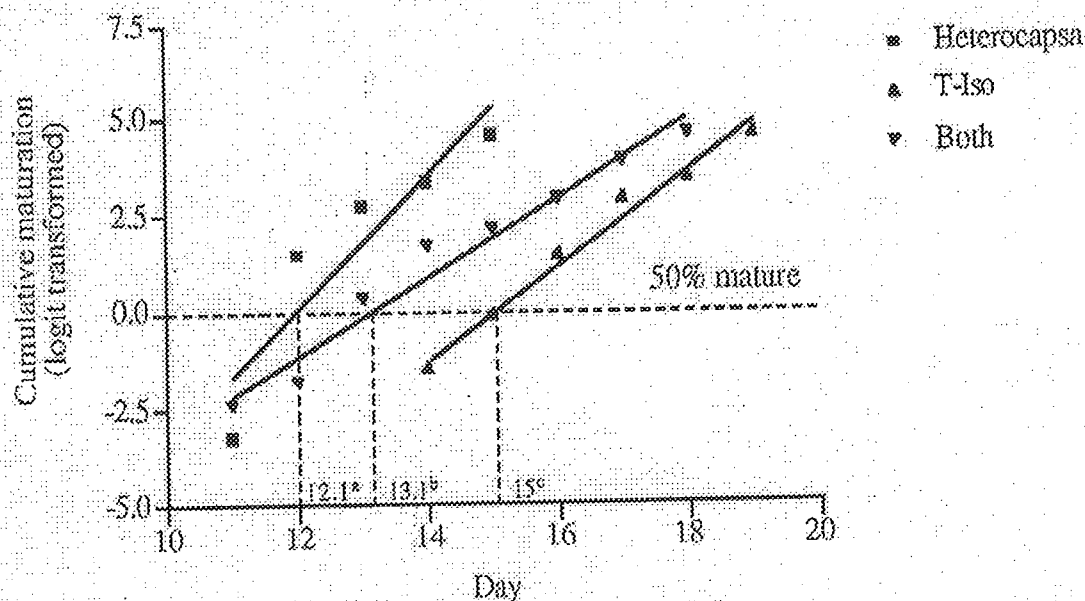

Fig 7-1. Cumulative maturation (logit transformed) over time of female copepods fed *Heterocapsa*, T-Iso and a combination of both at 20°C. Dotted lines represent time (x axis) taken for 50% cumulative maturation (y axis). Days with different superscripts are significantly different ( $P < 0.05$ ).

#### 7.4 Discussion

A previous study has determined that of a range of experimental diets, T-Iso was most efficacious for *G. imparipes* cultures (Payne and Ripplingale, 2000). Hence, the use of this alga for intensive cultures and in larviculture systems that include *G. imparipes*. Results of this study suggest that *Heterocapsa* may be an even better diet for *G. imparipes* than T-Iso. This is consistent with other studies on the use of dinoflagellates for culturing calanoid copepods. However, further studies on the use of *Heterocapsa* for feeding *G. imparipes* is warranted. *Heterocapsa* fed *G. imparipes* must be assessed for fecundity and nutritional content for larval fish. Surprisingly, copepods fed the mixed diet in the present study were slower to mature than those fed *Heterocapsa* only. Combined diets are often preferred over monodiets as they are likely to provide a more balanced diet that supports increased fecundity. This may be the case in the present trial and also requires further attention.

The copepod maturation trial was conducted using *Heterocapsa* cultured on G media. This trial should now be repeated using the *Heterocapsa* strain cultured on f/2. If this strain of *Heterocapsa* can be grown reliably in large volumes, and it remains a beneficial diet when cultured on f/2, these developments could greatly improve the prospects of utilising *G. imparipes* for commercial dhufish larviculture.

## Conclusions and Recommendations

The project did not fulfil its primary objective, which was to successfully incorporate copepods into commercial-scale larviculture practises for dhufish. However, significant progress was made in this direction, as well as in improving the reliability and magnitude of nauplius production from intensive copepod cultures. The following conclusions and recommendations will assist further development of techniques for successful utilisation of cultured copepods for rearing dhufish larvae.

1. Nauplius production from adult copepods stocked between 100-200/l in *Nannochloropsis* greenwater systems is sufficient to support high growth and survival in larval dhufish.
2. Adult copepods must be maintained in greenwater systems at least eight days prior to larval stocking to ensure high nauplius densities at first feeding. Alternatively, continuous copepod cultures (with regulated densities of nauplii) could be maintained in 5000 l tanks ready for immediate stocking with larvae.
3. Copepod-greenwater systems should be provided supplementary feeding with T-Iso at minimum rates of  $5-10 \times 10^4$  cells/ml/day to maximise *in situ* copepod production.
4. Further work is required to determine the optimum density of *Nannochloropsis* that should be maintained in these systems. Provisionally, a relatively low Secchi depth of 80-100 cm should be maintained. This may provide for increased copepod fecundity and increase the DHA:EPA ratio in dhufish prey.
5. Later dhufish larvae readily predated rotifers, hence combined copepod/rotifer diets should be used. Copepod nauplii must predominate during the first few days of larval feeding.
6. If copepodid populations permit, feeding with *Artemia* should be delayed to encourage juvenile dhufish to predate copepodids. Alternative enrichment techniques for these *Artemia* should also be examined.
7. Further improvements to intensive copepod cultures should focus on their algal diet, particularly the use of bioreactors for growing high quality algae, and *Heterocapsa* grown on f/2 as food.

**References**

- Klein Breteler, W.C.M., 1980. Continuous breeding of marine pelagic copepods in the presence of heterotrophic dinoflagellates. *Marine Ecology Progress Series* 2, 229-233.
- Klein Breteler, W.C.M., Schogt, N., Bass, M., Schouten, S., Kraay, G.W., 1999. Trophic upgrading of food quality by protozoans enhancing copepod growth: role of essential lipids. *Marine Biology* 135, 191-198.
- Naas, K.E., Næss, T., Harboe, T., 1992. Enhanced first feeding of Halibut larvae (*Hippoglossus hippoglossus* L.) in green water. *Aquaculture* 105, 143-156.
- Payne, M.F., Ripplingale, R.J., 2000. Evaluation of diets for culture of the calanoid copepod *Gladioferens imparipes*. *Aquaculture* 187, 85-96.
- Payne, M.F., Ripplingale, R.J., Cleary, J.J., in press. Cultured copepods as food for West Australian dhufish (*Glaucosoma hebraicum*) and pink snapper (*Pagrus auratus*) larvae. *Aquaculture*.
- Sargent, J., McEvoy, L., Estevez, A., G., B., Bell, M., Henderson, J., Tocher, D., 1999. Lipid nutrition of marine fish during early development: current status and future directions. *Aquaculture*. 179, 217-229.
- Schipp, G.R., Bosmans, J.M.P., Marshall, A.J., 1999. A method for hatchery culture of tropical calanoid copepods, *Acartia* spp. *Aquaculture*. 174, 81-88.
- Støttrup, J.G., Norsker, N.H., 1997. Production and use of copepods in marine fish larviculture. *Aquaculture*. 155, 231-248.
- Støttrup, J.G., Richardson, K., Kirkegaard, E., Pihl, N.J., 1986. The cultivation of *Acartia tonsa* Dana for use as a live food source for marine fish larvae. *Aquaculture* 52, 87-96.

## Appendix P Developing a weaning technique for dhufish larvae

### 1. Introduction

Although larval rearing of WA dhufish has been moderately successful (up to 37% survival to metamorphosis; Payne *et al.*, 2000), weaning has proved to be difficult. Due to the highly selective feeding nature of juvenile dhufish and the limited number of fish available for trials, preliminary attempts to wean the larvae onto an artificial diet were unsuccessful. It was observed that ingestion of the commercially available weaning diet was low, resulting in high mortality during weaning. As pellet attractiveness is one of the key requirements for a successful weaning diet, in the current study a range of techniques for improving pellet attractiveness were compared in 2 separate studies.

The first experiment compared a commercial diet (Nippai ML) with a microbound diet (MBD; prepared by blending fresh fish flesh, enriched artemia meta-nauplii and the commercial diet) and live-feed diet (newly hatched snapper larvae, *Pagrus auratus*). A second experiment compared preparation techniques of the fresh MBD (fridge-dried vs oven-dried MBD) and also investigated a simple way of potentially improving the attractiveness of the commercially available diet by coating it with a fish emulsion. These were compared to the commercial diet (control). The performance of each diet was assessed in terms of growth, survival and observations of the interest of the fish in the pellet (ie number of strikes at pellet per 2 minutes).

### Methods

#### *Source of larvae*

#### Experiment 1

Larvae were obtained from stripping eggs and sperm from hormone treated captive dhufish. Larvae were reared in a flow-through system in a series of 140L cylindrical tanks with blue walls and white bottoms at an initial stocking density of 6 larvae.L<sup>-1</sup>. Rearing is described in Payne *et al.* (2000). Larvae were fed on cultured copepod nauplii reared on *T-Iso* and rotifers enriched with Super Selco®. At 6mm in length, larvae were weaned onto artemia metanauplii enriched on Super Selco® and were then fed 4 times daily to satiety, and also readily consumed broodstock calanoid copepods resident in the tank.

#### Experiment 2

Eggs were obtained as for experiment 1. Larvae were reared in a semi-intensive system modified from Partridge *et al.* (1998) in a 5,000 litre cylindro-conical tank. Larvae fed on rotifers

(self-maintaining population in tank feeding on microalgae) and natural blooms of harpacticoid copepods. When larvae measured 5.7 mm, *Artemia metanauplii* enriched with Super Selco® were fed 4 times daily to satiety.

### *Experimental system*

Each dietary treatment was investigated in triplicate in 160-L blue cylindrical tanks with white bases. Each tank was fitted with 800µm outlet screens and supplied with seawater (filtered to 1µm) at 1 litre.minute<sup>-1</sup> and aeration. Temperature and dissolved oxygen were measured daily and adjustments made to maintain similar conditions between tanks. Each tank was vacuumed as required (up to 2 times daily). Larvae were stocked to the experimental system by slowly draining the larviculture tank and, using a beaker to gently scoop up the larvae and transfer them to the experimental tanks. Larvae continued to be fed solely on enriched *Artemia* nauplii until experimental Day 2 when the weaning diets were introduced.

### Experiment 1

Larvae were harvested from their tanks on Day 28 post-hatch. Ninety-nine fish (mean length 13.17 ± 0.36 mm, n = 10) were stocked into each of 9 x 160 litre cylindrical tanks (described above). Tanks were allocated randomly in triplicate to one of three treatments of different weaning diets: live feed, commercial pellet (ML) or fridge-dried micro bound diet (fridge-dried MBD).

### Experiment 2

When larvae exceeded 12mm (Day 45 post-hatch), seventy-four dhufish larvae were stocked into each of twelve tanks described above. Tanks were randomly allocated in triplicate to one of four treatments of different weaning diets: commercial pellet, commercial pellet sprayed with fish emulsion (Spray ML), fridge-dried microbound diet (fridge-dried MBD) and oven-dried microbound diet (Oven-dried MBD).

### *Weaning strategy*

The basic weaning strategy for experiments 1 and 2 was to reduce the number of artemia feeds per day from four (Days 1-9) to three (Days 10-30) and then to gradually reduce the amount of artemia per feed. The amount of artemia per feed was initially 30,000 (Days 1-11). Beginning on Day 12, this was gradually reduced to zero by Day 32. Concurrent to reducing the artemia feeding regime, the number of feeds of the alternate diet was increased from four (Days 3-10) to nine (Days 11-18). From Day 19, in Experiment 1 the alternate diet was presented 19 times per day, while in Experiment 2 for logistical reasons, it was presented 9 times only. For pelletised weaning diets, the size of the pellet was increased gradually: 200-400 µm (Days 3-13); 300-600



µm (14-19); 500-800 µm (Days 20-30); 700-1100 µm (Days 31-43). At each feed, the weaning diets were offered *ad libitum* before the artemia were offered. For pelletised diets, the amount of diet fed was the same among treatments (by volume).

### Diets

#### Live feed

Fertilised snapper eggs were collected from the overflow of a tank containing naturally spawning snapper. These were hatched and fed to the dhufish on either the day of hatch or Day 1 post-hatch. The number of larvae were estimated volumetrically. The number of snapper larvae per feed was increased throughout the experiment: 4 x 500 larvae (Day 3 - 10); 9 x 600 larvae (Day 11-12); 9 x 1000 (Day 13-14); and 9 x 1500 (Day 15-18); and 19 x 1500 (Day 19-43).

#### Commercial diet (ML)

Nippai ML was used with a size range increasing from 300µm on Day 3 to 1000µm on Day 31 according to the schedule above.

#### Micro-bound diets (fridge-dried and oven-dried)

Minced flesh (30% mussel meat, 20% mulies, 20% whiting, 20% prawns and 10% squid), artemia and Nippai ML were blended into a homogenous paste. Small volumes of water added as required to achieve a thick paste. The diet mixture was bound with gelatin at 7.5% by wet weight as follows. Gelatin was dissolved in hot water and then cooled to 40°C. It was then added to the diet mixture and thoroughly mixed. The diet was cast onto trays to a depth of approximately 300 µm. The trays were placed in the fridge at 14°C for 24h (fridge-dried MBD) or in oven at 50°C until dry (oven-dried MBD). Once the diet is dried it was chopped and sieved to the required size.

At the start of the wean the MBD diet (oven-dried and fridge-dried) contained a low proportion of ML (20%) and a high proportion of minced flesh (70%). During the course of the wean, the proportion of Nippai ML increased gradually to 100% while the concentration of flesh decreased to 0 % (according to Table A24). The proportion of artemia remained at 10% throughout the wean, until the proportion of Nippai reached 90%, when it reduced to 2% then 0%.

#### Spray-coated ML

This diet was prepared by spraying ML pellet with homogenised mulies prior to feeding. Spraying occurred each morning, prior to the first feed and the coated pellet was stored in an airtight container in the fridge for the remainder of the day. Spraying continued until Day 40 of the trial, after which straight ML was used.

**Table A24: Composition of microbound diet used in Experiment 1 and 2.**

Days of Trial	Nippai ML (%)	Minced flesh* (%)	Enriched <i>Artemia</i> (%)
3-13	20	70	10
14-17	30	60	10
16-20	40	50	10
19-25	50	40	10
24-26	60	30	10
27-29	70	20	10
27-32	80	10	10
32-37	90	5	2
35-40	100	0	0
39-43	ML only	0	0

\* mussel meat 30%, oily fish fillets 20%, lean fish fillets 20% prawn meat 20%, squid meat 10%.

#### *Data collection*

*Interest in weaning diet:* Observations on the larvae's response to the alternate food source were made during the first feed on each day. During this feed, two observers observed each tank for 2 minutes immediately follow the addition of the artificial diet. A number of fish observed striking pellets were counted and recorded.

*Growth:* A random sample of 10 fish were weighed and measured (SL) on Day 0 (SL only), 20 and 45. The fish in each tank were lightly anaesthetised (40 ppm benzocaine) and 10 fish from each tank were caught individually in fine gauze dip-net, weighed, measured and recovered. The remainder of the fish in each tank were removed and placed into recovery bucket while the tank was refilled.

*Survival:* Mortalities in each tank were removed and recorded daily.

#### *Statistics*

Survival on Day 45 was compared by 1 way ANOVA for each experiment. Weight was compared by 2 way ANOVA for each experiment. Comparisons of means were conducted by Tukey Kramer HSD.  $\alpha=0.05$ .

**Results**

*Experiment 1*

Overall survival for fridge-dried MBD and live feed treatments were significantly greater than for the ML treatment ( $P < 0.05$ ; Fig A48a). Mortalities began on day 18 in both the pelletised treatments. Mortalities in the live-feed treatment first occurred slightly later at day 20. The amount of artemia being fed at this stage was less than 1000 nauplii per day, and the number of feeds of the alternate diet increased from 9 to 19. Mortalities had virtually ceased by Day 25.

Fish in all treatments grew significantly between day 20 and 35, with wet weight increasing from approximately 0.1g at day 20 to between 0.6 and 1 g by day 35 ( $P < 0.01$ ; Fig A49a). At day 20 there was no significant difference in wet weight between treatments, however, by day 35 fish in the fridge-dried and live-feed treatments were significantly heavier than the ML treatment ( $P < 0.01$ ). A similar pattern was found for SL ( $P < 0.01$ ; data not shown).

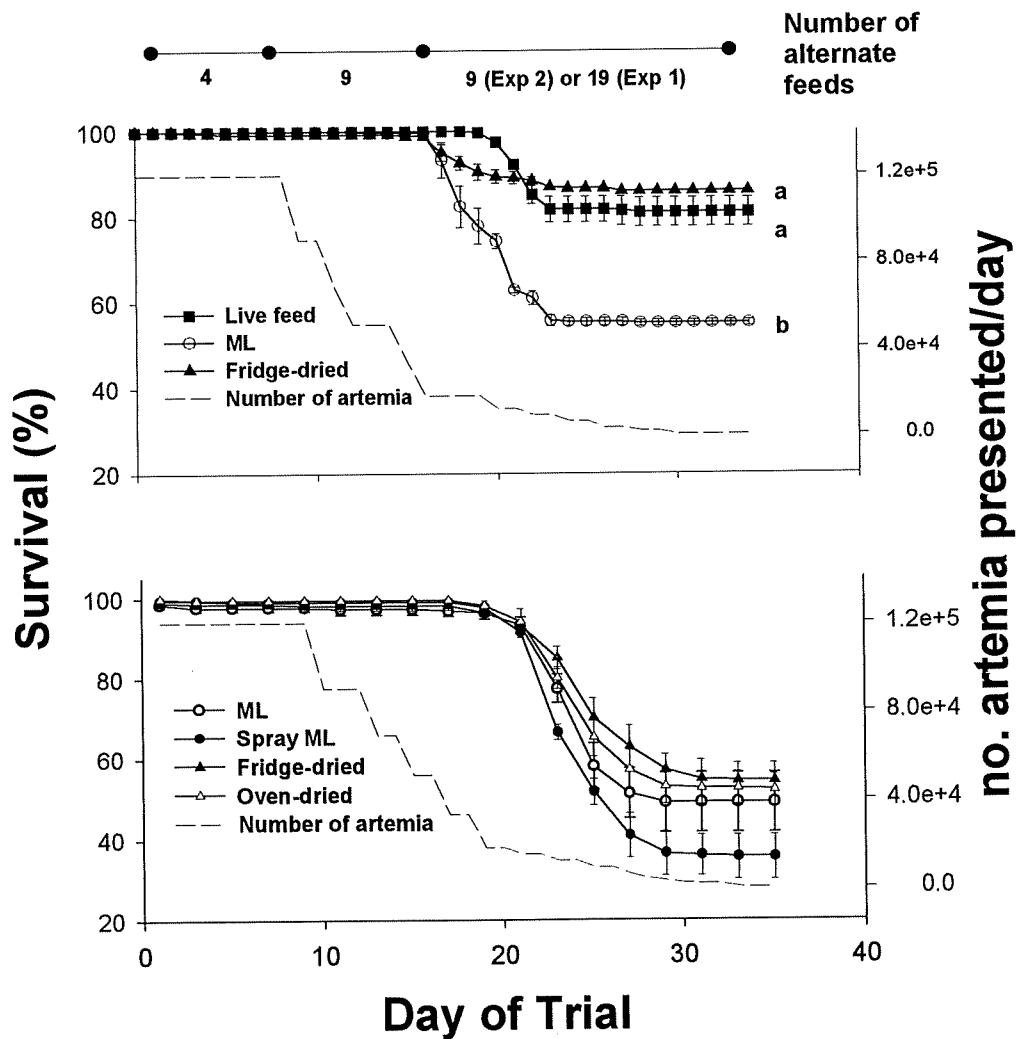

**Figure A48: Survival of dhufish larvae during weaning experiments 1 and 2. Superscripts indicate significantly different Tukey-Kramer HSD groupings at Day 35 ( $P < 0.05$ )**

Strike rate was difficult to assess for the live-feed group because the snapper larvae were too small to be seen clearly. In addition the feeding response to the live feed was usually too vigorous to count with any degree of accuracy. Consequently the variation in counts was high and likely to be meaningless. Therefore this data is not presented here. Striking at the fridge-dried MBD began on day 14 and striking at the ML occurred a day later (Day 15; Fig A50a). The number of artemia being presented on day 14 and 15 was approximately 40,000 artemia per day. Following the first strike, strike rates rapidly increased in both treatments, however, striking on the fridge-dried MBD was higher than on ML.

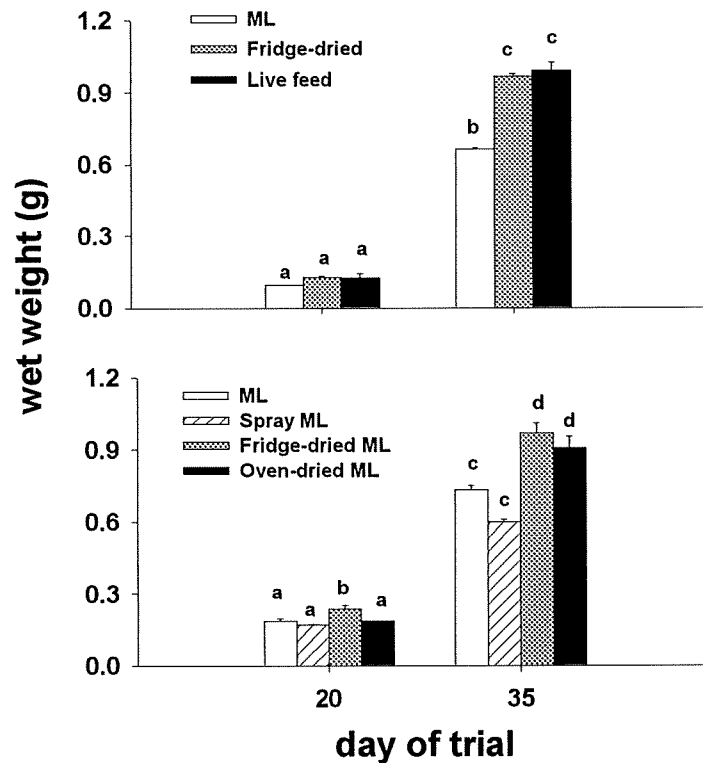

**Figure A49: Wet weight of dhufish larvae at 20 and 35 days during weaning experiments 1 and 2. Superscripts indicate significantly different Tukey-Kramer HSD groupings ( $P < 0.05$ )**

### Experiment 2

Although there was a small number of mortalities in all treatments prior to Day 18, the majority of mortalities were experienced after this time (Fig A48b). The concentration of artemia at this time was less than 10,000 per day. There was no significance in survival at day 35 between the four treatments (due to large standard errors;  $P > 0.05$ ), however, in the spray ML treatment survival was approximately 70% of the other three treatments. Mortalities had virtually ceased in all treatments by day 31.

Larvae in all treatments grew significantly between day 20 and 35 ( $P < 0.05$ ), with wet weight increasing significantly from approximately 0.15 at day 20 to 0.6 – 1 by day 35 (Fig A49b). At day 20 wet weight in fish in the fridge-dried MBD treatment was significantly greater than the other three groups. By day 35, wet weight of the ML and spray ML groups were similar to each other but significantly less than both the fridge- and oven-dried groups. A similar pattern was found for SL (data not shown).

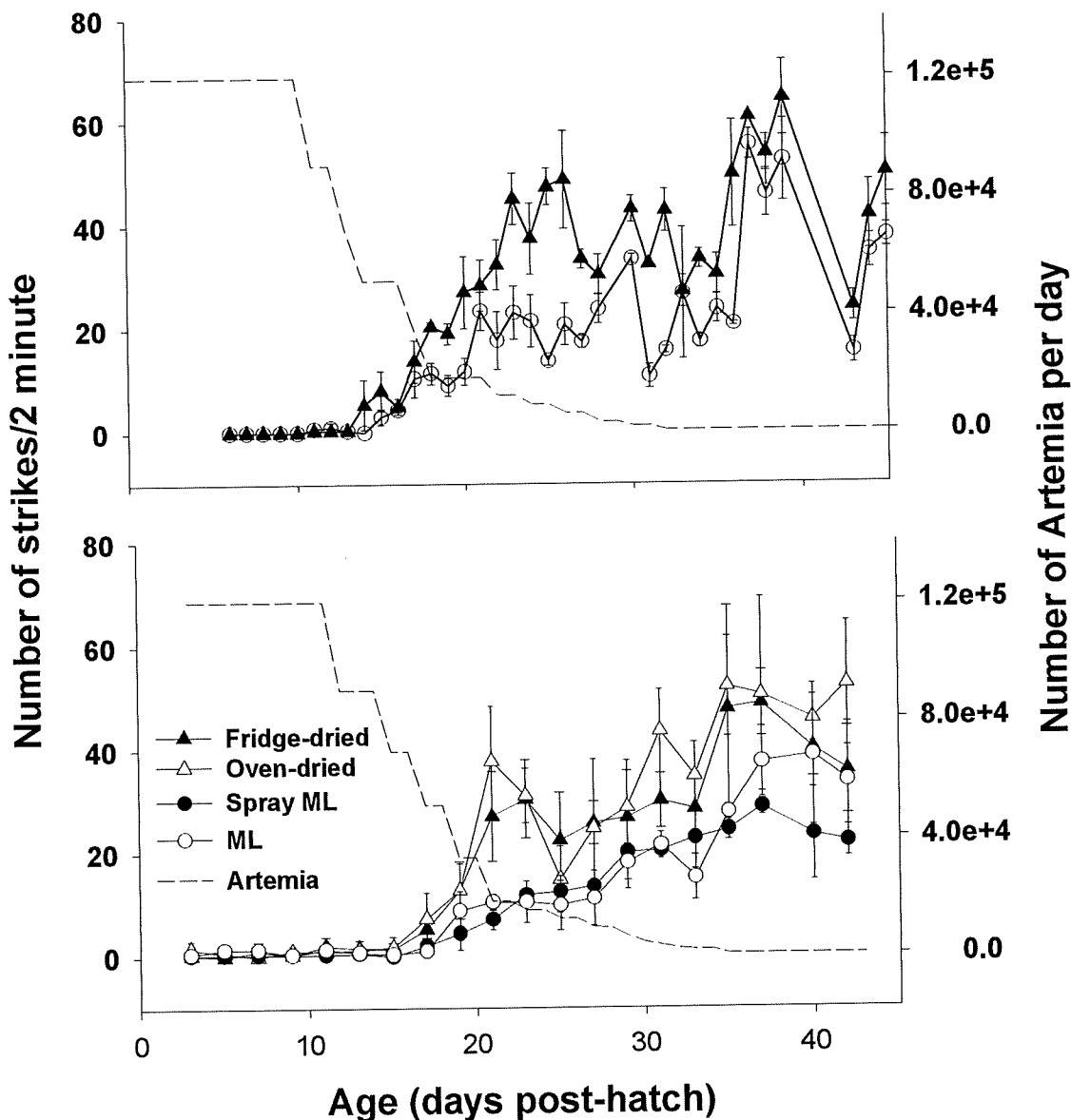

Figure A50: Strike rate of dhufish larvae on various trial weaning diets.

Although some striking at pellets was observed prior to day 15, strike rates began to increase dramatically after Day 15 in all four groups, when the number of artemia presented was approximately 50,000 nauplii per day (Fig A48). Strike rates in oven and fridge-dried groups appeared to increase more rapidly than both spray ML and ML, although again, statistical analysis was hampered by large variation.

## Discussion

Survival in the live feed treatment was similar to the fridge-dried MBD treatment. This was unexpected, particularly as the high strike rates observed in the live feed treatment (data not shown) indicated that the fish were accepting the snapper larvae. Therefore it is possible that the dhufish in this treatment were underfed and the lower than expected survival was due to limitations in food availability not acceptability.

ML was significantly less effective than fridge-dried MBD. This was demonstrated by survival rates and weight at 35 days. Until Day 17, mean strike rate for fridge-dried MBD was always higher than ML suggesting that the difference in survival was due to improved acceptability rather than nutrition advantages.

In contrast to Experiment 1, in Experiment 2, survival of ML fed fish was no different to fridge-dried (or oven dried) MBD. Survival of ML fed fish was approximately 50% in both Experiment 1 and Experiment 2. Survival of fridge-dried MBD fed fish in Experiment 2, however, was approximately half that for Experiment 1. Despite the lack of difference in survival between ML and MBD treatments in Experiment 2, growth was significantly greater in the MBD than ML treatments. Furthermore mean strike rate for ML was generally less than for MBD, indicating that MBD still had positive effect on the acceptance of the pellet. The reason for the lack of difference in survival of larvae fed ML and MBD in Experiment 2 is unknown, however it may be related to the number of times a day the weaning diet was presented. In experiment 1, the weaning diet was presented a maximum of 19 times per day. In experiment 2, due to logistical constraints, the weaning diet in Experiment 2 was only presented 9 times per day. Dhufish are slow, cautious, non-aggressive feeders. It may be that the optimum weaning technique requires constant exposure to the weaning diet. The availability of food in Experiment 2 appears to have compromised the wean. There was no difference in fridge-dried MBD and oven-dried MBD in experiment 2. Since oven-dried MBD is easier to prepare than fridge-dried MBD, oven-dried MBD is selected as the MBD of choice.

Spray ML appears to be the poorest of all treatments as indicated by survival, growth and strike-rate data. The reason for this apparent poor performance of Spray ML is probably largely due to the way the pellet behaved in the water column. The Spray ML pellet was heavier than all the other pellets trialed and so sank to the bottom quickly and did not float in the water column. This may have had a dual effect of reducing the time in which the fish had to strike and also affecting the visual stimuli.

Therefore the use of a microbound diet is a suitable method for weaning dhufish. It is, however, extremely labour intensive. Therefore, a simpler technique must be sort. The wean used in this study was very slow and was conducted on fully metamorphosed fish. Ideally the wean needs to be more rapid and the larvae need to be weaned a younger age.

### References

Payne, M., Rippingale, R.J. and Cleary, J.J (2000). Cultured copepods as food for West Australian dhufish (*Glaucosoma hebraicum*) and pink snapper (*Pagrus auratus*) larvae. Aquaculture in press

**Appendix Q      *Evaluation of feed ingredient utilisation and native tissue composition as a precursor to diet development for the West Australian Dhufish (*Glaucosoma hebraicum*).***

Brett Glencross, John Curnow, Anthony Aris and Jennifer Cleary

**Abstract**

The West Australian Dhufish is seen as a potential high-value, endemic species suitable for marine aquaculture in Western Australia. Recent progress with artificial propagation of the species has encouraged further development of grow-out technology, including the development of grow-out diets for the species. To determine the nutritional value of key feed ingredients the digestibility of nine different ingredients were examined. The influence of ingredient inclusion level and the assumption of digestible additivity were also examined. The digestibility of the dry matter of the various meals was highly variable. Protein digestibilities were significantly higher than the dry matter digestibilities for each ingredient. Energy digestibilities were similar to the protein digestibilities for almost all ingredients, except those with high levels of carbohydrates. Dry matter, protein and energy digestibilities were highest for wheat gluten. Protein digestibilities were also high for blood meal, vitamin free casein and high quality fish meal. The native amino and fatty acid compositions of the flesh were also examined to estimate potential essential nutrient requirements. Amino acid composition of the flesh of dhufish was not significantly different to that observed for other species. The native fatty acid composition though was significantly higher in arachidonic (20:4n-6) and docosahexaenoic (22:6n-3) acids, and lower in eicosapentaenoic (20:5n-3) acid than that typically observed in standard commercial fish oils. These nutrient data suggest that standard protein resources, provided digestible limits are observed, will suffice for this species. However, use of fish oil as the only lipid resource may not be sufficient to fully satisfy potential essential fatty acid requirements. Based on the determined digestible protein and energy characteristics of the examined ingredients, and utilising the knowledge gained from the estimated essential nutrient requirements, detailed examination of this species dietary protein and energy requirements is identified as the next required phase of diet development for this species.



## Introduction

The West Australian Dhufish is seen as a potential high-value, endemic species suitable for marine aquaculture in Western Australia (Pironet *et al.*, 1999). The species naturally occurs from the Recherche archipelago (S 34° 00', E 122° 00') to Shark Bay (S 26° 00', E 113° 00') in Western Australian coastal waters (Potter and Hesp, 1999). Fishery based data indicates that the fish has a comparatively fast growth rate and has a high current market value (Potter and Hesp, 1999). Anatomically, the fish has characteristics typical of an infrequently feeding carnivore, possessing a large gaping mouth, a relatively large muscular stomach and short gastro-intestinal tract (Halver, 1989).

Development of an effective grow-out diet is seen as one of the key steps in establishing a viable aquaculture industry (Tacon, 1990). Therefore, to expedite diet development for this species it may be prudent to base the requirements for a basal diet on one similar to that required for other carnivorous species such as salmonids and seabass (NRC, 1993).

Effective development of diets for a new potential aquaculture species, such as the dhufish, requires knowledge of the nutrient and energy contributions from various key ingredients used in diet manufacture (Aksnes *et al.*, 1996; Sugiura *et al.*, 1998; Allan *et al.*, 1999). Of particular importance is the identification of the relative level of protein and energy contributions made by each of the ingredients to the diet. Details of these contributions from each ingredient will assist in the next phase of diet development, which is to determine the animal's dietary protein and energy requirements. Consequently this determination of ingredient nutritional value is pivotal to many of the remaining phases of nutritional work required during diet development for a new species (van Barneveld, 1999).

This manuscript reports the examination of the relative digestible dry matter (DDM), digestible protein (DP) and digestible energy (DE) contributions from nine key ingredients. Two further diets examine the complimentary additivity of apparent digestibility values from mixes of several of the key ingredients examined. Also examined is the native amino and fatty acid composition of flesh from wild caught *G. hebraicum*. An assessment of the relative basis of indispensable amino acids (IAA) is made to pre-empt the potential IAA dietary requirements. All these parameters are discussed in context with further development of diets for this species.

## Methods

### *Diet development*

A basal diet was formulated and prepared to include approximately 500 g kg<sup>-1</sup> protein, 150 g kg<sup>-1</sup> fat and an inert marker (chromic oxide at 4 g kg<sup>-1</sup>) (Table A25). A basal mash (fishmeal, wheat flour, wheat gluten and fish oil components of the basal diet) was prepared and thoroughly

mixed, forming the basis for all experimental diets in this study. A range of commonly used feed ingredients was obtained from commercial feed companies (Table A26). The ingredient of study for each test diet was sieved to < 500 µm particle size and added to a sub-sample of the basal mash, at a projected final inclusion level of 200 g kg<sup>-1</sup>. The vitamin pre-mix and marker were added individually to each diet before further mixing (See Table A25). Some ingredients (meat meal, blood meal, and ingredients included in tandem in complementary additivity studies) were added only at 100 g kg<sup>-1</sup>. Diets were processed by addition of water (about 50% of mash dry weight) to the mash whilst mixing to form a dough, which was subsequently screw pressed using a pasta maker through a 3 mm Ø die. The resultant moist pellets were then steamed for 4 minutes and oven dried at 80°C for approximately 3 h. The basal diet was prepared in a similar manner, but without the addition of any test ingredient. Composition and source of all of the ingredients used is presented in Table A26.

### *Fish handling*

Hatchery reared juvenile dhufish were obtained from the Aquaculture Development Unit of the South Metropolitan TAFE. The fish were reared from wild-caught broodstock that had been previously acclimated and treated with LHRHa to stimulate ovulation. The larvae and juveniles were reared according to Chapter 6 and 7, this volume.

Eighteen 170 L cylindro-conical settlement-tanks were stocked with 16 to 20 juvenile (7 month, ~ 15 g) Numbers varied depending on experimental block and availability of fish. Treatments were randomly assigned in triplicate to the settlement-tank array. The transferred fish were allowed to acclimate to the settlement-tanks and an allocated dietary treatment for a week before faecal collection commenced. Mortalities were not replaced. Faecal collection was not performed on tanks where a mortality occurred within the preceding 24 h or where feed particles were observed in the settlement tube. Faeces were collected according to the methods described by Allan *et al.* (1999).

Following acclimation the fish were fed to apparent satiety once daily at about 15:00 hrs (3 PM). Uneaten feed was removed from the collection tube of each settlement-tank following feeding and the feed intake recorded. The cleared collection tube was packed in an iced container and faeces collected by settlement overnight. The settled faeces were collected each morning (08:00) and pooled within tanks and across days (Allan *et al.*, 1999). Faeces were collected over a minimum of six days, and kept frozen (-20°C) pending analysis.

Three blocks (about 14 to 20 days duration) of independent studies were conducted over a seven week period. In each experimental block, one of the six treatments was the basal diet.

*Chemical and digestibility analysis*

Diet and faecal samples were analysed for dry matter, chromium, protein and gross energy content. Dry matter was calculated by gravimetric analysis following oven drying at 100°C for 24 h. Chromic oxide levels were determined by atomic absorption spectrometry based on the method described by Hillebrand *et al.* (1953). Protein levels were calculated from the determination of total nitrogen by Kjeldhal analysis, based on N x 6.25. Both of these determinations were conducted according to the methods specified by the AOAC (1984). Gross energy was calculated based on the energetic values of crude protein (23.6 MJ kg<sup>-1</sup>), fat (39.5 MJ kg<sup>-1</sup>) and carbohydrate (17.1 MJ kg<sup>-1</sup>) levels. Differences in the ratios of the dry matter, protein or gross energy to chrome, in the feed and faeces in each treatment were calculated to determine the apparent digestibility coefficient (ADC<sub>diet</sub>) each of the nutritional parameters examined in each diet based on the following formula (Aksnes *et al.*, 1996):

$$ADC_{diet} = 1 - \left( \frac{Cr_{diet} \times Parameter_{feces}}{Cr_{feces} \times Parameter_{diet}} \right)$$

Where Cr<sub>diet</sub> and Cr<sub>feces</sub> represent the chromium content of the diet and faeces respectively, and Parameter<sub>diet</sub> and Parameter<sub>feces</sub> represent the nutritional parameter of concern (dry matter, protein or energy) content of the diet and feces respectively. Digestibility values for specific ingredients (ADC<sub>ingredient</sub>) in each of the diets were based on the following formula (Aksnes *et al.*, 1996):

$$ADC_{ingredient} = \frac{1}{n} \left( \frac{TD Cr_{diet} \times TD Parameter_{feces}}{TD Cr_{feces} \times TD Parameter_{diet}} \right) - \frac{1-n}{n} \left( \frac{BD Cr_{diet} \times BD Parameter_{feces}}{BD Cr_{feces} \times BD Parameter_{diet}} \right)$$

Where TD Cr<sub>diet</sub> and TD Cr<sub>feces</sub> represent the chromium content of the diet and feces of the test diet respectively, and similarly TD Parameter<sub>diet</sub> and TD Parameter<sub>feces</sub> represent the nutritional parameter of concern (dry matter, protein or energy) content of the diet and feces of the test diet respectively. Accordingly the BD notation precedes all specifications concerned with the basal diet.

Samples of wild fish tissue (muscle) were analysed for both their amino acid and fatty acid compositions. The amino acid composition of the flesh was determined with high performance liquid chromatography, using ion-exchange column separation and UV/Vis detection of derivatised amino acids. Fatty acid composition was determined using gas chromatography following trans-esterification of total lipids extracted from the muscle tissue by the method of Folch *et al.* (1957). Both methods were in accordance with AOAC (1984) specifications.

### *Statistical analysis*

All figures are mean  $\pm$  SEM unless otherwise specified. Effects of ingredient inclusion on digestibility of dry matter, protein and gross energy were examined by ANOVA. Levels of significance were determined using Tukeys HSD test, with critical limits being set at  $P < 0.05$ .

### **Results**

Dry matter digestibilities for all test ingredients varied considerably (Table A27). Highest dry matter digestibility was observed with wheat gluten (0.999) with essentially 100% digestibility. Lowest dry matter digestibility was observed with wheat flour (0.351). Dry matter digestibilities generally showed higher levels of variance in their determination than both protein and energy digestibilities.

Protein digestibilities also varied considerably between ingredients (Table A27). Highest protein digestibility was also observed with wheat gluten (0.999), though this was not significantly higher than that observed with either blood meal (0.987) or vitamin free casein (0.968). In all cases the digestibility of dietary protein was higher than that of respective dry matter.

Energy digestibilities of each of the diets and ingredients were largely consistent with the observed protein digestibilities (Table A27). An exception to this was wheat flour, which had a significantly poorer energy digestibility (0.340) than its protein digestibility (0.660).

The level of inclusion ( $100 \text{ g kg}^{-1}$  or  $200 \text{ g kg}^{-1}$ ) of meatmeal in a test diet did not significantly influence the digestibility values determined for dry matter, protein or energy (Table A27).

The additive digestibility of compounded diets, as estimated from the individual digestibility values, was not significantly different from that measured for actual compound diets (Table A28). Though the high levels of variance observed in these determinations do not provide much statistical power for these parameters.

The flesh amino acid composition of dhufish (Table A29) was highest in glutamic acid (glutamate) at  $9.37 \text{ g kg}^{-1}$  DM, though the highest likely indispensable amino acid (IAA) was lysine at  $7.43 \text{ g kg}^{-1}$  DM. On a basis proportional to lysine, glutamate was present at 126%, though of the noted IAA, the highest proportion was leucine (70.0%,  $9.37 \text{ g kg}^{-1}$  DM) and the lowest was cysteine (10.5%,  $0.78 \text{ g kg}^{-1}$  DM).

The fatty acid composition (Table A29) of the flesh shows high levels (33.4%) of the long-chained polyunsaturated n-3 fatty acid docosahexaenoate (DHA; 22:6n-3). High levels (7.8%) of the long-chained polyunsaturated n-6 fatty acid arachidonate (ARA; 20:4n-6) were also present. Notable by its absence (0.1%) was eicosapentaenoate (EPA; 20:5n-3).

## Discussion

The development of grow-out diets for new species needs to satisfy several demands. Prospective aquaculturists will require information that will enable them to request the most appropriate diet specifications (primarily dietary protein and energy requirements). However, a feed miller requires information on the nutritive value of a suite of ingredients to be able to provide diets to the specifications requested, and to do so on a cost-effective basis. Ideally the nutritive value assessment should detail the available amino acids and metabolisable energy from specific ingredients (Masumoto *et al.*, 1996; Rodehutsord and Pfeffer, 1999). However, preliminary to this is the assessment of digestible protein and energy levels (van Barneveld, 1999). The present study details the nutritive value of nine ingredients frequently used by feed millers to produce diets. Also presented are the animal's native amino and fatty acid compositions to allow preliminary estimation of possible essential nutrient requirements.

### *Assessment of the nutritive value of key feed ingredients*

In this study the ingredient assessment method of diet substitution was used to determine the digestible dry matter, protein and energy values of a range of ingredients, ingredient inclusion levels and complementary additivity (Nengas *et al.*, 1995; Asknes *et al.*, 1996; Aksnes and Opstvedt, 1998; Allan *et al.*, 1999).

The dry matter digestibilities for all ingredients varied considerably (Table A27). The high levels of digestibility of ingredients such as wheat gluten (0.999), blood meal (0.946) and vitamin free casein (0.892) are consistent with what has been reported for similar ingredients in other species such as silver perch, *Bidyanus bidyanus* (Allan *et al.*, 1999). The lowest dry matter digestibility was observed for wheat flour (0.351) and canola meal (0.387), consistent with limited carbohydrase activity being present in this species.

Protein digestibilities also varied considerably between ingredients (Table A28). Similar to what was observed for the dry matter digestibilities, protein digestibility was also high with wheat gluten (0.999), blood meal (0.987) and vitamin free casein (0.968). The energy digestibility of each of the ingredients was also largely consistent with the observed protein digestibilities (Table A27). An exception to this was wheat flour, which had a significantly poorer energy digestibility (0.340) than its protein digestibility (0.660). This observation is consistent with the low protein content and high carbohydrate content of the wheat flour (Tables A26 and A27). The values observed in this study for protein and energy digestibilities are consistent with what has been reported for similar ingredients in other species, notably those with carnivorous tendencies such as atlantic salmon, *Salmo salar* and rainbow trout, *Oncorhynchus mykiss* (Asknes and Opstvedt, 1998; Storebakken *et al.*, 1998; Sugiura *et al.*, 1998; Allan *et al.*, 1999). The observation of poor utilisation of the wheat flour is consistent with there being limited digestion of carbohydrates with this ingredient. It would be of interest to examine the digestibility of this

ingredient when the starch content of the wheat flour has been gelatinised. In its native form, wheat flour provides limited nutritional value to dhufish.

Generally though, the animal protein meals were not consistently better utilised than the plant protein meals. Plant meals such as soy meal, wheat gluten and canola meal all had protein utilisation values equal to that of any of the animal derived meals. However the actual biological value of these ingredients and the metabolic cost associated with their metabolism remains to be determined. Most appropriate methods to determine this would be by a summit dilution style of experiment as used by Booth *et al.* (1999).

Inclusion of an ingredient at two different levels did not significantly influence the digestibility of that ingredient in any of the assessed parameters of dry matter, protein or energy digestibility. This observation is consistent with what has typically been observed with other species, though it has been noted that the variability of the digestibility determinations decreases with increasing test ingredient inclusion (Smith and Tabrett, 1999). However, in this study it should be noted that the influence of inclusion level was only tested with a single ingredient. This observation would gain further confidence if repeated with at least two further ingredients, with at least two inclusion levels each.

Examination of the additivity of the digestibility parameters determined in this study demonstrated that the digestibility of dry matter, protein and energy values for this species are additive, similar to observations with other species (Allan *et al.*, 2000). However, the high levels of variance observed in some of these determinations reduced the statistical power for these parameters (Searcy-Bernal, 1994). Similar to the determinations of inclusion level on the influence of digestibility, further consolidation of the data would be achieved with examination of both additional compound diets and/or the inclusion of more than two test ingredients in a test compound diet.

#### *Estimation of essential nutrient requirement*

The examination of the amino acid composition of the flesh of wild caught West Australian dhufish show high levels of similarity to the flesh of other teleosts (Kaushik, 1998). Evaluation of the IAA requirements, as based on the principles of Kaushik (1998), also suggests that as with most other fish species, that the first limiting amino acid of dhufish is also likely to be lysine. The second most required is likely to be leucine followed by isoleucine, based on the relative abundance of the amino acid of the flesh, relative to the amount of lysine. Based on these speculated requirements and the now known digestibilities of various protein resources, diets providing adequate amino acids for growth at various energy levels should be able to be formulated. However, what this study does not take into account, that would have added considerable value, is the relative digestibilities of each of the amino acids from each of the feed

ingredients (Masumoto *et al.*, 1996). This would considerably strengthened the value of the digestibility data from a feed millers perspective, allowing even more cost effective development of feeds for this species. It would be worth revisiting the digestible requirements of this species on a nitrogen retention basis to determine the most precise requirements for the IAA (Forster and Ogata, 1998).

Of all the dietary nutrients an animal ingests, none more so that the fatty acids have a direct bearing on the composition of those same nutrients in the animal's own tissues (Sargent *et al.*, 1993). Accordingly, an examination of the animal's native fatty acids may possibly enable a qualitative estimation of it's essential fatty acid requirements. In the flesh of wild-caught dhufish the fatty acids of note were the long-chained polyunsaturated n-3 fatty acids: docosahexaenoate (DHA; 22:6n-3), eicosapentaenoate (EPA; 20:5n-3) and although uncommon at appreciable levels in marine species, the long-chained polyunsaturated n-6 fatty acid arachidonate (ARA; 20:4n-6) was also present at appreciable levels. These three fatty acids have often been identified as essential fatty acids (EFA) in other aquaculture species (Watanabe, 1982).

The levels of tissue EPA were notable by their relative absence (0.1%) compared with that seen in most other aquaculture species and industrial fish oils (Glencross and Smith, 1997). In contrast the levels of DHA were considerably higher (33.4%) than those observed seen in most other aquaculture species and industrial fish oils. Similarly ARA was also present at appreciable levels (7.8%). These observations suggest that this species requirement for EPA may be low, though that requirements for both DHA and ARA possibly exist and that those for DHA may be quite high. Despite these speculations, determination of the EFA requirements would not be suggested as a priority for diet development for dhufish until the dietary protein and energy requirements have been more clearly defined.

#### *Further diet development for this species*

The determination of the dietary protein and energy requirements are suggested as the next crucial phase of diet development for this species. This information would provide valuable details to optimise diets for cost-effective grow-out production of this species. Combined with the ingredient digestibility information, this would also provide the crucial details required by feed millers for cost-effective diet production. However the determination of the protein and energy requirements of this species should be performed on a digestible protein and energy basis to be of most value (Gurure *et al.*, 1995). This process of nutrient requirement evaluation can be determined even more precisely by conducting critical assessment of the animal's requirements for limiting amino acids (primarily lysine as based on data from this study) per unit of metabolisable dietary energy (Kaushik, 1998). Based on the observations of Kaushik (1998) of the higher protein requirements of marine species, such a definitive determination of nutrient requirements may be warranted.

## Acknowledgments

We acknowledge the support of the Fisheries Research and Development Corporation, Project 99/322 : Further development of aquaculture techniques for production of W.A. Dhufish (*Glaucosoma hebraicum*). We also acknowledge the assistance of Ms K. Freeman.

## References

- Aksnes, A., Hjertnes, T. and Opstvedt, J. 1996. Comparison of two assay methods for determination of nutrient and energy digestibility in fish. *Aquaculture*, 140: 343-359.
- Aksnes, A. and Opstvedt, J. 1998. Content of digestible energy in fish feed ingredients determined by the ingredient-substitution method. *Aquaculture*, 161: 45-53.
- Allan, G.L., Rowland, S.J., Parkinson, S., Stone, D.A.J. and Jantrarotai, W. 1999. Nutrient digestibility for silver perch *Bidyanus bidyanus*: development of methods. *Aquaculture*, 170: 131-145.
- Allan, G.L., Parkinson, S., Booth, M.J., Stone, D.A.J. and Jantrarotai, W. 2000. Replacement of fish meal in diets for Australian silver perch *Bidyanus bidyanus*: Digestibility of alternative ingredients. *Aquaculture*, 186: 293-310.
- AOAC (Association of Official Analytical Chemists). 1984. Official Methods of Analysis of the Association of Official Analytical Chemists. 14<sup>th</sup> edition. Association of Official Analytical Chemists. Washington, DC, USA.
- Arnessen, P., Krogdhal, A. and Sundby, A. 1995. Nutrient digestibilities, weight gain and plasma and liver levels of carbohydrates in Atlantic salmon (*Salmo salar*, L.) fed diets containing oats and maize. *Aquaculture Nutrition*, 1: 151-158.
- Austreng, E. 1978. Digestibility determinations in fish using chromic oxide marking and analysis of contents from different segments of the gastrointestinal tract. *Aquaculture*, 13: 265-272.
- Booth, M.J., Allan, G.L. and Stone, D.A.J. 1999. Utilisation of four agricultural ingredients by silver perch. World Aquaculture Society Annual Meeting, Sydney, Australia, 26<sup>th</sup> April – 2<sup>nd</sup> May 1999. pp 83.
- Folch, J. Lees, M. and Sloane-Stanley, G.H. (1957) A simple method for the isolation and purification of total lipids from animal tissues. *Journal of Biological Chemistry*., 226, 497-509.



- Glencross, B. D. and Smith, D.M., (1997) Comparison of triacylglycerols, esterified and free fatty acids as neutral lipid sources in the diet of the prawn, *Penaeus monodon*, Aquaculture, 159: 67-85.
- Gurure, R.M., Moccia, R.D. and Atkinson, J.L. 1995. Optimal protein requirements of young Arctic charr (*Salvelinus alpinus*) fed practical diets. Aquaculture Nutrition, 1: 227-234.
- Halver, J.E. (Ed.) 1989. Fish Nutrition. New York: Academic Press.
- Hanley, F. 1987. The digestibility of foodstuffs and the effects of feeding selectivity on digestibility determinations in tilapia, *Oreochromis niloticus* (L). Aquaculture, 66: 163-179.
- Hillebrand, W.F., Lundell, G.E.F., Bright, H.A. and Hoffman, J.I. 1953. Applied Inorganic Analysis. Wiley, New York, USA.
- Kaushik, S.J. 1998. Whole body amino acid composition of European seabass (*Dicentrarchus labrax*), gilthead seabream (*Sparus aurata*) and turbot (*Psetta maxima*) with an estimation of their IAA requirement profiles. Aquatic Living Resources. 11(5): 355-358.
- Masumoto, T., Ruchimat, T., Ito, Y., Hosokawa, H. and Shimeno, S. 1996. Amino acid availability values for several protein sources for yellowtail (*Seriola quinqueradiata*). Aquaculture, 146: 109-119.
- Nengas, I., Alexis, M.N., Davies, S.J. and Petichakis, G. 1995. Investigation to determine digestibility coefficients of various raw materials in diets for gilthead seabream, *Sparus aurata* L. Aquaculture Research, 26: 185-194.
- Nengas, I., Alexis, M.N. and Davies, S.J. 1999. High inclusion levels of poultry meals and related byproducts in diets for gilthead seabream, *Sparus aurata* L. Aquaculture, 179: 13-23.
- NRC (National Research Council). 1993. Nutrient requirements of fish. National Academy Press. Washington. DC. pp 114.
- Pironet, F.N., Bosc, F.A. and Jenkins, G.I. 1999. Preliminary trials of hormone-induced production of fertilised eggs in the West Australian dhufish (*Glaucosoma hebraicum*, Richardson, 19845). Asian Fisheries Science 12: 119-132.
- Potter, I.C. and Hesp, S.A. 1999. Determination of the biological parameters required for managing the fishery of West Australian dhufish. FRDC Project 96/103. Final report. Murdoch University, Perth Western Australia. pp 48.

- Robaina, L., Moyano, F.J., Izquierdo, M.S., Socorro, J., Vergarra, J.M. and Montero, D. 1997. Corn gluten and meat and bone meals as protein sources in diets for gilthead seabream (*Sparus aurata*): Nutritional and histological implications. *Aquaculture* 157: 347-359.
- Rodehutschord, M. and Pfeffer, E. 1999. Maintenance requirement for digestible energy and efficiency of utilisation of digestible energy for retention in rainbow trout, *Oncorhynchus mykiss*. *Aquaculture*, 179: 95-107.
- Sargent, J.R., Bell, J.G., Bell, M.V., Henderson, R.J. and Tocher, D.R., 1993. The metabolism of phospholipids and polyunsaturated fatty acids in fish. In: B. Callou and P. Vittelo (Eds), *Coastal and Estuarine Studies - Aquaculture: fundamental and applied research.*, American Geophysical Union, Washington, DC, USA, 103-124.
- Searcy-Bernal, R. (1994) Statistical power and aquacultural research. *Aquaculture*, 127, 371-388.
- Smith, D.M. and Tabrett, S.J. 1999. Measurement of nutrient digestibility in penaeid prawns. World Aquaculture Society Annual Meeting, Sydney, Australia, 26<sup>th</sup> April – 2<sup>nd</sup> May 1999. pp 706.
- Storebakken, T., Kvein, I.S., Shearer, K.D., Grisdale-Helland, B., Helland, S.J. and Berge, G.M. 1998. The apparent digestibility of diets containing fishmeal, soybean meal or bacterial meal fed to Atlantic salmon (*Salmo salar*): evaluative of different faecal collection methods. *Aquaculture*, 169: 195-210.
- Sugiura, S.H., Dong, F.M., Rathbone, C.K. and Hardy, R.W. 1998. Apparent protein and mineral availabilities in various feed ingredients for salmonid feeds. *Aquaculture*, 159: 177-202.
- Tacon, A.G.J. 1990. *Standard Methods : For the nutrition and feeding of farmed fish and shrimp.* Argent Laboratories Press. Redmond, Washington, USA.
- Van Barneveld, R.J. 1999. Let's not reinvent the wheel – learning from the terrestrial nutrition sector. World Aquaculture Society Annual Meeting, Sydney, Australia, 26<sup>th</sup> April – 2<sup>nd</sup> May 1999. pp 786.
- Watanabe, T., (1982) Lipid nutrition in fish., *Comparative Biochemistry and Physiology*, 73B: 3-15.

## Tables

Table A25. Formulation, proximate and digestibility specifications of the basal diet

Ingredient	g kg <sup>-1</sup>
Fishmeal – Prime	600
Wheat gluten	100
Wheat flour	200
Fish oil	90
Vitamin premix	6
Chromic oxide	4

Measured Nutrient Content	g kg <sup>-1</sup>
Dry matter	912
Crude protein	481
Crude fat	144
Carbohydrate <sup>1</sup>	197
Ash	90
Gross Energy (MJ kg <sup>-1</sup> ) <sup>2</sup>	20.47

Parameter	ADC
Dry matter digestibility	0.958 ± 0.021
Protein digestibility	0.981 ± 0.009
Energy digestibility	0.982 ± 0.009

<sup>1</sup> Carbohydrate calculated by Dry matter – (Protein + Fat + Ash)

<sup>2</sup> Gross energy calculations based on standard energetic values of protein + fat + carbohydrate (NRC, 1993)

Digestibility values are means ± SEM, n ≥ 3. Other values are means of duplicate determinations

**Table A26: Proximate composition of the ingredients used in the test diets. All parameter values are expressed as g kg<sup>-1</sup> on an as-received basis.**

Ingredient	Dry matter	Protein	Fat	Carbohydrate <sup>1</sup>	Ash	Gross Energy
Fish meal – Prime <sup>a</sup>	924	681	95	0	130	20.15
Fish meal - FAQ <sup>a</sup>	912	638	92	0	180	18.73
Wheat gluten <sup>b</sup>	910	762	8	133	7	20.60
Wheat flour <sup>b</sup>	903	150	13	730	6	15.76
Soy Meal <sup>a</sup>	901	450	13	339	70	17.38
Canola meal <sup>c</sup>	888	438	92	299	60	19.13
Meat meal <sup>a</sup>	854	500	79	0	275	14.84
Blood meal <sup>a</sup>	874	763	55	0	20	20.80
Vitamin Free Casein <sup>d</sup>	940	806	35	0	50	21.26

1 Based on dry matter minus protein, ash and fat content. All values are means of duplicate assay determinations.

<sup>a</sup> Sourced from PIVOT Aquaculture Pty Ltd, Cambridge, TAS, Australia

<sup>b</sup> Sourced from WESTON BioProducts Pty Ltd, Henderson, WA, Australia

<sup>c</sup> Sourced from Davison Canola Mills Pty Ltd, Pinjarra, WA, Australia

<sup>d</sup> Sourced from SIGMA Chemical Company, St Louis, MO, USA

**Table A27. Digestible nutrient contributions of specific ingredients.**

Ingredient	Dry matter	Protein	Energy
Fish meal – Prime	0.848 ± 0.095	0.938 ± 0.029	0.932 ± 0.042
Fish meal - FAQ	0.714 ± 0.317	0.885 ± 0.148	0.876 ± 0.138
Wheat gluten	0.999 ± 0.000	0.999 ± 0.000	0.999 ± 0.000
Wheat flour	0.351 ± 0.042	0.660 ± 0.020	0.340 ± 0.008
Soy Meal	0.694 ± 0.200	0.900 ± 0.006	0.897 ± 0.066
Canola meal	0.387 ± 0.133	0.852 ± 0.027	0.769 ± 0.076
Meat meal	0.510 ± 0.065	0.850 ± 0.047	0.788 ± 0.025
Meat meal (100 g kg <sup>-1</sup> )	0.544 ± 0.144	0.844 ± 0.050	0.805 ± 0.057
Blood meal (100 g kg <sup>-1</sup> )	0.946 ± 0.018	0.987 ± 0.001	0.982 ± 0.001
Vitamin Free Casein	0.892 ± 0.085	0.968 ± 0.034	0.954 ± 0.041

All test ingredients were included in diets at 200 g kg<sup>-1</sup> unless otherwise specified.

All values are means ± SEM. n = 3.

**Table A28. Digestible nutrient contributions from compounded ingredient diets**

Diet	Digestible dry matter	Digestible protein	Digestible Energy
Prime + Flour (10 + 10) - Actual	0.804 ± 0.105	0.947 ± 0.028	0.918 ± 0.047
- Expected	0.886	0.945	0.912
Meatmeal + Casein (10 + 10)	0.783 ± 0.257	0.958 ± 0.074	0.906 ± 0.108
- Expected	0.910	0.966	0.961

All values are means ± SEM. n = 3 (except those of the expected values).

**Table A29. Amino and fatty acid compositions of native dhufish flesh**

Amino acid	g kg <sup>-1</sup> dry matter	% relative to LYS	Fatty acid	% of total fatty acids
Aspartic acid	6.64 ± 0.30	89.4	14:0	2.4 ± 0.56
Glutamic acid	9.37 ± 0.49	126.1	14:1n-7	0.2 ± 0.07
Serine	3.00 ± 0.13	40.4	16:0	19.9 ± 0.60
Histidine*	2.56 ± 0.07	34.5	16:1n-7	3.3 ± 0.55
Glycine	4.55 ± 0.19	61.2	18:0	9.0 ± 0.48
Threonine*	3.22 ± 0.15	43.3	18:1n-7 + n-9	14.3 ± 0.82
Cysteine*	0.78 ± 0.03	10.5	18:2n-6	1.0 ± 0.12
Alanine	3.98 ± 0.03	53.6	18:3n-3	0.3 ± 0.05
Arginine*	3.09 ± 0.13	41.6	20:0	0.1 ± 0.06
Tyrosine*	2.39 ± 0.10	32.2	20:1n-9 + n-	0.8 ± 0.10
Valine*	3.34 ± 0.03	45.0	20:4n-6	7.8 ± 1.09
Methionine*	2.73 ± 0.27	36.7	20:5n-3 (EPA)	0.1 ± 0.05
Phenylalanine*	2.66 ± 0.02	35.8	22:0	2.4 ± 0.15
Isoleucine*	3.55 ± 0.08	47.8	22:1n-9 + n-	0.2 ± 0.07
Leucine*	5.20 ± 0.04	70.0	22:6n-3	33.4 ± 1.80
Lysine*	7.43 ± 0.07	100.0	24:0	1.7 ± 0.14
Proline	2.97 ± 0.10	40.0		
			Saturates <sup>1</sup>	36.6 ± 1.07
			Monounsatur	20.3 ± 1.24
			Polyunsaturat	43.0 ± 2.23
			n-3	33.8 ± 1.75
			n-6	9.2 ± 1.18

<sup>1</sup>Comprises sum of 14:0, 16:0, 18:0, 20:0, 22:0 and 24:0. <sup>2</sup>Comprises sum of 14:1n-7, 16:1n-7, 18:1n-7, 18:1n-9, 20:1n-9, 20:1n-11, 22:1n-9, 22:1n-11, 24:1n-11. <sup>3</sup>Comprises sum of 18:2n-6, 18:3n-3, 18:4n-3, 20:3n-3, 20:3n-6, 20:4n-3, 20:4n-6, 20:5n-3, 22:5n-3, 22:6n-3. Comprises sum of 18:3n-3, 18:4n-3, 20:3n-3, 20:4n-3, 20:5n-3, 22:5n-3, 22:6n-3; Comprises sum of 18:2n-6, 20:2n-6, 20:3n-6, 20:4n-6. \* speculated indispensable amino acids

## **Appendix R      *Treatments for ectoparasites and diseases in captive Western Australian dhufish***

Pironet, F.N. & Jones, J.B. 2000: Treatments for ectoparasites and diseases in captive Western Australian dhufish. *Aquacult. int.* 8(4): 349-361

### **Disclaimer**

The importation, purchase and use of chemicals to treat animals (including fish) in Australia is controlled through the National Registration Authority for Agriculture and Veterinary Chemicals. Information on chemicals and dosage rates are provided in this document, based on published data, for specific life stages of individual species under laboratory conditions. The provision of the chemical and dose rate information in this document does not infer that the chemicals may be legally used for aquaculture in Australia. Some of the stated products in this text are unregistered, or not registered for the particular use. This should not be interpreted as a recommendation for use and the authors of this publication take no responsibility for losses should these chemicals or dosages be used in aquaculture. It is an offence to import and supply unregistered chemicals and the supply must be authorised by either a veterinary prescription or permit. Farmers should check the current registration status of chemicals with the National Registration Authority (02 6272 5158, or <http://www.nra.gov.au>)

### **Abstract.**

The Western Australian dhufish (*Glaucosoma hebraicum*), an open-water marine finfish, has been identified as a potential species for aquaculture and a 4 year research project has concentrated on broodstock collection and maintenance, spawning and larval rearing. This paper describes treatments that were developed for the ectoparasites and diseases of broodstock fish. These included bacterial and fungal infections *Cryptocaryon irritans*, *Haliotrema* sp., an unidentified axinid monogenean, the isopod *Aega cyclops* and copepod *Caligus* sp. Treatments based on betadine, formalin, freshwater, malachite green, oxytetracycline (terramycin), 2-phenoxyethanol, potassium permanganate and trichlorphon (neguvon) were all tried. The most effective treatments against parasites were a freshwater bath or a combined freshwater bath and anaesthesia with 2-phendxyethanol. Monogeneans on the gills were difficult to control and exophthalmia was an unresolved problem.

### **Introduction**

The Western Australian dhufish (*Glaucosoma hebraicum*) (Family Glaucosomatidae), is found in Western Australian waters between Beagle Island (21° 12'S, 115° 30'E) in the Dampier Archipelago in the north, and the Recherche Archipelago (33° 52'S, 121° 54'E) to the south at depths from 10 to -200 m. Highly prized as a game and food fish in coastal areas, this species attains a maximum size of 1.2 m TL and 26 kg (Kailola *et al.*, 1993; McKay, 1997).

Preliminary estimates were that dhufish grow to about 30 cm TL after 1 y and 40-45 cm TL after 2 y (Kailola *et al.*, 1993). Because of its growth potential, the availability of broodstock locally and its high value as a food fish, the dhufish was selected by the Fremantle Maritime Centre (Western Australia) for a research project to establish a breeding protocol in captivity and to assess the viability of this species in aquaculture (Pironet and Neira, 1998).

Dhufish have not previously been bred in captivity and there are no published accounts of diseases and treatments in captive fish. The difficulties encountered in catching and keeping broodstock ensured that each live fish was very valuable which, together with ethical considerations, required that sick fish be treated and restored to health when practicable. Neither the broodstock fish nor their progeny were intended for human consumption and therefore the use of unregistered drug treatments was permissible. This paper describes the treatments which were applied to control the ectoparasitic fauna and diseases observed in captive dhufish broodstock during the first 2 y of the research project.

## Materials and methods

### *Capture of broodstock fish*

A total of 82 dhufish were captured between 1995 and 1997 by hand-line off Ledge Point (31° 7'S, 115° 22'E) in depths of <25 m. Fish caught from waters deeper than 25 m seldom survive due to the effects of decompression (Ashby, unpublished thesis results, University of Western Australia). Upon capture the swim bladder was vented with a sterile 16 gauge hypodermic needle before transport to the Fremantle Maritime Centre in a 900 L aerated tank. On arrival, fish were anaesthetised in 2-phenoxyethanol (approximately 300 mg.L<sup>-1</sup>) and treated to remove external parasites as described below.

Fish were kept in enclosed tanks of 10~50 m<sup>3</sup> capacity, with continuously flowing sand-filtered seawater at a minimum of 10% renewal per hour. Holding tanks were partly covered with black plastic to reduce light intensity. The size of captured fish varied from 1.6 to 12 kg and fish biomass ranged from 0.5 to 3.0 kg/m<sup>3</sup>.

### *Treatments (against skin and gill parasites)*

All treatments are summarised in Table A30. Details on some of them are described below.

#### Phenoxyethanol and freshwater

Fish were sedated in approximately 300 mg.L<sup>-1</sup> 2-phenoxyethanol, transferred into a 600 L container of freshwater and left for 1.5 h with pure oxygen aeration. Fish were released directly into the holding tank on completion of the treatment. Freshwater used in treatments was potable tap water from the municipal supply (a variable mixture of catchment and bore hole water chemically treated to comply with health standards).

#### Freshwater

Captive fish requiring treatment were starved for 24 h to avoid induction of vomiting (a common stress reaction in dhufish). Water salinity was lowered to  $\leq 1\lambda$  within 1-2 h, maintained at this concentration for 1.5 h, then rapidly raised back to full strength (35  $\lambda$ ). Salinity was measured



with a prism refractometer (0-10  $\lambda$ ). The temperature difference between the fresh water used in the treatment and the ambient seawater in the tank was not allowed to exceed 2 °C since sudden changes in temperature can be lethal to marine fish (Wedemeyer *et al.*, 1976). Tanks were successively treated in order to achieve three consecutive treatments per tank at 10 day intervals in September-October (Austral spring) while seawater temperature was -19°C and rising (annual range 15-26 °C). The course of treatments was completed at least 1 month before the beginning of the spawning season (November to April). If mortality of fish occurred at the beginning of a treatment course, freshwater and 2-phenoxyethanol were used in the subsequent treatments.

#### Freshwater and antibiotic

During the first and tenth day of the treatment course, salinity was lowered to  $<1\lambda$  within 1 h. Terramycin (10% oxytetracycline active ingredient) was added to reach a final concentration of 300 mg.L<sup>-1</sup> terramycin and the bath treatment lasted for 1.5 h after which salinity was restored to 35‰ by rapid flushing. During the following 8 days, terramycin was administered orally (0.5 g terramycin kg-L body weight). Non-feeding fish were treated instead with a terramycin bath at 300 mg.L<sup>-1</sup> concentration (as above).

#### Formalin and malachite green

Fish were treated by lowering salinity to 17‰ then adding formalin and malachite green to reach final concentrations of 75 and 0.24 mg.L<sup>-1</sup> respectively. Treatment continued for 2.5 h. Treatment was performed at a water level 10 cm above normal level to ensure that the tank "splash zone" was treated. After 2.2 h the water level was lowered to half volume and treatment ended with rapid flushing of the tank with full-strength seawater for 20 min.

#### Betadine (povidone-iodine) and 2-phenoxyethanol

Fish were anaesthetized in 300 mg.L<sup>-1</sup> 2-phenoxyethanol for 10-15 min. Lesions were swabbed with Betadine (iodine 1% w/w) and allowed to dry for 10 s before the fish were returned to seawater.

#### *Identification of parasites*

Samples of tissue for histology were fixed in 10% seawater buffered formalin, dehydrated in an alcohol series, embedded in wax and stained with haematoxylin and eosin using standard laboratory techniques. Helminths were fixed in Berland's fluid (19 parts pure glacial acetic acid + 1 part formalin) and stored in 70% alcohol. Crustaceans were fixed in 10% seawater buffered formalin and stored in 70% alcohol prior to identification. If bacterial infection was suspected blood and tissue samples were submitted to the Agriculture WA Animal Health Laboratories for bacterial culture. Voucher specimens of the isopod, copepod and monogenean parasites have been deposited at the Western Australian Museum.

**Table A30: Treatments used, their duration and survival rate of dhufish in captivity at Fremantle**

Treatment	Number of fish	Concentration used	Duration of treatment	Survival (%)	Results
2-phenoxyethanol and freshwater	115	300mg.l <sup>-1</sup> 2-phenoxyethanol	1.5h	100	Effective against isopods, copepods and monogeneans. Not tolerated by spawning fish
Freshwater only	82	<1λ salinity	Salinity lowered over 1-2h, maintained 1.5h	91.5	Effective against isopods, copepods and monogeneans. Not tolerated by spawning fish
Freshwater and terramycin	6	<1λ water 300mg.l <sup>-1</sup> terramycin	Lowered over 1-2h, maintained 1.5h, repeated day 1 and 10	100	Effective in treating monogeneans and concurrent bacterial infections on gills. See text for details.
Formalin and malachite green	24	Salinity 17λ Formalin 75 mg.l <sup>-1</sup> Malachite green 0.24 mg.l <sup>-1</sup>	2.2h	91.7	Effective in treating <i>Cryptocaryon</i> Partially effective against monogeneans Cannot be used on spawning fish
Betadine + 2 phenoxyethanol	8	300mg.l <sup>-1</sup> phenoxyethanol betadine swab	Not applicable	100	Very effective on superficial fungal infections
Formalin bath	4	150mg.l <sup>-1</sup>	1.0h	100	Ineffective on monogeneans
Neguvon*	15	1.1 mg.l <sup>-1</sup>	5.0h	100	Ineffective on monogeneans
	4	1.25 mg.l <sup>-1</sup>	15h	50	Partially effective on monogeneans
Potassium permanganate	6	4.2 mg.l <sup>-1</sup>	1.0h	0	Lethal to fish

## Results

### *Survival after treatments*

Results are shown in Table A30. Once the methodology associated with capture and transport of fish was established, including venting, survival was 95%. Newly captured broodstock fish treated with 2-phenoxyethanol and freshwater had 100% survival, though food vomiting was frequent in wild-caught fish. During a freshwater ( $\leq 1$  ‰ salinity) treatment fish typically remained motionless on the bottom of the container, often lying on their side. A violent swimming reaction preceded death of the fish concerned if its removal from the bath was not immediate.

### *Ectoparasites and diseases*

#### Bacteria

Bacterial infection appeared as one or several yellow or white-coloured focal gill lesions of up to 1 cm<sup>2</sup> in area on 11/82 fish and on two occasions affected approximately 50% of the visible gill area. In six of the eleven cases, these bacteria were identified from blood samples as *Vibrio parahaemolyticus* (dominant species) of concurrent *V. parahaemolyticus* and *V. alginolyticus*. At different times, from three moribund fish without gill lesions uncharacterised *Photobacterium* spp., *P. damsela damsela*, or *V. fluvialis* with unidentified *Vibrio* spp. were isolated from kidney and spleen.

#### Fungi

Two types of lesions were observed in 8/82 fish, both lesions were associated with the presence of unidentified septate fungal hyphae: a white-coloured lesion on the dorsal surface or caudal peduncle of the fish and a reddish, non-haemorrhagic, calloused abrasion caused by rubbing on the bottom of the tank. A single treatment using 2-phenoxyethanol and Betadine, carried out 2 weeks from first observance of this condition, induced rapid healing of both types of lesion.

#### Cryptocaryon irritans BROWN, 1951

In August 1996, all six fish in one tank began feeding as normal on day 2 after capture but stopped feeding on day 8. Within 2 weeks vertical stripe like lesions appeared on the flanks of the fish. Lesions were haemorrhagic and oedematous, with scales lifting and shedding. Pyriform anteriorly-pointed theronts and ovoid trophonts were identified as those of *C. irritans* in skin scrapes. Secondary bacterial infections consisting mainly of *Vibrio* spp and unidentified gram-negative rods were isolated from lesions. One week from first observation of lesions, one fish died. Treatment of the five surviving fish with formalin and malachite green was carried out and repeated twice at 5 day intervals. Lesions healed slowly and disappeared within 3 weeks.

### Haliotrema sp.

Flukes of an undescribed species of *Haliotrema* were frequently observed attached to the gills and to the skin over the whole body surface of the dhufish. Flukes measured 50-1100  $\mu\text{m}$  (753 [ $\pm 116$ ]  $\mu\text{m}$  SD, n = 30) length *in vivo*. Affected fish rubbed with brief tail flicks on the tank bottom or piping. Fish did not appear to be affected by this parasite during the winter period but in September, as the incoming seawater temperature increased to 18°C, they began to display the signs of infection. Examination of skin scrapes confirmed the nature of the parasite. These flukes seemed sensitive to 2-phenoxyethanol, as after 10 min. in approximately 300 mg.L<sup>-1</sup> concentration 2phenoxyethanol, the majority of the flukes tended to lose grip of their host.

### Monogenea: Axininae

A monogenean belonging to the subfamily Axininae was typically observed in low numbers on gills of wild caught dhufish. Flukes multiplied on gills of fish maintained under stressful conditions such as high water temperatures (above 25°C), poor water quality, exophthalmia or overcrowding. Infested fish were dark in colour, displayed frequent opercular movements; dysnopea and mucous production were evident. All freshwater based treatments provided effective control.

### Aega cyclops HASWELL, 1881

These isopods were commonly observed on wild fish and typically emerged from the fish nostrils during the freshwater treatment following post-capture anaesthesia.

### Caligus sp.

An undescribed species of *Caligus* was commonly observed on wild fish, clinging on the skin over the head area and particularly the cornea of the eyes. These copepods were associated with ulceration and haemorrhage in untreated fish. They were killed by freshwater treatments.

### *Non-infectious conditions*

#### Exophthalmia

Unilateral or bilateral exophthalmia occurred in 70 and 20% of the broodstock during the first and second year of study respectively and was also observed in dhufish as young as 5.5 months old. Exophthalmia was initially unilateral, the affected eye was haemorrhagic, swollen and in extreme cases the cornea ruptured. Fish ceased feeding and remained stationary near the bottom of the tank with minimal fin movement. In the worst cases, the fish developed a head-down swimming posture and the unaffected eye often developed mild exophthalmia. No parasite was observed in association with dhufish exophthalmia and, in most cases, no bacteria were isolated from

affected fish eyes. In many cases, but not all, exophthalmia in dhufish was observed within 24 h of a violent impact with a hard surface, self-inflicted during a struggle or scare. Following these observations strict preventive measures were taken to limit self-inflicted damage to the eyes and, as a result, the rate of occurrence of exophthalmia decreased but was not eliminated. Gross examination of affected eyes at necropsy, confirmed by histology, showed that the exophthalmic condition was due to retrobulbar accumulation of blood from haemorrhage of blood vessels in the choroidal rete. No effective treatment was found but in the majority of cases, fishes recovered naturally after several weeks and deep tanks (23 m depth) were more effective in aiding recovery. In severe cases, the damaged eyeball was excised under anaesthesia, which resulted in full recovery of the fish within several days.

## Discussion

Dhufish appeared to adapt reasonably well to captivity and the breeding programme met with some success (Pironet and Neira, 1998). Of the ectoparasites and diseases encountered during the project, only the monogeneans and exophthalmia caused persistent concern.

Gill monogeneans are common parasites of marine fish in captivity and can be difficult to control, especially in warm water systems. As a result, there are a large number of attempted treatments in the literature (Cone, 1996). In this study, both fluke species were effectively controlled with freshwater ( $\leq 1\%$  salinity) or with a combination of 2-phenoxyethanol and freshwater baths. It is interesting that a freshwater treatment is tolerated by a large marine fish that normally has no exposure to estuarine or freshwater conditions.

Freshwater baths for up to 5 h have been proved effective at controlling monogeneans in marine fish (Kabata, 1985; Seng and Seng, 1992). However, the safety and efficacy of this type of treatment need to be evaluated for each species (Kaneko *et al.*, 1988). Preliminary observations suggested that recently caught dhufish may be more tolerant to low salinity than fish which have spent some time in captivity, and that juveniles less than one year old may not survive freshwater baths (data not presented).

Combined treatment with formalin and malachite green has been extensively used in aquaculture for the treatment or prevention of fungal and parasitic infections in fish since at least the 1930's. Malachite green is also an effective systemic anti-protozoal agent (Alderman, 1985; Clifton-Hadley and Alderman, 1987; Plakas *et al.*, 1996). Malachite green is still used with ornamental fish in Australia, but is a suspected carcinogen and demonstrated teratogen (Meyer and Jorgenson, 1983), and is not registered for use with food fish. The legal status of most commonly used chemicals in aquaculture, including malachite green, is under review in many countries and there is not yet any international consensus over its use (Schnick *et al.*, 1997). The use of malachite green, in particular, has been severely restricted for food fish use in the USA and in the European Union but continues to be used elsewhere. Malachite green has been used mainly in cold water salmonid culture. Toxicity and effectiveness varies both with

temperature and dye batches, so that Alderman (1985) warned that published "safe dosages" should be regarded with caution. In this study, which deals with a warm water species, the dosage used was not lethal to the fish and was effective against *Cryptocaryon irritans*. However, since *C. irritans* is sensitive to low salinity and undergoes cytolysis at salinities below 20‰ (Colomi, 1985), a freshwater bath may have been just as effective in achieving control. Trials to assess the effect of freshwater treatment on local strains of *C. irritans* remain to be carried out.

Formalin at 15~200 mg.L<sup>-1</sup> for 26 h has been used successfully in marine systems against many parasites, including monogeneans (Kabata, 1985), but it was ineffective at treating dhufish gill parasites at the dose rates used. Marine monogeneans can also be controlled by 50 mg.L<sup>-1</sup> Dipferex (Neguvon) for 4-5 min followed 7 d later by 30 mg.L<sup>-1</sup> for 8-16 min. (Kabata, 1985). Varriale *et al.* (1992) found Neguvon effective at removing *Diplectanum aequans* from sea bass (*Dicentrarchus labrax*) in brackish water at concentrations as low as 0.15 mg.L<sup>-1</sup> but with minimum exposure times of 48 h. In dhufish, a dose rate of 1.25 mg.L<sup>-1</sup> Neguvon for 15 h was lethal to the host and only partially effective at removing monogeneans. Potassium permanganate is a popular treatment for monogeneans (Kabata, 1985), usually in freshwater hosts, either at 2 mg.L<sup>-1</sup> for an indefinite bath or 3-5 mg.L<sup>-1</sup> for a single application (Allison, 1957; Kabata, 1985). It was toxic to dhufish in seawater, at a concentration within the recommended range for freshwater use. Toxicity is known to vary widely between species (Wellborn, 1969; van Duijn, 1972). For example, 3 mg.L<sup>-1</sup> has proved to be toxic to striped bass (*Morone saxatilis*) fingerlings in freshwater and at 1.48 mg.L<sup>-1</sup> in salinities of 15‰ (Reardon and Harrell, 1994).

A large number of treatments have been recommended against fungal infections. Among these, an indefinite bath of 2-phenoxyethanol at 100 mg.L<sup>-1</sup> has been successfully used to treat fungus-infected fish (Kabata, 1985, van Duijn, 1972). It is likely that the use of 2-phenoxyethanol as a general anaesthetic at the Fremantle Maritime Centre has kept down the incidence of fungal infections. Betadine, as with other iodine-based disinfectants, is commonly used to disinfect fish eggs, but may also be used as a replacement for the tincture of iodine (at 1.0-50‰) which van Duijn (1972) and Kabata (1985) used successfully to remove fungal lesions from fishes.

Eye disorders such as cataracts and exophthalmia are common diseases amongst fishes maintained in captivity. Eye damage in fish, and exophthalmia in particular, can be caused by bacteria, viruses, parasites as well as by nutritional, temperature and hormonal imbalances or malformations (Dukes, 1975; Blasiola, 1987; Bucke, 1998; Bjerkas and Bjornestad, 1999). In many cases, the cause of exophthalmia remains unknown (Chawadhary *et al.*, 1978). Diet is unlikely to be responsible for the disease in dhufish since it was balanced and consisted of frozen fish, squid and prawn supplemented with a stable vitamin mix. Gas-bubble disease is widely reported as a causative agent of exophthalmia in finfish (Dukes, 1975; Kulshrestha and Mandal, 1982; Hauck, 1986; Machado *et al.*, 1987), but was not a cause of exophthalmia in dhufish since the water supply to the tanks was de-saturated by passage through degassing

columns and was monitored for supersaturation. It is hypothesised that the exophthalmia is due to malfunction of the oxygen secretion mechanism within the rete mirabile and pseudobranch (Dehadrai, 1966).

### **Conclusions and recommendations**

The experimental aquaculture of dhufish has provided an opportunity to develop specific treatment protocols for common conditions affecting this offshore marine fish. Despite the lack of exposure to low salinity under normal conditions, the fish has proved remarkably tolerant to freshwater treatments and these are now routinely used at Fremantle. The major fish health problem still facing culture is the propensity of the fish to develop exophthalmia. Further work to determine the aetiopathogenesis of the lesion is currently being carried out.

### **Acknowledgments**

We wish to thank the South Metropolitan College of TAFE and the staff at the Fremantle Maritime Centre for their assistance and support during the project. Franz and Mary Van Der Poll helped in collecting the broodstock fish and Dr D Kritsky (Idaho State University) who identified the *Haliotrema* sp. Dr Greg Maguire and two anonymous referees provided valuable editorial comment. This research was funded by the South Metropolitan College of TAFE and the Fisheries Research and Development Corporation (Projects 95/095 and 96/308).

### **References**

- Alderman, DJ. (1985) Malachite green: a review. *Journal of Fish Diseases* 8, 289-298.
- Allison, R. (1957) Some new results in the treatment of ponds to control some external parasites of fish. *The Progressive Fish Culturist* 19, 58-63.
- Blasiola, G.C. (1987) Ophthalmic disease of fishes. *Freshwater and Marine Aquarium* 10(7), 4~50.
- Bjerkas, E., and Bjørnstad, E. (1999) Is there a connection between rapid fluctuation in water temperature and cataract development in the Atlantic salmon (*Salmo salar*). *Bulletin of the European Association of Fish Pathologists* 19, 16~169.
- Bucke, D. (1998) Cataracts in farmed fish - a multidisciplinary initiative for scientific progress: histological techniques for teleost eyes. *Bulletin of the European Association of Fish Pathologists* 18, 121-123.
- Chawadhary, S.K., Srivastava, J.B. and Shamra, J.P. (1978) Occurrence of exophthalmus in murrel (*Ophiocephalus punctatus*). *Indian Journal of Animal Research* 12, 51-52.

- Clifton-Hadley, R.S. and Alderman, D.J. (1987) The effects of malachite green on proliferative kidney disease. *Journal of Fish Diseases* 10, 101-107.
- Colomi, A. (1985) Aspects of the biology of *Cryptocaryon irritans* and hypersalinity as a control measure in cultured gilthead sea bream *Sparus aurata*. *Diseases of Aquatic Organisms* 1, 19-22.
- Cone, D.K. (1996) Monogenea (Phylum Platyhelminthes). In: PTK. Woo (ed.), *Fish Diseases and Disorders, Vol I. Protozoan and metazoan infections*. CAB International. pp. 289-389.
- Dehadrai, P.V. (1966) Mechanism of gaseous exophthalmia in the Atlantic cod *Gadus morhua* L. *Journal of the Fisheries Research Board of Canada* 23, 909-914.
- Dukes, T.W. (1975) Ophthalmic pathology of fishes. In: WE. Ribelin and G. Migaki (eds.), *The Pathology of Fishes*. University of Wisconsin Press, Wisconsin, pp. 383-398.
- Hauck, A.K. (1986) Gas bubble disease due to helicopter transport of young pink salmon. *Transactions of the American Fisheries Society* 115, 630-635.
- Kabata, Z. (1985) *Parasites and Diseases of Fish Cultured in the Tropics*. Taylor and Francis, London, 318 pp.
- Kailola, P.J., Williams, M.J., Stewart, P.C., Reichelt, R.E., McNee, A. and Grieve, C. (1993) *Australian Fisheries Resources*. Bureau of Resource Sciences, Canberra, 422 pp.
- Kaneko, J.J., Yamada, R., Brock, J.A. and Nakamura, R.M. (1988) Infection of tilapia, *Oreochromis mossambicus* (Trewavas), by a marine monogenean, *Neobenedenia melleni* (MacCallum, 1927) Yamafuti, 1983 in Kaneohe Bay, Hawaii, USA, and its treatment. *Journal of Fish Diseases* 11, 295-300.
- Kulshrestha, A.K. and Mandal, P.K. (1982) Pathology of gas bubble disease in two airbreathing catfishes (*Clarias batrachus* Linn. and *Hereropneustes fossilis* Bloch.). *Aquaculture* 27, 13-17.
- Machado, J.P., Garling, J., Keven, N.R., Trapp, A.L. and Bell, G. (1987) Histopathology and the pathogenesis of embolism (gas bubble disease) in rainbow trout (*Salmo gairdneri*). *Canadian Journal of Fisheries and Aquatic Sciences* 44, 1985-1994.
- McKay, R.J. (1997) *FAO Species Catalogue Volume 17: Pearl fishes of the world (Family Glaucosomatidae)*. *FAO Fisheries Synopsis* 125/17, 28 pp.
- Meyer, E.P., Jorgenson, T.A. (1983) Teratological and other effects of malachite green on development of rainbow trout and rabbits. *Transactions of the American Fisheries Society* 112, 818-824.



- Pironet EN. and Neira, F.J. (1998) Hormone-induced spawning and development of artificially reared larvae of the Western Australian Dhufish, *Glaucosoma hebraicum* (Pisces: Glaucosomatidae). *Marine and Freshwater Research* 49, 133-142.
- Plakas, S.M., El Said, K.R., Stehly, G.R., Gingerich, W.H. and Allen, J.L. (1996) Uptake, tissue distribution and metabolism of malachite green in the channel catfish (*Ictalurus punctatus*). *Canadian Journal of Fisheries and Aquatic Science* 53, 1427-1433.
- Reardon, I.S. and Harrell, R.M. (1994) Effects of varying salinities on the toxicity of potassium permanganate to larval and juvenile striped bass, *Morone saxatilis* (Walbaum). *Aquaculture and Fisheries Management* 25, 571-578.
- Schnick, R.A., Alderman, D.J., Armstrong, R., Le Gouvetlo, R., Ishihara, S., Lacierda, S., Percival, S. and Roth, M. (1997) World wide aquaculture drug and vaccine registration progress. *Bulletin of the European Association of Fish Pathologists* 17, 251-260.
- Seng, L.K. and Seng, L.T. (1992) Treatment of cultured golden snapper *Lutjanus johni* Bloch, infected with monogeneans. *Aquaculture* 106, 1-8.
- Varriale, A.M.C., Cecchini, S. and Saroglia, M. (1992) Therapeutic trials against the *Diplectanum aequans* (Monogenea), parasite of sea bass (*Dicentrarchus labrax* L.) in intensive farming. *Bulletin of the European Association of Fish Pathologists* 12, 204-206.
- Van Duijn, C. Jnr. (1972) *Diseases of Fishes*, 3rd edition. Iliffe Books, London, 309 pp.
- Wedemeyer, G.A., Meyer, EP., and Smith, L. (1976) *Diseases of Fishes*, Book 5: Environmental Stress and Fish Diseases. T.F.H. Neptune City, NJ, 192 pp.
- Wellborn, T.L. Jr. (1969) The toxicity of nine therapeutic and herbicidal compounds to striped bass. *Progressive Fish Culturist* 31, 27-32.

## **Appendix S            Intellectual Property**

There are no intellectual property issues regarding this project.

## **Appendix T            Staff**

<b>Personnel</b>	<b>Position</b>	<b>% of time</b>	<b>Period of involvement</b>
Dr Jennifer Cleary	Principal Investigator (ADU)	100	Jan 1998-Aug 2000
Ms Francois Pironet	Principal Investigator (ADU)	100	Jul 1996-Dec 1997
Mr Greg Jenkins	Project Manager (ADU)	10	Jul 1996-Aug 2000
Mr Francois Bosc	Research Biologist (ADU)	100	Jul 1996-Aug 1997
Mr Anthony Aris	Dhufish Technician (ADU)	100	Jan 1999-Aug 2000
Mr Andrew Hughes	Dhufish Technician (ADU)	100	Jul 1997-Jan 1999
Mr Andrew Hughes	Technician (ADU)	5	Jan 1999-Aug 2000
Mr Gavin Partridge	Research Biologist (ADU)	20	Jun 1998-Aug 2000
Mr Ken Frankish	Hatchery Manager (ADU)	10	Jul 1996-Aug 2000
Mr Bruce Ginbey	Assistant Hatchery Manager (ADU)	5	Jul 1996-Aug 2000
Mr Aaron Strawbridge	Technician (ADU)	5	Jul 1996-Aug 2000
Mr Craig Poller	Technician (ADU)	5	Jul 1996-Aug 2000
Mr Dean Kennerly	Technician (ADU)	5	Jul 1996-Aug 2000
Mr James Garde	Technician (ADU)	5	Jul 1996-May 1999
Dr Brian Jones	Fish Pathologist (FWA)	5	Jul 1996-Aug 2000
Dr Sagiv Kolkovski	Research Scientist (FWA)	5	Jul 1999-Aug 2000
Dr Greg Maguire	Research Supervisor (FWA)	5	Jul 1999-Aug 2000
Dr Brett Glencross	Research Scientist (FWA)	5	Jul 1999-Aug 2000
Mr John Curnow	Technician (FWA)	5	Jul 1999-Aug 2000